

Received 5 June 2023, accepted 21 July 2023, date of publication 28 July 2023, date of current version 4 August 2023.

Digital Object Identifier 10.1109/ACCESS.2023.3299825

RESEARCH ARTICLE

A Unified Metering System Deployed for Water and Energy Monitoring in Smart City

N. SUSHMA¹, H. N. SURESH², J. MOHANA LAKSHMI³, (Senior Member, IEEE),
PARVATHANENI NAGA SRINIVASU⁴, AKASH KUMAR BHOI^{5,6,7}, (Member, IEEE),
AND PAOLO BARSOCCHI⁷

¹Department of Electronics and Communication Engineering, Malnad College of Engineering, Hassan 573202, India

²Department of Electrical and Electronics Engineering, Malnad College of Engineering, Hassan 573202, India

³Department of Computer Science and Engineering, Malnad College of Engineering, Hassan 573202, India

⁴Department of Computer Science and Engineering, Prasad V. Potluri Siddhartha Institute of Technology, Vijayawada 520007, India

⁵KIET Group of Institutions, Ghaziabad 201206, India

⁶Directorate of Research, Sikkim Manipal University, Gangtok, Sikkim 737102, India

⁷Institute of Information Science and Technologies, National Research Council, 56124 Pisa, Italy

Corresponding authors: Akash Kumar Bhoi (akashkrbhoi@gmail.com) and Paolo Barsocchi (paolo.barsocchi@isti.cnr.it)

ABSTRACT In the context of smart cities in India, accurate meter readings are crucial for managing household water and energy systems efficiently. However, traditional meter reading methods are costly and time-consuming due to the large number of users and the lack of daily usage analysis leading to customer dissatisfaction. The proposed solution to tackle this matter involves implementing an integrated wireless smart energy and water metering system that utilizes smart metering technology. This system can potentially revolutionize how utilities handle energy and water management. The integrated system is designed to replace the mechanical water meters and conventional digital energy meters, whose primary function is to accurately record meter readings for payment purposes, for automatic meter readings that do not require frequent trips to the location where the meters are installed. This article proposes a smart, integrated wireless metering system to revolutionize customer engagement and energy and water utility management. This technology enables the transmission of precise and secure data on water and energy consumption in real-time by employing Low Power Wide Area Networks (LPWAN) technology, known for its low power consumption, cost-effectiveness, long-range coverage, and efficient penetration. The system has a water flow sensor and PZEM-004T for real-time water and energy consumption readings. The interoperable features in the integrated water flow and energy meter are achieved through trial-and-error methods. The trials led to experimental findings that enabled successful communication between the energy and water flow meters and recorded accurate readings. The device provides the utility provider with real-time consumption statistics and the flexibility to turn on and off the system remotely. The system also helps the users by giving them real-time consumption data and preventing overloading situations. The device also notifies the utility company of the theft of electricity. The proposed system overcomes the gaps reported in the traditional systems and design challenges.

INDEX TERMS LoRa, PZEM-004T, Raspberry Pi Pico, smart energy meter, smart water meter.

I. INTRODUCTION

Cities emphasize becoming smart cities to deal with the growing population, hyper-urbanization, and globalization and assure financial and ecological stability. The idea of a “smart

The associate editor coordinating the review of this manuscript and approving it for publication was Mohammad Ayoub Khan¹.

city” is to use technology and networked data sensors to improve and strengthen city operations and infrastructure [1]. It includes smart water management and smart energy management [2]. The United Nations estimates that during the 1980s, global water use increased by around 1% per year and that by 2050, it will have increased by up to 30% [3]. According to predictions, demand will mostly grow due to

demand in the residential and industrial sectors. Water loss in the supply systems, which on a worldwide scale may reach an incredible quantity of almost 50%, is among the most critical factors affecting the effectiveness of water distribution. They frequently originate from deteriorating infrastructure, inadequate billing procedures, unreliable metering, and illegal use [4], [5]. According to research by the International Renewable Energy Agency [6], by the year 2050, there will be a 50% rise in the demand for water and energy. Yet, there is a significant link between water and energy consumption. As a result, the “water-energy nexus” is just where coordinated research may bring novel ways to resource conservation.

Humans use water for various domestic and industrial uses, such as agriculture, personal hygiene, cleanliness, and other activities that entail energy use. Water, a critical resource for a country’s growth, must be handled wisely to protect it and save energy, money, and the environment [7]. It has led to recognizing of the water-energy nexus as a thorough idea to improve management strategies in the energy and water sectors [8]. Therefore, in this scenario, both the scientific community and the community are paying more attention to the interconnectedness of these two crucial resources. Over time, society has become more adept at jointly managing water and energy resources. Energy and water are reliant on each other for survival. The interdependence of water and energy is centered on several key issues, including water infrastructure, water management systems, sustainable energy, and efficient systems. Collecting information on residential usage habits is critical to propose measures for conserving water and energy.

Traditionally, meters are fixed on the consumer’s residence to collect the energy and water consumed data and are displayed either using the dial meter or a digital display. Meter readers record usage data during their weekly or monthly site visits. There are various drawbacks to this approach. When meters are situated inside a user’s residence, the meter reader may be unable to read and record monthly energy usage if the user is not home [9]. In these cases, the utility company must use the average monthly bill amount to guide consumption. Electricity use and billing estimates are unfair to the corporation and the customer. The consumer may experience further financial difficulty or complain about the situation if power is not used. This billing approach is inappropriate from the provider’s perspective since it will present an erroneous picture of the total power use in the consumer’s region and might lead to mistakes in the company’s future planning. The traditional method also requires frequent visits to the customer’s premises; hence the utility company hires meter readers at large [10].

The conventional approach of daily data collecting and analysis is time-consuming, and there is a strong likelihood that human mistakes will result in inaccurate data. As a result, manually collecting the data is impractical, particularly in nations with dense populations [11]. It is, therefore, necessary to have an automated system that can monitor usage, alert users to any anomalies, and provide statistics in real-time. Thanks to significant technological improvement, it is

now feasible to monitor and obtain consumption statistics and evaluate them [12]. Smart meters are water and energy consumption monitoring devices that help to reduce use and costs. They are built to record and display real-time usage data. With the use of offer, utility companies and customers may communicate in real-time, which has several advantages for everyone involved. However, it is quite difficult to suggest a smart meter only to track energy and water consumption in a nation like India, where most of the rural population has trouble paying their electricity bills [13]. So that it doesn’t become a burden for customers and the utility company, a balance is needed in terms of cost between selecting the appropriate communication infrastructure, designing a smart meter, and replacing the present meter with a smart meter. When implemented properly, smart metering may benefit consumers and utility companies in certain ways. Smart energy meters can be unified with smart grids using the concept of demand response of load management for interoperability testing. The real-time information obtained from smart energy meters provides a greater understanding of consumption patterns, which are used to map the supply and demand of electricity.

The widespread use of wireless connection opens up new opportunities for the future Automatic Meter Reading (AMR), which aims to gather meter measurements automatically and issue commands to the meters. The key to technical and financial success for smart meter reading is scalable, reliable communication at a reasonable price. As a result, several service providers have experimented with various communication technologies or even created their own to discover the ideal fusion of the above factors [14], [15]. Low Power Wide Area Networks (LPWAN), a new wireless communication network that promises reliable, low-cost, long-range communication at the penalty of data speed, have recently sprung up [16], [17]. An LPWAN technology that seems especially well-suited for smart meters is Long Range Wide Area Network (LoRaWAN) [18]. With more countries opting to set up full-coverage networks in recent years, LoRa infrastructure development is accelerating [19]. Devices using LoRa operate in the license-free Industrial Scientific and Medical (ISM) radio channels at 868 MHz in Europe (as well as in Asia, Russia, and Africa) and at 915 MHz in Canada and the USA [19], [20]. Three levels of encryption offer a high-security standard, especially important for transferring users’ data [21]. A comparison, in Table 1, of prominent wireless technologies reveals LPWAN technologies like LoRa, NB-IoT, EC-GSM, LTE-M, and Sigfox typically have device-to-base-station distances of 5 km in urban areas and 25 km in rural areas, require extremely low power, have very secure communications, and have modest data throughput [22], [23].

LoRa networks, such as those using the LoRaWAN standard, fill the technological gap left by Wi-Fi, cellular, and Bluetooth Low Energy (BLE) networks. These networks either consume much power or bandwidth, have a limited range, or cannot reach deep indoor areas. LoRa devices and the LoRaWAN standard suit indoor and outdoor use cases

across various sectors, including smart cities and metering. Although 5G offers better speeds and connection, LoRa networks have a communication range of over 25 km, making them a reliable, adaptable, and affordable option for indoor and outdoor applications. LoRa combines the benefits of Wi-Fi and cellular by offering indoor coverage in the unlicensed band and security from end-user devices to the application server for outdoor use. Hence, this LoRa-based network was chosen for this work. It has proven effective results using real-time information, sensors, software applications, user interfaces, and communication infrastructure.

This study aims to enhance the awareness among users of the usage patterns of water and energy and reduce financial burden through the design and development of scalable smart water and energy meters. The primary contributions of this paper are:

- 1) The flexible design allows the water sensor to be adjusted to fit different-sized water pipes.
- 2) The smart water meter can also measure other liquids like milk and gasoline, as long as their viscosity does not negatively impact the turbine's performance in the water sensor.
- 3) The smart energy meter can monitor real-time energy consumption and detect overloading and energy theft.
- 4) The regulatory agency can remotely control the activation and deactivation of smart meters.

The remaining paper is arranged as follows. The relevant work is presented in Section II. The design and implementation of the suggested smart meters are shown in Section III. The experimental findings are covered in Section IV, followed by our conclusions and recommendations for further study in Section V.

II. RELATED WORK

Considering the advantages of traditional metering while being seduced by the possibilities offered by new technologies (e.g., reduced meter reading labor costs), utility companies are increasingly considering intelligent metering as a potential means of securing energy and water supply, minimizing waste, controlling costs, as well as transforming the customer-utility relationship. To track electricity and water usage, utility workers in India often use handheld gadgets or portable data loggers. These gadgets have sensors that gauge pressure, temperature, flow rate, and energy consumption. Portable and simple to use, handheld instruments are perfect for on-site measurements. They are useful for swiftly evaluating the effectiveness of various systems and locating potential improvement areas. These tools are frequently employed for spot checks and problem-solving. On the other hand, portable data recorders are employed for ongoing energy and water consumption monitoring over time. They can be put in place at various locations in a network to gather information on usage trends and spot patterns. These tools help to spot long-term problems and assess the efficacy of various consumption reduction techniques.

Smart meters and other Internet of Things (IoT) devices have recently become more popular for tracking energy and water usage. These gadgets allow utilities to track and regulate systems remotely while providing real-time statistics. This technology is anticipated to increase in India due to the nation's continued investment in programs to create "smart cities" and other activities to enhance the effectiveness of its water and energy infrastructure.

A. WATER METER

A water meter is vital for managing water supply systems as it estimates the water supplied from the service provider to residential or commercial structures [26]. In general, electronic, electromechanical, and mechanical types are the three kinds of water meters [27]. Table 2 briefly outlines the benefits and limitations of the three conventional types of water meters.

Electromechanical water meters, whose estimation premise is yet mechanical [28], are mechanical water meters integrated with electronic circuits to give programmed functionalities such as Automated Meter Reading (AMR). As AMR are battery-less systems, memristors can be employed to back up the measured data as memristors have low footprints and are non-volatile [29], [30], [31]. Electronic water meters have been developed as a result of recent advancements in measurement technology, including electromagnetic [32], fluidic [33], and ultrasonic-based water meters [34]. An electromagnetic water meter works based on the electromotive force that the fluid experiences as it passes through a magnetic field, and the induced electromotive force is proportional to the fluid's velocity. The Coanda effect [35] states that fluid velocity is proportional to the oscillation frequency induced in the water pipe by the water flow, a principle used by fluidic water meters. The ultrasonic water meter computes the fluid velocity by sending ultrasonic sound waves using ultrasonic transducers through the fluid. In improving the monitoring of water consumption, electronic water meters are the potential meter for smart cities as their measurement accuracy is frequently higher than that of mechanical ones.

A water flow meter with an electromagnetic sensor was designed that measures the fluid amount by measuring the flow velocity [36]. Proportional to the fluid velocity, a potential difference is formed across the electrodes. The water flow meter, however, only managed to reach a poor accuracy of 85%. The Hall effect flow sensor, Arduino Uno, Raspberry Pi, and cloud infrastructure were used to construct a smart water meter. The Arduino Uno received pulses from the flow sensor and sent data to the Raspberry Pi [37]. For the user to visualize the data, the Raspberry Pi analyses the raw data and stores it on a web server. The data and the prediction algorithm are utilized for invoicing purposes to foretell consumer needs. The water flow meter uses an Arduino and Raspberry Pi in tandem, which makes the hardware more complicated. Raspberry Pi or Arduino may have been utilized to cut costs and complexity. Two piezoelectric sensors were utilized to

TABLE 1. Analysis of Various wireless enabling technologies [22], [23], [24].

Wireless Network	Operating frequency	Bandwidth	Communication speed	Communication Range	Security	Power consumption
NFC	13.56MHz (Unlicensed)	14KHz	Upto 424 Kbps	10 cm	TDES, AES, RSA and ECC	0.2 W (Near Field)
Bluetooth and BLE	2.4GHz (Unlicensed)	1MHz (Bluetooth) 2MHz (BLE)	1 Mbps (Bluetooth) 2 Mbps (BLE)	100 m (Bluetooth) <100 m(BLE)	AES-128	1mW to 100mW
Z-Wave	900 MHz (Unlicensed)		9.6,40,100Kbps	30 m	AES-128	1mW
ZigBee	2.4GHz (Unlicensed)	2MHz	250Kbps	100m	AES-128	15mW
Wi-Fi	2.4GHz and 5GHz (Unlicensed)	20-40MHz	802.11a: 54Mbps, 802.11b: 11Mbps, 802.11g: 54Mbps, 802.11n: 600Mbps, 802.11ac:6900Mbps, 802.11gac: 1600Mbps [25]	50m	AES-128	>900mW and 50mW in sleeping mode
Sigfox	868/902/928 MHz (Unlicensed)	100Hz	300 bps	50 Km	AES	25mW
LoRa	868/915 MHz (Unlicensed)	125KHz	50Kbps	25Km	AES-128b	25mW
NB-IoT	900 MHz (Licensed)	180KHz	250Kbps	10Km	LTE Encryption	100/200mW
LTE-M	1800 (B3)/900 (B8)/800 (B20) MHz (Licensed)	5MHz	1 Mbps	10Km	LTE Encryption	100/200mW
4G	700/800/900/1800/2600 MHz (Licensed)	20 MHz	12 Mbps	10Km	LTE Encryption	200mW
5G	3.6 GHz (Licensed)	500 MHz to 2 GHz	100 Mbps	1 Km	LTE Encryption	200mW

TABLE 2. Analysis of existing water meters [27].

Type	Strength	Weakness
Mechanical Water meter	Low cost, low complexity, and long-term reliability.	Low flow rates lead to constrained measurement range, reduced precision, and a shortage of real-time data.
Electromechanical	Real-time data.	Reduces stability and needs additional safeguards for the electronic components.
Electronic	Real-time data with excellent precision.	Needs a power source and additional safeguards for the electronic components.

determine if the water flow was cold, hot, or mixed [38]. The water flow sensor has a 96% accuracy rate. Although the system can distinguish between cold, hot, and mixed water, it does not reveal how much water is consumed. One piezoelectric sensor may have been sufficient to carry out the entire process in place of two. A hybrid electrical/mechanical water metering system with a 95% accuracy was developed for real-time water monitoring and leak detection utilizing the Global Satellite for Mobile Communication (GSM)/ General Packet Radio Service (GPRS) module [39]. The processing of the sensor’s data by a Field Programmable Gate Array (FPGA) chip found in a water meter raises the system’s overall cost.

The data captured by the ultrasonic sensor-based water flow meter was delivered to the user via text message through the GSM module, allowing for real-time measurement of the water flow [40]. The ultrasonic sensor-based water meter functions best in rust-free, clean pipelines, and for increased accuracy, the pipe must be filled with water without air gaps. A system with IR and laser sensors was used to monitor the flow rate of distilled water, coconut oil, and glycerin flow [41]. Analog to Digital Converter (ADC) technology was used to transform the analog data from sensors to digital data, which FPGA processed. Compared to IR sensors, laser sensors have proven to be more accurate. A water flow meter that processes data using an FPGA is rather pricey. The leak was discovered using a system that measures water flow using a Hall effect sensor and processes the data using a Raspberry Pi 4 [42]. If the measured data of liters per hour is greater than zero but less than a predetermined level of water use, leakage has been discovered. Even with little water pressure in the pipe, water leaks would still be recorded. A self-powered water flow meter was developed using a Hall effect sensor and an Arduino Uno, with the remote relay switch controlling the key operating features [43]. The system functions as a harvester when the relay switch is closed. It charges the battery, which then powers up the complete system. In the open position of the relay switch, the system is utilized to measure the water flow rate. The gadget won’t work as a water flow meter when used as an energy harvester, which prevents it from providing data on overall water usage. A water turbine generator is used in the water meter to achieve flow monitoring and power generation with a Bluetooth transmitter [44].

With a range of around 10 meters, the Bluetooth transceiver can reach a limited area. The following section discusses the contributions made by researchers on energy meters.

B. ENERGY METER

The amount of energy a country uses directly affects its development factor. It serves as a potent metaphor for social progress. The infrastructure reliant on power and its availability underpins the residential and business sectors. It is essential to find alternative renewable resources or ways to stop the depletion of the present resources without harming the environment to meet the rising demand. As mentioned above, the concept may be realized by wise resource use, careful planning, and initiatives to identify alternate technological choices. Electricity is measured using traditional meters that use aluminum discs to determine power use. Digital meters have taken the role of analog meters; however, the limitation still exists. Conventional meters are unreliable as consumers must budget for their monthly power bills, and the billing process requires manpower hence is expensive and time-consuming. Compared to a traditional energy meter, a smart energy meter detects a consumer's energy usage and gives the utility provider additional information [45]. Smart meters continually track energy use and relay this information to customers and utility providers at predetermined intervals.

Conventional energy meters, their operating theories, and the development of the smart energy meter with its improved features are all covered in a study [46]. Consumer impressions of smart energy meters and their merits over electromechanical energy meters were the subjects of another research [47]. An AT89S52 microcontroller is attached to an energy meter, which reads and displays the energy meter readings on an LCD screen [48]. A GSM modem is utilized to send data by SMS. The energy meter, however, is unable to identify electricity theft. The numerous wireless communication technologies used in smart energy meters, including WiMAX, ZigBee, and GSM modules, were the subject of a study [49]. With the aid of a PIC microcontroller, a GSM/GPRS module, and a user-friendly Graphical User Interface (GUI), an Automatic Meter Reading (AMR) system was created that allows users to authenticate properly and monitor their energy use from anywhere in the globe [50]. An Arduino and Wi-Fi module that transmits power/unit data to the cloud [51] and a smart energy meter using a GSM module [52] are prioritized for improved energy measurement and billing. However, the system lacks functionality for overloading and electrical theft detection. For data logging and storage, energy meters equipped with MicroSD slots are employed [53]. Real-time energy theft detection and two-way communication between meter and cloud utilizing a Wi-Fi module have been built using IoT protocols [54]. If the user exceeds the permitted load limit, the customer won't know about the overloading. Energy and water conservation are necessary, especially in a population-rich country like India. As a result, a system that can assess energy and water in real

time is demanded, offering advantages for both consumers and service providers.

C. INTEGRATED WATER AND ENERGY METER

The two most abundant resources used are energy and water. If not properly controlled and monitored, they could also be the biggest source of waste. Measuring and keeping track of an organization's water and energy usage is crucial since it can help in several ways. Although there has been a lot of work on energy and water meters, there has been less effort on integrated water and energy systems.

A literature review reveals that current water meters face challenges such as a lack of remote connectivity, high initial investment costs, and low accuracy. Similarly, the energy meters in smart city infrastructures have limitations in detecting overloads or electricity theft. Additionally, there is a need for better utilization of wireless technologies to extend the service area. This study aims to create a comprehensive system that can effectively manage the connection status, track water, and energy usage, and identify instances of overloading and electricity theft. The proposed system minimizes expenses for customers and regulatory agencies by enabling remote control and monitoring capabilities. The study aims to address key challenges in smart cities by developing a smart water and energy meter system. The research objective is to design a unified system that includes the following:

- 1) A Smart Water Meter utilizes a water flow meter that accurately determines water consumption to measure total water usage and generates the water bill for the water consumed.
- 2) A Smart Energy Meter calculates electricity consumption by measuring power, power factor, energy, frequency, current, and voltage and generates the bill for the consumed energy. The meter also detects overloads to prevent penalties and electricity theft by the user.

The research aims to link smart water and energy meters via communication utilizing LoRa technology.

III. SYSTEM DESIGN AND METHODOLOGY

Owing to technical improvements, creating a wireless network over a large area is no longer a problem. Smart cities' practical water and energy metering device design integrates wireless modules with appropriate IoT-based controllers. This section describes the system architecture and methodology for the proposed integrated residential water and energy consumption monitoring system.

A. SYSTEM DESIGN

The developed system in this research intends to provide a smart water and energy meter to analyze water and energy use while considering the sensor node's energy consumption. The block diagram for the suggested integrated system is shown in Fig. 1.

The smart water meter and smart energy meter are installed in a residence, where the smart water meter monitors water

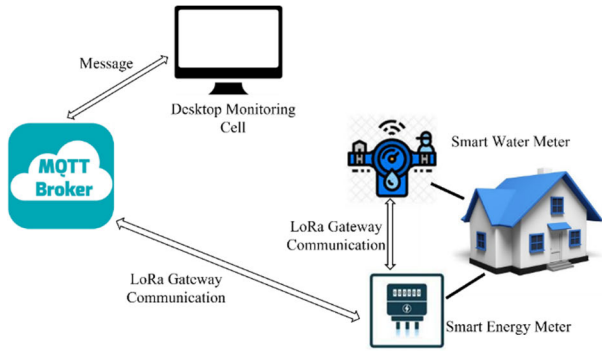

FIGURE 1. Block diagram of the proposed integrated system.

consumption and interacts with the smart energy meter. Along with detecting the amount of energy used, the smart energy meter collects data from the smart water meter, and on-demand, transmits the data to the utility provider. Smart meters connect with the utility provider and one another using the LoRa communication protocol. Message Queuing Telemetry Transport (MQTT) is the protocol to connect the LoRa gateway and the Network Server. Semtech developed the low-frequency modulation method known as LoRa. This technique aims to achieve minimal power usage and long-range communication between devices. Low frequency (1GHz) is used to accomplish both of these objectives. LoRa networks have a greater range and less energy usage than Wi-Fi and cellular networks, which require higher bandwidth. A free, open-source protocol named LoRaWAN has been created by the LoRa Alliance to go over the LoRa technology. With the help of this protocol, LoRa devices will be securely connected to the internet. The objective is to maximize battery life while enabling internet communication on battery-powered devices.

A LoRa device uses the LoRa technology to deliver frames and packets in all directions when communicating over the internet. Then, this packet will be received by one or more Gateways. The Gateways' LoRa packets are demodulated and forwarded over the internet to the Network Server. As stated, the Message Queuing Telemetry Transport (MQTT) protocol is used in many LoRa implementations to create a dialogue between the Gateways and the Network Server. Messages are sent between devices using the publish-subscribe protocol MQTT. The "MQTT broker" server, which collects the messages and clients that can read from or write to the broker, is the two components of the MQTT protocol. Clients should provide the topic they wish to write about and subscribe to since it is a publish-subscribe protocol. The integrated metering system's units are depicted in block diagram form in Fig. 2.

The smart water meter utilizes a Raspberry Pi Pico, a Hall effect water flow sensor, and an E32/1W LoRa module. The 12V is converted to 5V by a voltage regulator in a regulated power supply. The 5V from the regulated power supply is supplied to the water flow sensor, solenoid valve, LoRa

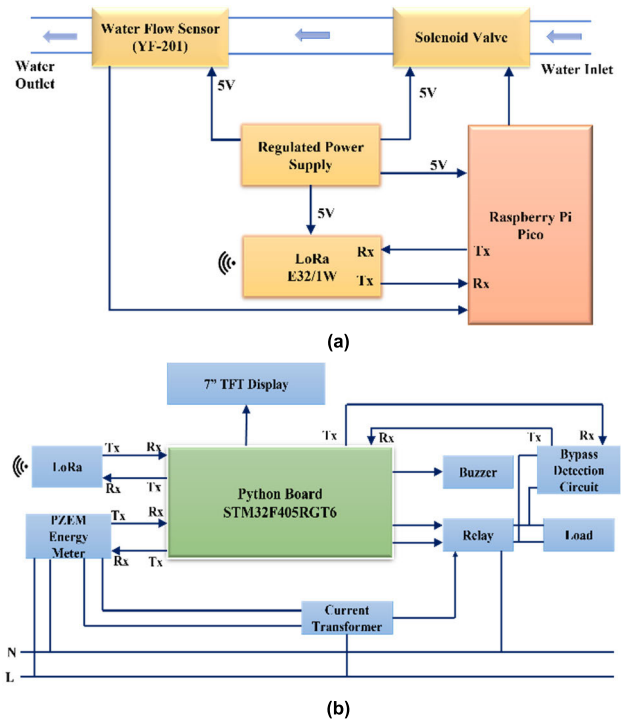

FIGURE 2. Block diagram of the individual units of the integrated system: (a) Smart water meter and (b) Smart energy meter.

module, and Raspberry Pi Pico respectively. On the other hand, the smart energy meter combines a Python board with a PZEM energy meter, a LoRa module, and a bypass-detecting circuit. The system's brain, a Raspberry Pi Pico and Python board, drives all necessary operations. A water flow sensor is linked to the Raspberry Pi Pico to collect real-time data. The Python board receives the measured energy consumption from the PZEM energy meter. The water pipeline is connected with a solenoid valve, and the relay connected to the load is connected and disconnected remotely under the command of the Raspberry Pi Pico and Python board, respectively. The Raspberry Pi Pico controller will save the data on energy use and water consumption collected by the YF-201 water flow sensor. The regulatory board will receive the data through an E32/1W LoRa module whenever necessary. When a signal to obtain data for remote access is received from the regulating company or when the sensor detects an interruption, LoRa wakes from sleep mode. The following subsections describe how the Hall effect water flow sensor, a driver circuit, a solenoid valve, and a PZEM energy meter operate.

B. HALL EFFECT WATER FLOW SENSOR-YF-S201

From a qualitative and financial perspective, accurate flow measurement is crucial. Water flow may be measured accurately with the use of flow meters. This study develops a water management system using the water flow sensor YF-S201. Fig. 3 depicts the structure of the YF-S201 sensor. The YF-S201 turbine flow sensor with pulse output com-

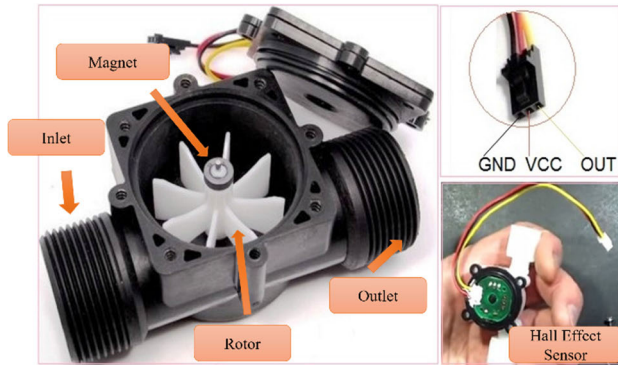

FIGURE 3. Different parts of YF-S201.

prises a water rotor placed inside a plastic body. When water flows through the sensor, the magnetic rotor spins, and the rotor rotational speed varies with the flow rate. The Hall effect sensor circuit works on the electromagnetism concept and creates pulse output at the appropriate output pin. This low-power gadget has a maximum capacity of 30 liters per minute, using only 15-20mA at 5V. The sensor has a red wire for powering it with DC power ranging between 5 to 24V, a black wire for grounding, and a yellow wire for the Hall effect sensor's PWM (Pulse Width Modulation) output. When water flows through the sensor, the turbine blades experience torque, which drives the rotor. After a steady rotation speed is achieved, the rotational speed is equivalent to the fluid velocity. As a supplementary rotational speed measuring tool, the YF-S201 detects the turbine's rotor velocity with a Hall effect sensor.

The inbuilt Hall effect sensor generates an electrical pulse for each rotation. The sensor is kept dry by being isolated from the water pipe. The water flow estimation is simplified by counting the number of pulses obtained at the output of the Hall effect sensor. Each pulse is equivalent to 2.25 milliliters of water. Based on parameters such as sensor orientation, fluid pressure, and flow rate, the pulse rate in the sensor fluctuates.

C. MOTOR DRIVER IC-L293D

The L293D motor driver IC drives the solenoid valve, which receives the command from Raspberry Pi Pico. The L293D is powered by one of its two voltage pins, the other is used to apply voltage to the valve. In response to Pico's input, the L293D output signal changes from 0 to 1 and 1 to 0. Fig. 4 depicts the two H-bridges that makeup L293D. Modifying the polarity of the input voltage is a viable method for altering the spinning direction of a DC motor. An H-bridge is a common method for accomplishing this. The motor is located at the center of a four-switch H-bridge circuit, forming an H-shaped structure. The voltage polarity supplied to the motor is reversed by shutting two specific switches. As a result, the rotational orientation of the motor shifts.

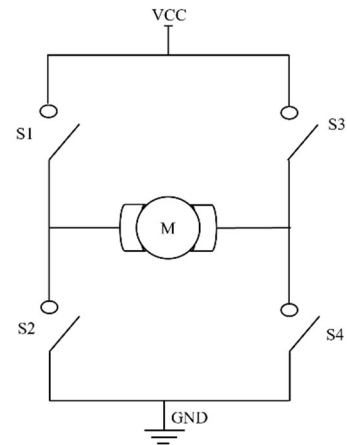

FIGURE 4. H-bridge with four switches.

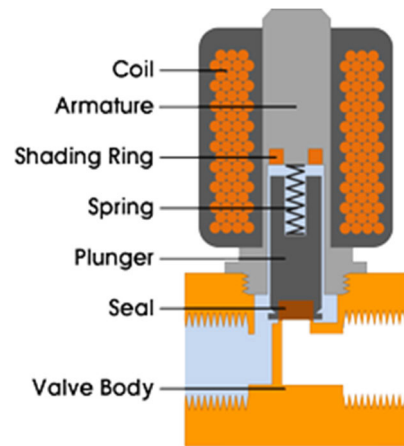

FIGURE 5. Solenoid valve components.

Keeping the switches S1 and S4 closed while leaving the switches S2 and S3 open results in a path for the current to flow from VCC to switch S1, then to the motor, then to switch S4, and finally to the GND making the motor rotate in one direction. The motor can rotate in either a clockwise or counterclockwise direction since its rotation depends on how its terminals are connected to the switches. Closing the switches S3 and S2 and opening the switches S1 and S4 causes the motor to rotate in opposite directions as current flows through switch S3, the motor, switch S2, and the ground. The motor shaft stops when a positive voltage is provided to both sides, that is, when S1 and S3 are closed, leaving the other two switches open.

D. SOLENOID VALVE

The internal structure of the solenoid valve is shown in Fig. 5. Solenoid coil is triggered by passing electricity, creating a magnetic field. The magnetic field pushes the plunger toward the coil's center in a Normally Closed (NC) valve, allowing the medium to pass through by opening the orifice. The converse is true with Normally Open (NO) valves, which

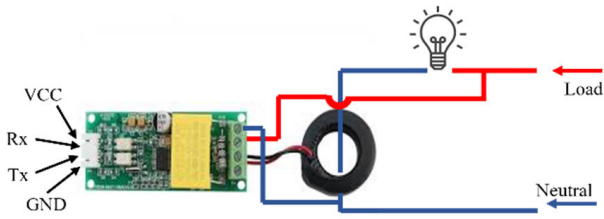

FIGURE 6. Wiring diagram showing test input terminals and serial communication wirings.

operate such that the orifice is open even when the solenoid coil is not energized. Orifice closure occurs when the solenoid is triggered. A transient power source can switch a latching or bi-stable solenoid valve. It continues to stay in the same position even with no power. Thus, it is neither NO nor NC because it maintains its current state without power. Instead of a spring, they use permanent magnets to achieve the opening and closing operation.

E. PZEM-004T

The parameters such as energy, power, power factor, frequency, voltage, and current are measured using the electronic module PZEM-004T by live monitoring the AC main lines. Three distinct current measuring choices are included with this module: a built-in shunt resistor with a 10A range and an external current transformer with a 100A range. The 100A range module requires the neutral line connected to the load to pass through the core of the current transformer. The brain of the PZEM-004T module is V9881D, a single-phase energy meter system-on-chip. The Peacefair Electronic Technology Co., Ltd. sensor PZEM-004T has eight pins, two for powering the sensor, two for establishing opto-coupled TTL serial communication, and four to serve as voltage and current inputs. The wiring diagram of PZEM-004T is shown in Fig. 6. Furthermore, PZEM004T is an inexpensive power sensor with the best performance [55].

A smart water flow and energy meter are formed by arranging and putting all the components together. Once the components have been put together into a single enclosure, they are further linked to gauge energy and water usage in the residential area.

F. BYPASS DETECTION CIRCUIT

The voltage supplied before the energy meter is detected by the input voltage sensing circuit, and the voltage supplied after the energy meter is detected by the output voltage detecting circuit. The bypass detection circuit’s block diagram is shown in Fig. 7. A rectifier, optocoupler, voltage divider, and capacitor make up the sensing circuit. The sensing circuit output is fed into a dual operational amplifier, which compares both outputs and produces logical output based on differences between the values. The controller accepts the logical outputs and checks for unusual circumstances, such

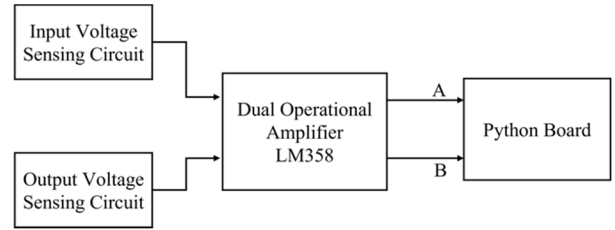

FIGURE 7. Block diagram of the bypass detection circuit.

TABLE 3. Response for various voltage conditions.

The output of dual operational amplifier		Remarks
A	B	
0	0	No power
0	1	Theft detected
1	0	Line Disconnected
1	1	Line Connected

as electricity theft. Table 3 below displays the logical outputs with the response of the controller.

G. METHODOLOGY

1) SMART WATER METER

The water flow sensor detects the movement in the water pipe, and the Hall effect of the flow sensor transforms the movement into pulses. The zero output is detected when the pipeline valve is closed, meaning there is no pulse since there is no water flow. The Hall effect motion generated due to water flow when the valve is opened is converted into pulses by the sensor, which is then converted to a measured value. The calibration coefficient also represents the output of the Hall-effect flow sensor. This factor is changed to allow for precise estimation. The calibration coefficient changes in response to water pressure and pipe diameter changes. As no loop is guaranteed to end precisely a second, the output is measured milliseconds from the last execution.

The flow rate computation considers the count of the number of pulses per second for each unit of measurement, along with the calibration factor that impacts the flow rate (FR), as mentioned in (1). The one-second sensor data calculates the current amount of water that goes through the water sensor in milliliters, as mentioned in (2). The total amount of water that passes through the sensor in milliliters is computed by (3). Once the water stops flowing through the sensor, the time required to analyze the current water remains constant. As a result, the present time is the same as before. The water flow has ceased. The Current Time (CT) and previous scan time (PT) in milliseconds, Current Pulse (CP) count, and Calibration Factor (CF) of the water flow sensor is considered in the evaluation concerning the flow in the current time stamp designated by $flow_t$ and the flow concerning to the previous time stamps identified as $flow_{t-1}$ and the variable

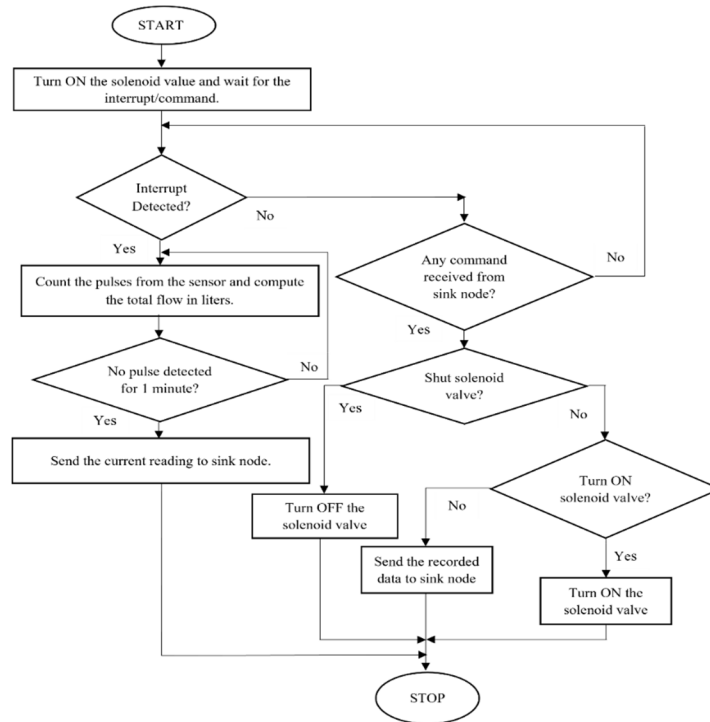

FIGURE 8. Flowchart displaying the several steps of the proposed process.

t_f denotes the total flow in milliliters.

$$FR = \frac{\left(\left(\frac{1000}{CT-PT}\right) \times CP\right)}{CF} \quad (1)$$

$$Flow\ in\ Milliliters = \left(\frac{Flowrate}{60}\right) \times 1000 \quad (2)$$

$$t_f = flow_t + flow_{t-1} \quad (3)$$

The controller sets all the parameters to determine the overall water flow to “0”. When a system is newly installed, billing is unaffected by this initialization. Following a series of processes, as seen in Fig. 8, the approach used is as follows:

- 1) The driving circuit opens the bi-stable solenoid valve by receiving a 10ms pulse from the controller.
- 2) While the water runs through the pipeline, the Hall Effect sensor is affected by the magnetic flux caused by the turbine wheel’s rotation. Because the interference rate depends on the water’s flow velocity, the sensor generates a pulse signal to calculate the water quantity.
- 3) The Raspberry Pi Pico’s interrupt pin receives the flow sensor’s output and keeps a running tally of the pulses per unit of time. The number of interruptions is directly proportional to the rate of water flow. As a result, the total water flow in liters is estimated using the water flow sensor’s pulse count.
- 4) The total volume measured will be retained for the subsequent calculation when there is no water flow for a predefined period of 1 minute.

TABLE 4. Adjustment of calibration factor.

Iteration Count	Calibration Factor	True Value in milliliters	Measured Value in milliliters
1	3	1000	2050
2	3.5	1000	1800
3	4	1000	1250
4	4.5	1000	1010
5	5	1000	800
6	6	1000	500

- 5) The Solenoid valve is remotely turned OFF for delayed/no bill payment and is turned ON upon successful bill payment. Turning ON/OFF the solenoid is done remotely, thus avoiding a physical visit to the site.
- 6) To reduce power consumption, the unit’s operating hours must be cut. As a result, while no processes are in operation, the LoRa module goes into sleep mode.

Selecting the right calibration factor value to increase accuracy necessitates a trial-and-error process. The proximity between real and measured values increases with accuracy. The true and measured values for different calibration factors are shown in Table 4. The calibration factor works best when the actual and measured values are near. When the calibration factor is adjusted appropriately, the system is intended to offer an accuracy of at least 95%.

The experimental approach involved passing 1000 ml of water through the sensor and subsequently comparing the observed value with the calibration factor initially set to 1.

The procedure is then repeated by increasing the calibration factor value till the measured value is as close to the real value as possible. In the current study, a higher degree of precision for the calibration factor of 4.5 is attained using the approach of trial and error. The sensor must have 0.5 bar of water pressure to function. This precaution prevents the sensor from creating pulses due to the air circulation within the water pipe. Each parameter's value is updated using the most recent measurement, which serves as the baseline for subsequent measurements.

2) SMART ENERGY METER

Whenever the electricity board issues directions to the smart energy meter module, the solid-state relay is used to "Connect" or "Disconnect" the load. The consumer load power theft is found using the bypass detection circuit. The circuit delivers a digital high signal to the processor if the consumer bypasses the meter and connects directly from the mains to the load. Additionally, the controller sends a notice about the power theft to the monitoring cell. The brain of the smart energy meter is the STM32 processor. It keeps track of all the smart energy meter's features. The processed data is displayed on the LCD (Liquid Crystal Display) display and transmitted over a LoRa gateway to the regulating board. Fig. 9 shows the methodology adopted for the smart energy meter, and the process of operation is as follows:

- 1) Three operations are running simultaneously in the smart energy meter, monitoring the energy consumed, the overload, and waiting for a command from the regulatory board.
- 2) Energy will be monitored continuously and is displayed in the TFT (Thin Film Transistor) LCD. The data displayed are power, voltage, frequency, current, energy consumed, and power factor associated with the consumer. It also displays the water consumed data from the smart water meter and an alert message.
- 3) A buzzer sound and a message notify the user if the load consumed exceeds the allocated load. If the overload persists for more than 5 minutes, the amount charged for each unit will be doubled.
- 4) If the smart energy meter receives a command from the smart water regulatory board, the smart energy meter, in turn, communicates with the smart water meter to perform the task, such as turning ON/OFF the solenoid valve or receiving the data of water consumed. The smart energy meter sends the data received to the water regulatory board.
- 5) In the event of failed bill payment, the electricity board sends a command to the smart energy meter via a smart pole to disconnect the line and activate bypass detection. If the bypass detection circuit detects electricity theft, the smart energy meter returns the message to the electricity board.

- 6) In the event of bill payment, the load will be connected to the line remotely upon receiving the command from the electricity board.

Address of the slave + 0x04 + Higher byte of Register Address + Lower byte of Register Address + Higher byte of Number of Registers + Lower byte of Number of Registers + Higher byte of CRC Check + Lower byte of CRC Check is the command format that the control board employs to send the command to read the sensed data. The energy meter address is the slave address, and in a single slave scenario, 0xF8 serves as the general address. Following the address of the register to be read is the instruction for reading the input register, which is 0x04. The word "Number of registers" followed by the CRC code designates the number of registers that need to be read. Address of the slave + 0x04 + Number of Bytes + Higher byte of Register 1 Data + Lower byte of Register 1 Data + ... + Higher byte of CRC Check + Lower byte of CRC Check is the instruction format that the energy meter uses in the response. The voltage values are stored in the first register and current values are stored in the second and third registers, respectively, each of 16-bit. The fourth and fifth registers store the value of power, the sixth and seventh register the value of energy, the eighth register the value of frequency, and the ninth register the value of power factor. The values are all kept in hexadecimal, and after performing shifting and logic OR operation, they are converted to a decimal value for display [56]. The discussion of further findings from experimental research is described in the next section.

IV. EXPERIMENTAL RESULTS AND DISCUSSIONS

The current section outlines the experiment findings and inferences. The system's efficacy is evaluated through testing, utilizing intelligent energy and water meter design.

A. TESTING THE ACCURACY OF THE SMART WATER METER

To test the water flow meter's ability to precisely detect the volume of water flowing through a pipe, the prototype is connected to the house's water supply input line. The hardware setup is shown in Fig. 10. The system is tested by pumping water via a 1/2-inch conduit. The measured data and the water gushing out of the hardware are compared. Using a LoRa module, the energy meter unit receives and displays the measured water flow value. How wireless sensor networks access and manage the energy needed for continuous operation is a problem for smart water meters and wireless sensor networks. Externally powered devices are not a wise choice from the service provider's perspective. The location of the water meter is often away from any source of immediate electricity. Solar power is among the most widely adopted options for renewable energy for use in embedded systems and wireless sensors. A solar cell is the best choice for powering embedded components in wireless sensor networks due to its high-power density.

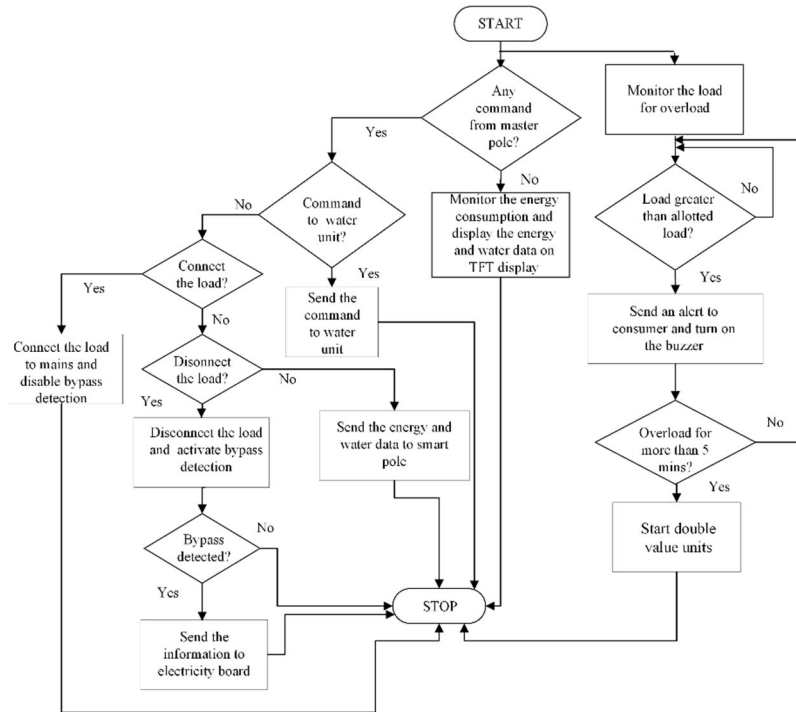

FIGURE 9. Flowchart illustrating the steps in the process.

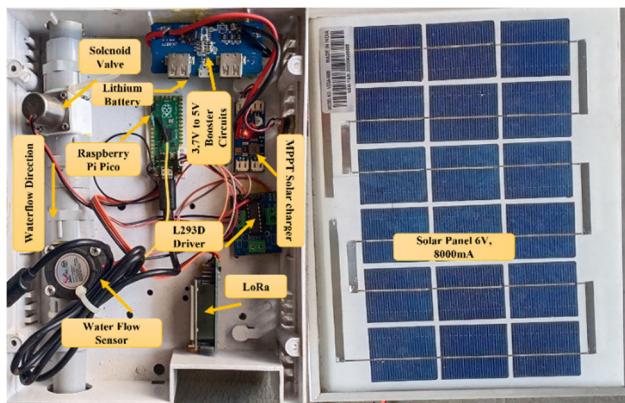

FIGURE 10. Design and the components of the smart water meter.

For numerous iterations, tests are conducted to gather data using 1000ml of water to assess the water flow meter’s accuracy. According to Table 5, data is recorded by the smart water meter with 99% relative accuracy. As shown in Fig. 11, the measured and actual values are quite close in all five iterations.

B. HARDWARE SETUP OF SMART ENERGY METER

The smart energy meter for measuring energy consumption is set to read specific premises’ energy consumption and transmit that information to the utility center. The smart energy meter is also set up to detect consumer-side theft and to remotely connect or disconnect the line from the

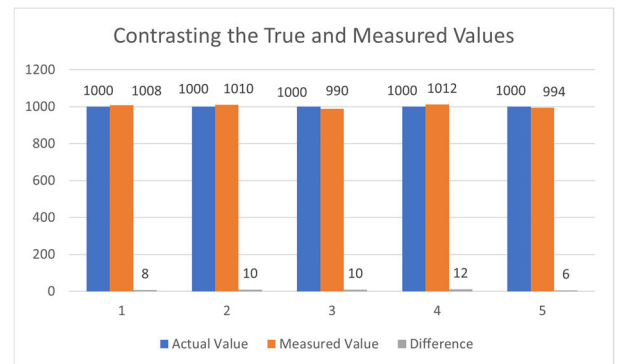

FIGURE 11. Comparison between the water flow’s real amount and measurement, using a 4.5 calibration factor.

TABLE 5. Experimentation data.

Number of Iterations	Actual Value	Measured Value	Accuracy
1	1000	1008	99.2%
2	1000	1010	99%
3	1000	990	99%
4	1000	1012	98.8%
5	1000	994	99.4%

load. The work’s hardware implementation is depicted in Fig. 12. On the TFT LCD screen, parameters including voltage, current, power, energy, power factor, and frequency are displayed. The solid-state relay is used to “Connect” or

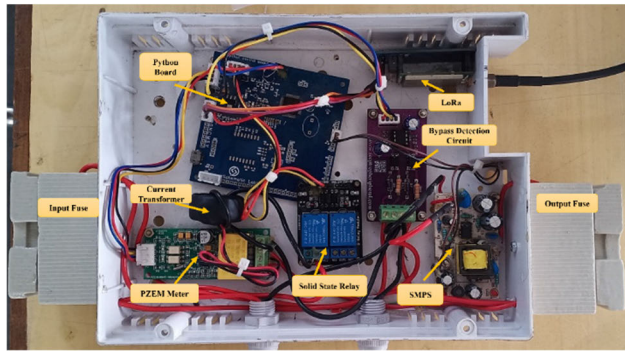

FIGURE 12. Prototype of the smart energy meter.

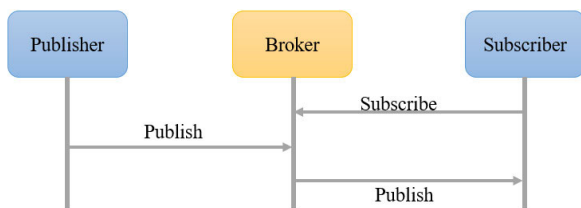

FIGURE 13. Publish/Subscribe architecture of MQTT.

“Disconnect” the load whenever the electricity board sends commands to the smart energy meter module. The bypass detection circuit is used to identify the power theft in the consumer load. If the consumer directly connects from mains to load by bypassing the meter, the circuit sends a digital high signal to the processor. The processor further sends this signal to the utility center.

C. DATA GATHERING

Traditional client-server architecture can be replaced with the MQTT publish/subscribe paradigm. The publisher is the client sending the message, and the subscriber is the client receiving the message. According to the publish/subscribe model, the client transmitting a message is independent of the client or clients that are receiving the message. No direct communication is possible between publishers and subscribers. The existence of one another is unknown to both the publisher and the subscriber. A third-party broker manages the communication between the publisher and subscriber. The broker must filter all incoming messages to be properly distributed to subscribers. Eclipse Mosquitto, an open-source message broker, is used by low-powered single-board computers to large servers. Hence, the broker is adaptable and portable for usage on various equipment. The MQTT protocol provides a straightforward method for sending messages using a publish/subscribe strategy. This qualifies it for IoT messaging, such as with low-power devices and sensors. Fig. 13 depicts the publish/subscribe communication model showing the source and sink interaction.

The best part of the MQTT protocol is the Android app ‘MyMQTT’ for subscribing to and monitoring events. The Android client’s splash screen and subscribe screen are depicted in Fig. 14. Using the unique topic `/device-metrics/smart_home_1_send`, the client is subscribed to a

device. Once subscribed, the user can access the topic `/device-metrics/smart_home_1_recive` along with the message to access the source and obtain the necessary data. The topic and message “total liters” issued by the subscriber to collect the data from the water meter are shown in Fig. 15(a). The broker receives the published message and then sends it to the smart energy meter module. After receiving the command from the broker, the energy meter communicates with the water meter module to collect the total liters consumed. Fig. 15(b) shows the data of the water meters received through the energy meter module sent via a broker to the subscriber. The subscriber receives the message “home1_no_alerts” if no published messages or smart energy meter alerts have been received. Fig. 16 depicts the messages communicated with the smart energy meter. As shown by Fig. 16(a), the topic and message “send units” were transmitted from the subscriber to the client via the broker. As shown in Fig. 16(b), the energy meter sends the subscriber the recorded energy consumption data in units in response to the command. Additionally, as shown in Fig. 16 (b&c), the subscriber receives the alert message without any request to take appropriate action in the event of a power overload or power theft.

A 7" TFT display keeps the consumer informed about energy use, water use, and alerts like power overload, electricity disconnection, and water disconnection. Nextion Editor is used to create the Human Machine Interface (HMI) Graphical User Interface (GUI) for the TFT display, as seen in Fig. 17. To make it simpler for the average person to grasp, the cells are designed to display all the necessary data separately. Voltage in Volts, current in Amperes, power in Watts, units consumed in Watts/hour, power factor, frequency in Hertz, total water consumed in liters, and alerts are displayed metrics.

The integrated system’s real-time data measurements are successfully communicated between the smart water and energy meters using the LoRa network. They are displayed on the TFT display in Fig. 18&19. Any alert message linked to an energy meter is displayed in the first row of the alerts cell, while alerts related to a water meter are displayed in the second row. The real-time water consumption of 2.33 liters is recorded and can be observed by the ‘Total/Ltr’ parameter changing from 6.24 to 8.57 in Fig. 18(a&b). The real-time electricity consumption is depicted in Fig. 19(a&b). Changes in the electricity supply are inevitable, and it ranges from 220-240V. The system is designed to have a tolerance level of $\pm 5\%$.

The energy used by a residence on a day with five 14-watt LED bulbs, a 324-liter refrigerator, an LED television, three electric fans, an electric water heater, a grinder, and a water filter is depicted in Fig. 20(a). Fig. 20(b) displays the energy consumption for a week. Similarly, Fig. 21 depicts a home’s water usage with a three-member family over a week.

D. CONTRAST WITH EXISTING METERS

Tables 6 and 7 summarize the key differences between existing energy meters with the proposed integrated smart water

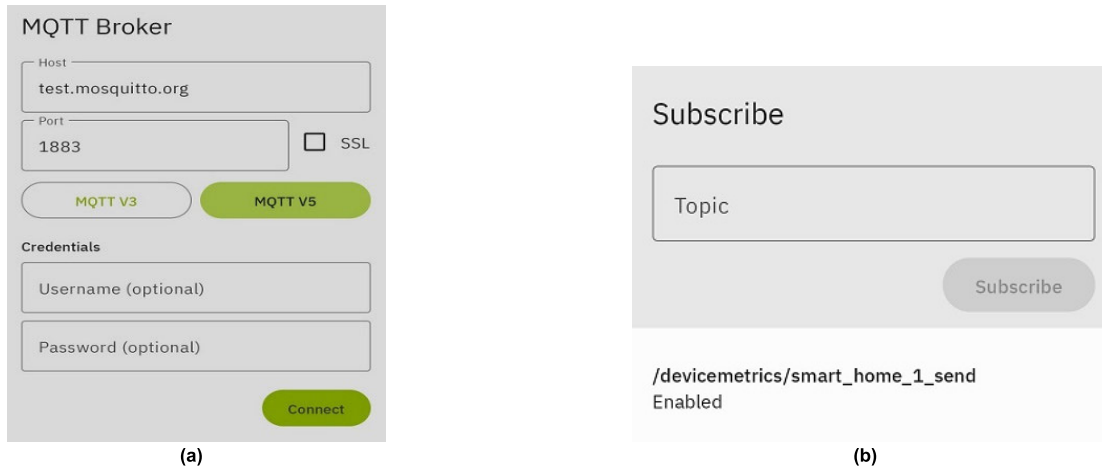

FIGURE 14. Android MQTT Client: (a) Lunch screen and (b) Subscribing to the broker using the topic.

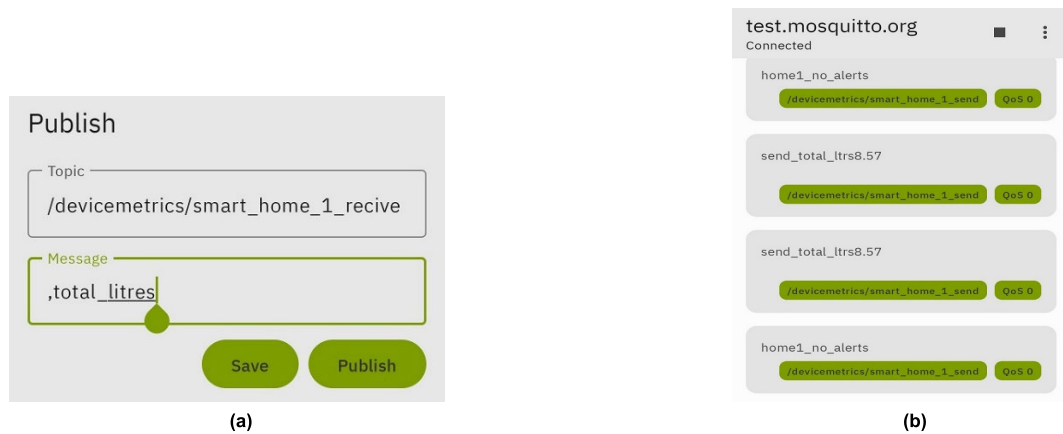

FIGURE 15. Android MQTT Client: (a) Topic and message published to gather the water meter data and (b) Data received from the water meter and displaying no alerts from the energy meter.

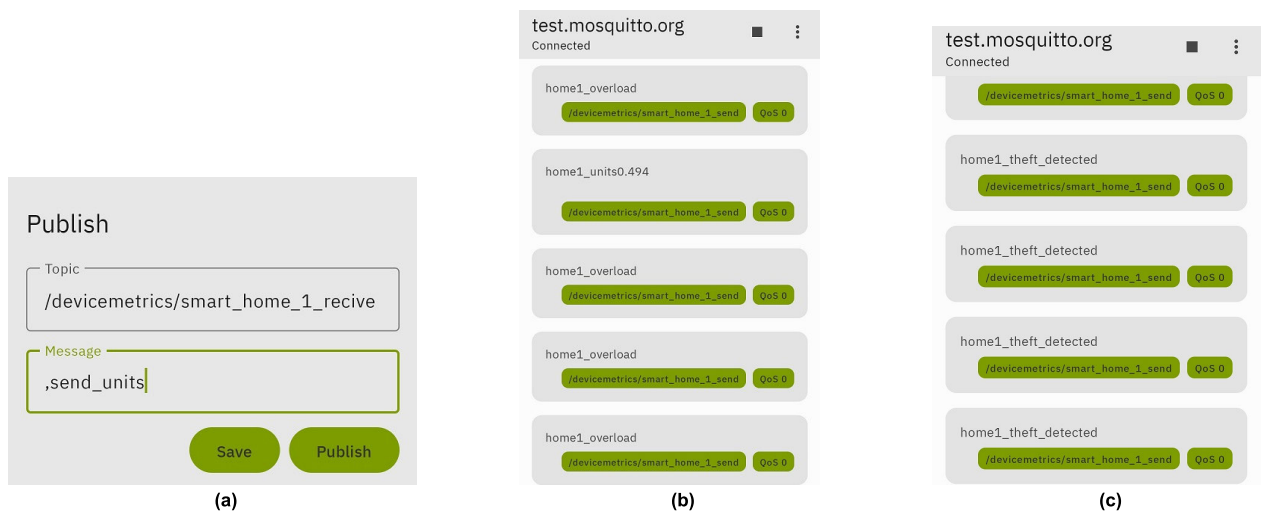

FIGURE 16. Android MQTT Client: (a) Topic and message published to gather the data of energy meter, (b) Data received from the energy meter and displaying overload alerts, and (c) Theft detection alert.

and smart energy meters. From Tables 6 and 7, it is evident that the proposed integrated system offers more benefits making it feasible for users to monitor their water and energy consumption at any time.

Table 8 highlights the important features of the proposed integrated smart water and energy meter. The integrated system is designed to enable two-way communication, has a solar-powered water meter, offers remote control of



FIGURE 17. GUI designed using nextion editor.

TABLE 6. Comparison of existing smart water meters.

Sl. No.	Meter Type	Highlights	Disadvantages
1.	Electromagnetic Water Meter [36]	Accuracy of 85%, measured data is sent to the recipient through GSM and solar powered.	High cost, lacks remote monitoring, and lacks communication with the service provider.
2.	Hall Effect Sensor [37]	Prediction algorithm for managing the water demand.	The user is unaware of daily water consumption and lacks communication with the service provider.
3.	Piezoelectric Clamps [38]	Non-invasive, accuracy is 96.07% and has four detection modes- no flow, hot, cold, and mixed.	Doesn't measure water consumption.
4.	Ultrasonic sensor [40]	Non-invasive, high accuracy.	Affected by deposition around the pipe and lacks communication with the service provider.
5.	IR and Laser Sensor [41]	Contactless, high accuracy.	High cost, hardware requirements, and lack of communication with users and service providers.
6.	YF-S201 Water Flow Sensor [42]	Water leakage detection, emailing of usage data to the user.	No communication with the service providers, mailing technology, or Email is still unfamiliar to many individuals.
7.	Self-Powered Water Meter [43]	Water flow harvester.	Either works as an energy harvester or water flow meter, but not both.
8.	Self-Powered Water Meter [44]	Water turbine generator.	Bluetooth transceiver has a short communication range.

the system, warns users of overloading, and warns service providers of energy theft, a few of which were lacking in the existing water and energy meters. Table 9 highlights the major differences between conventional meter readings and automatic meter readings.

Digital energy meters have taken the role of electromechanical induction energy meters, but the users do not gain

from them; they only make reading easier for the billing person. They still lack the capacity to operate remotely, communicate with the service provider, identify power theft, and warn users of overload. Digital energy meters have a conventional billing mechanism prone to human mistakes. The smart energy meter is the remedy to these flaws in the current system. Although each water and energy meter is

TABLE 7. Comparison of existing smart energy meters.

Sl. No.	Meter Type	Highlights	Disadvantages
1.	PIC Microcontroller-Based Smart Energy Meter [57]	Provides constant output voltage along with monitoring the energy consumption.	No communication with the service provider and no overload detection.
2.	IoT Based Smart Energy Meter [58]	Generates bill for the energy consumed and alerts message if the energy consumed crosses the threshold.	No alert for overload and power theft, and lack of communication with the service provider.
3.	Smart Energy Meter Based on IoT and Neural Networks [59]	Communicates the consumed to both service provider and consumer.	Lacks features like remote connection and disconnection, and overload alert.
4.	IoT Based Smart Energy Meter [60]	Real-time monitoring of energy consumption.	Lacks features like overload alert, communication with the service provider and remote connection, and disconnection of electricity.

TABLE 8. Highlights of the proposed integrated system.

Sl. No.	Meter Type	Highlights	Disadvantages
1.	Proposed Integrated Smart Water Meter and Smart Energy Meter	Easy installation, solar-powered smart water meter, real-time monitoring, communication with consumer and service provider, remote reconnection and disconnection, overload alert, and power theft detection.	Requires calibration for change in water pipe dimension.



(a)



(b)

FIGURE 18. Data displayed on 7" TFT display: (a) Showing the real-time data of all the required parameters of the integrated system and (b) Alert message of water supply disconnection.



(a)



(b)

FIGURE 19. Data displayed on 7" TFT display: (a) Alert message of electricity disconnection and (b) Alert message of power overload.

being worked on separately, there isn't enough research to back up the water-energy nexus system.

The smart energy and water meters available are mainly of two types: firstly, the consumption data are recorded and stored in the memory. Secondly, the smart meters employing communication modules for wireless transmission are network-based (GSM-based). The smart meters that employ memory for data storage require labor to access the data and

generate the bill. The network-based smart meters will not be effective if the signal is patchy. Employing communication networks like Bluetooth and Zigbee reduces the communication range, and usage of Wi-Fi can become expensive for the user. The unified system proposed in the paper combines the metering of both water and energy. It employs the LoRaWAN standard for real-time communication that covers indoor and outdoor environments, covering 5 km. Thus, the system is

TABLE 9. Comparison of traditional meter reading with the automatic meter reading.

Sl. No.	Parameters	Traditional Meter Reading	Smart Meters
1.	Stability	Not stable as the data is read at different intervals of time	Time intervals can be customized for each meter based on user needs
2.	Control functionalities	None	Yes
3.	Scalability	None	The user can place more meters at desired locations, and additional features can be integrated, such as temperature readings, etc.
4.	Alarming/alerting capability	None	Yes
5.	Data collection method	Manual	Automatic
6.	Accuracy	Prone to errors and is less accurate with time	More precise and trustworthy
7.	Billing	Billing delays and differences in the amount charged	Accurate billing is made possible by real-time data.
8.	User involvement	Minimal consumer engagement opportunities	Provides users with the ability to monitor usage statistics and identify inefficiencies

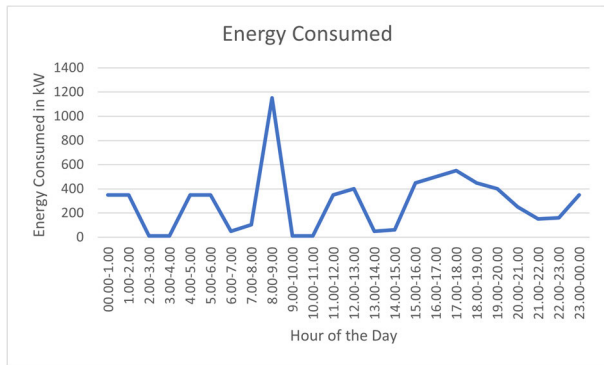

(a)

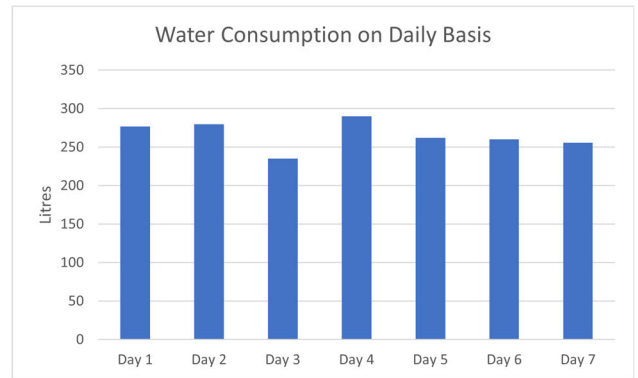
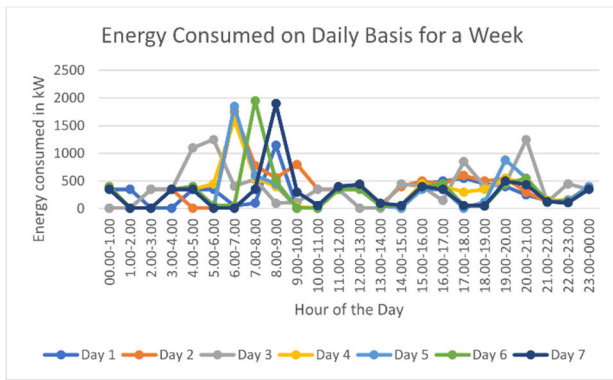

FIGURE 21. Data displayed on 7" TFT display: (a) Showing the real-time data of all the required parameters of the integrated system, (b) Alert message of water supply disconnection, (c) Alert message of electricity disconnection, and (d) Alert message of power overload.



(b)

FIGURE 20. Energy consumption data measured by smart energy meter: (a) Energy consumption for one day and (b) Energy consumption for a week.

not cellular network dependent. Most importantly, the system setup also offers remote control of the meters, which is lacking in existing meters. Another added feature of the system is that the smart water meter uses solar power to power the systems, thus reducing energy consumption.

The limitation of the proposed unified system is at the implementation level, as the traditional meters currently deployed need to be completely replaced with smart meters. The work is further enhanced by integrating the system into

the smart pole for further communication and IoT technology for seamless communication.

V. CONCLUSION

The integrated solution proposed in this research offers functions such as remote power and water shutoff, water and power reconnection, disconnection alert, power theft alert, and overloading alert, making the system unique among those already available. The integrated system highlights unique features with improved functionality, effective integration, and flexibility. The platform has enhanced sensing and communication, increasing the system's suitability for real-time deployment. Using the LoRa communication protocol, a cost-effective solution is implemented to seamlessly operate the integrated water and energy meter. The water flow and energy consumption data are wirelessly transmitted through LoRa. The integrated meter deployed has been shown to offer long-range communication up to 5 kilometers. The integrated system successfully monitors a home's water and energy usage, making it suitable for smart city applications. In addition, the monitoring system aids users in identifying and resolving unusual energy and water consumption. The

unified system proposed is implemented for a single user in the current scenario and will be experimented on two users in further study. The research will be extended for experimentation with multiple users in the future.

REFERENCES

- [1] S. Joshi, S. Saxena, T. Godbole, and Shreya, "Developing smart cities: An integrated framework," *Proc. Comput. Sci.*, vol. 93, pp. 902–909, Jan. 2016, doi: [10.1016/j.procs.2016.07.258](https://doi.org/10.1016/j.procs.2016.07.258).
- [2] V. Yilmaz and C. Telsac, "Smart city components," in *Proc. Int. Conf. Social Sci.*, 2021, pp. 259–266. [Online]. Available: <http://www.researchgate.net/figure/The-Smart-city>
- [3] UNESCO. Accessed: Aug. 24, 2022. *Leaving no One behind: The United Nations World Water Development Report 2019*. [Online]. Available: <https://en.unesco.org/themes/water-security/wwap/wwdr/2019>
- [4] T. AL-Washali, S. Sharma, R. Lupoja, F. AL-Nozaily, M. Haidera, and M. Kennedy, "Assessment of water losses in distribution networks: Methods, applications, uncertainties and implications in intermittent supply," *Resour. Conservation Recycling*, vol. 152, Jan. 2020, Art. no. 104515, doi: [10.1016/j.resconrec.2019.104515](https://doi.org/10.1016/j.resconrec.2019.104515).
- [5] H. Saghi and A. A. Aval, "Effective factors in causing leakage in water supply systems and urban water distribution networks," *Amer. J. Civil Eng.*, vol. 3, nos. 2–2, pp. 60–63, 2015, doi: [10.11648/j.ajce.s.2015030202.22](https://doi.org/10.11648/j.ajce.s.2015030202.22).
- [6] R. Ferroukhi, D. Nagpal, A. Lopez-Peña, T. Hodges, R. H. Mohtar, B. Daher, S. Mohtar, and M. Keulertz, "Renewable energy in the water, energy and food Nexus," in *Proc. Int. Renew. Energy Agency*, Abu Dhabi, United Arab Emirates, 2015, pp. 1–125. [Online]. Available: <https://www.irena.org>
- [7] P. H. Gleick, "Basic water requirements for human activities: Meeting basic needs," *Water Int.*, vol. 21, no. 2, pp. 83–92, Jun. 1996, doi: [10.1080/02508069608686494](https://doi.org/10.1080/02508069608686494).
- [8] A. S. Vieira and E. Ghisi, "Water–energy Nexus in houses in Brazil: Comparing rainwater and gray water use with a centralized system," *Water Supply*, vol. 16, no. 2, pp. 274–283, Apr. 2016, doi: [10.2166/ws.2015.137](https://doi.org/10.2166/ws.2015.137).
- [9] S. Palaniappan, R. Asokan, S. Bharathwaj, and N. Sujaudeen, "Automated meter reading system—A study," *Int. J. Comput. Appl.*, vol. 116, no. 18, pp. 39–46, Apr. 2015, doi: [10.5120/20440-2783](https://doi.org/10.5120/20440-2783).
- [10] N. A. Mat Tahir and S. A. M. Al Junid, "Design of an automatic meter reading (AMR) data logger with Xbee," *Int. J. Simul. Syst. Sci. Technol.*, vol. 13, no. 1, pp. 67–73, Feb. 2012, doi: [10.5013/ijsst.a.13.01.11](https://doi.org/10.5013/ijsst.a.13.01.11).
- [11] C. Palanichamy, N. S. Babu, R. K. Chelvan, and C. Nadarajan, "Restructuring the Indian power sector with energy conservation as the motive for economic and environmental benefits," *IEEE Trans. Energy Convers.*, vol. 14, no. 4, pp. 1589–1596, Dec. 1999, doi: [10.1109/60.815110](https://doi.org/10.1109/60.815110).
- [12] S. Kumar, "Energy and water monitoring system for smart metering and consumer awareness," in *Proc. 2nd Int. Electron. Conf. Sensors Appl.*, Nov. 2015, pp. 1–6, doi: [10.3390/ecsaa-2-e001](https://doi.org/10.3390/ecsaa-2-e001).
- [13] A. Vaidheeswaran. (2016). *Smart Meters and The Barriers it Faces in India*. Accessed: Aug. 28, 2022. [Online]. Available: <https://www.linkedin.com/pulse/smart-meters-barriers-faces-india-archana-iyer>
- [14] V. C. Gungor, D. Sahin, T. Kocak, S. Ergut, C. Buccella, C. Cecati, and G. P. Hancke, "Smart grid technologies: Communication technologies and standards," *IEEE Trans. Ind. Informat.*, vol. 7, no. 4, pp. 529–539, Nov. 2011, doi: [10.1109/TII.2011.2166794](https://doi.org/10.1109/TII.2011.2166794).
- [15] V. C. Gungor, D. Sahin, T. Kocak, S. Ergut, C. Buccella, C. Cecati, and G. P. Hancke, "A survey on smart grid potential applications and communication requirements," *IEEE Trans. Ind. Informat.*, vol. 9, no. 1, pp. 28–42, Feb. 2013, doi: [10.1109/TII.2012.2218253](https://doi.org/10.1109/TII.2012.2218253).
- [16] J.-P. Bardyn, T. Melly, O. Seller, and N. Sornin, "IoT: The era of LPWAN is starting now," in *Proc. 42nd Eur. Solid-State Circuits Conf. (ESSCIRC)*, Sep. 2016, pp. 25–30, doi: [10.1109/ESSCIRC.2016.7598235](https://doi.org/10.1109/ESSCIRC.2016.7598235).
- [17] G. Margelis, R. Piechocki, D. Kaleshi, and P. Thomas, "Low throughput networks for the IoT: Lessons learned from industrial implementations," in *Proc. IEEE 2nd World Forum Internet Things (WF-IoT)*, Dec. 2015, pp. 181–186, doi: [10.1109/WF-IoT.2015.7389049](https://doi.org/10.1109/WF-IoT.2015.7389049).
- [18] N. Sornin, M. Luis, T. Eirich, T. Kramp, and O. Hersent. *LoRaWAN Specification*. Accessed: Sep. 10, 2022. [Online]. Available: https://loralliance.org/resource_hub/lorawan-specification-v1-0-1/
- [19] (2016). *Orange Goes LoRa to Connect French Smart Cities*. Accessed: Sep. 10, 2022. [Online]. Available: <https://readwrite.com/orange-picks-lora-protocol-smart-city-france-pt4/>
- [20] *Regional Parameters | The Things Network*. Accessed: Sep. 10, 2022. [Online]. Available: <https://www.thethingsnetwork.org/docs/lorawan/regional-parameters/>
- [21] *Security | The Things Network*. Accessed: Sep. 10, 2022. [Online]. Available: <https://www.thethingsnetwork.org/docs/lorawan/security/>
- [22] P. N. Srinivasu, R. Panigrahi, A. Singh, and A. K. Bhoi, "Probabilistic buckshot-driven cluster head identification and accumulative data encryption in WSN," *J. Circuits, Syst. Comput.*, vol. 31, no. 17, p. 17, Nov. 2022, doi: [10.1142/s0218126622503030](https://doi.org/10.1142/s0218126622503030).
- [23] J. Kauranen. (2021). *Choosing Right Wireless Network for IoT Devices*. Accessed: Sep. 12, 2022. [Online]. Available: <https://bit.ly/3Jt3Lvr>
- [24] E. Zanaaj, G. Caso, L. D. Nardis, A. Mohammadpour, Ö. Alay, and M.-G. D. Benedetto, "Energy efficiency in short and wide-area IoT technologies—A survey," *Technologies*, vol. 9, no. 1, p. 52, 2021, doi: [10.3390/technologies9010022](https://doi.org/10.3390/technologies9010022).
- [25] *Support—01-Radio Management Configuration-H3C*. Accessed: Sep. 14, 2022. [Online]. Available: http://www.h3c.com/en/d_202012/1371323_294551_0.htm
- [26] R. A. Stewart, R. Willis, D. Giurco, K. Panuwatwanich, and G. Capati, "Web-based knowledge management system: Linking smart metering to the future of urban water planning," *Austral. Planner*, vol. 47, no. 2, pp. 66–74, Jun. 2010, doi: [10.1080/07293681003767769](https://doi.org/10.1080/07293681003767769).
- [27] N. Sushma, H. N. Suresh, and J. M. Lakshmi, "Smart water flow meter for improved measurement of water usage in a smart city," in *Proc. 2nd Int. Conf. Adv. Electr., Comput., Commun. Sustain. Technol. (ICAECT)*, Apr. 2022, pp. 1–6, doi: [10.1109/ICAECT54875.2022.9808041](https://doi.org/10.1109/ICAECT54875.2022.9808041).
- [28] Y.-W. Lee, S. Eun, and S.-H. Oh, "Wireless digital water meter with low power consumption for automatic meter reading," in *Proc. Int. Conf. Conver. Hybrid Inf. Technol.*, 2008, pp. 639–645, doi: [10.1109/ichit.2008.172](https://doi.org/10.1109/ichit.2008.172).
- [29] J. Sun, G. Han, Z. Zeng, and Y. Wang, "Memristor-based neural network circuit of full-function Pavlov associative memory with time delay and variable learning rate," *IEEE Trans. Cybern.*, vol. 50, no. 7, pp. 2935–2945, Jul. 2020, doi: [10.1109/TCYB.2019.2951520](https://doi.org/10.1109/TCYB.2019.2951520).
- [30] J. Sun, Y. Wang, P. Liu, and S. Wen, "Memristor-based circuit design of PAD emotional space and its application in mood congruity," *IEEE Internet Things J.*, early access, Apr. 18, 2023, doi: [10.1109/JIOT.2023.3267778](https://doi.org/10.1109/JIOT.2023.3267778).
- [31] J. Sun, Y. Wang, P. Liu, S. Wen, and Y. Wang, "Memristor-based neural network circuit with multimode generalization and differentiation on Pavlov associative memory," *IEEE Trans. Cybern.*, vol. 53, no. 5, pp. 3351–3362, May 2023, doi: [10.1109/TCYB.2022.3200751](https://doi.org/10.1109/TCYB.2022.3200751).
- [32] B. Chen, Y. Zhou, T. Huang, S. Ying, and T. Chen, "Technical features and application of electromagnetic flow meter," in *Proc. Int. Conf. Commun., Inf. Syst. Comput. Eng. (CISCE)*, Jul. 2020, pp. 1–5, doi: [10.1109/CISCE50729.2020.00008](https://doi.org/10.1109/CISCE50729.2020.00008).
- [33] B. S. Buck, M. C. Johnson, and S. L. Barfuss, "Effects of particulates on water meter accuracy through expected life," *J. Amer. Water Works Assoc.*, vol. 104, no. 4, pp. 231–242, 2012, doi: [10.5942/jawwa.2012.104.0054](https://doi.org/10.5942/jawwa.2012.104.0054).
- [34] K. Kumar, T. K. Swain, C. S. Ekhande, and R. M. Nanaware, "Effects of flow measurement on sloped pipes using ultrasonic flowmeter," in *Proc. Int. Conf. Ind. Instrum. Control (ICIC)*, May 2015, pp. 1490–1494, doi: [10.1109/IIC.2015.7150985](https://doi.org/10.1109/IIC.2015.7150985).
- [35] D. W. Spitzer. *Flowmeters Defined|Water & Wastes Digest*. Accessed: Sep. 21, 2022. [Online]. Available: <https://www.wwdmag.com/metering/meters-flow/article/10918670/flowmeters-defined>
- [36] S. Botha, L. Meijssen, G. Hancke, and B. Silva, "Design of a water flow and usage meter," in *Proc. 42nd Annu. Conf. IEEE Ind. Electron. Soc. (IECON)*, Oct. 2016, pp. 6211–6215, doi: [10.1109/IECON.2016.7793724](https://doi.org/10.1109/IECON.2016.7793724).
- [37] G. Gosavi, G. Gawde, and G. Gosavi, "Smart water flow monitoring and forecasting system," in *Proc. 2nd IEEE Int. Conf. Recent Trends Electron., Inf. Commun. Technol. (RTEICT)*, May 2017, pp. 1218–1222, doi: [10.1109/RTEICT.2017.8256792](https://doi.org/10.1109/RTEICT.2017.8256792).
- [38] A. Vafeas, A. Elsts, J. Pope, X. Fafoutis, G. Oikonomou, R. Piechocki, and I. Craddock, "Energy-efficient, noninvasive water flow sensor," in *Proc. IEEE Int. Conf. Smart Comput. (SMARTCOMP)*, Jun. 2018, pp. 139–146, doi: [10.1109/SMARTCOMP.2018.00084](https://doi.org/10.1109/SMARTCOMP.2018.00084).
- [39] S.-C. Hsia, Y.-J. Chang, and S.-W. Hsu, "Remote monitoring and smart sensing for water meter system and leakage detection," *IET Wireless Sensor Syst.*, vol. 2, no. 4, pp. 402–408, Dec. 2012, doi: [10.1049/iet-wss.2012.0062](https://doi.org/10.1049/iet-wss.2012.0062).

- [40] V. Gaikwad, Y. Bagul, A. Sarap, and S. Swami, "IoT based smart flow meter for smart cities," in *Proc. IEEE Pune Sect. Int. Conf. (PuneCon)*, Dec. 2020, pp. 138–141, doi: [10.1109/PuneCon50868.2020.9362468](https://doi.org/10.1109/PuneCon50868.2020.9362468).
- [41] P. M. Bansode and V. B. Kulkarni, "IR and LASER sensors for Newtonian fluids for flow-rate measurement using FPGA," in *Proc. Int. Conf. Ind. Instrum. Control (ICIC)*, May 2015, pp. 821–824, doi: [10.1109/IIIC.2015.7150855](https://doi.org/10.1109/IIIC.2015.7150855).
- [42] F. Ali and M. F. H. Saidi, "Water leakage detection based on automatic meter reading," in *Proc. 15th Int. Conf. Ubiquitous Inf. Manage. Commun. (IMCOM)*, Jan. 2021, pp. 1–7, doi: [10.1109/IMCOM51814.2021.9377437](https://doi.org/10.1109/IMCOM51814.2021.9377437).
- [43] J. S. Alrowaijeh and M. R. Hajj, "Autonomous self-powered water meter," *Appl. Phys. Lett.*, vol. 113, no. 3, Jul. 2018, doi: [10.1063/1.5040712](https://doi.org/10.1063/1.5040712).
- [44] X. J. Li and P. H. J. Chong, "Design and implementation of a self-powered smart water meter," *Sensors*, vol. 19, no. 19, p. 4177, Sep. 2019, doi: [10.3390/s19194177](https://doi.org/10.3390/s19194177).
- [45] S. S. S. R. Depuru, L. Wang, V. Devabhaktuni, and N. Gudi, "Smart meters for power grid—Challenges, issues, advantages and status," in *Proc. IEEE/PES Power Syst. Conf. Expo.*, Mar. 2011, pp. 1–7, doi: [10.1109/PSCE.2011.5772451](https://doi.org/10.1109/PSCE.2011.5772451).
- [46] A. Tiwary and M. K. Chandrol, "A comprehensive review of smart energy meters: An innovative approach," *Int. J. Future Revolution Comput. Sci., Commun. Eng.*, vol. 4, no. 4, pp. 239–243, 2018. [Online]. Available: <http://www.ijfrcsce.org>
- [47] N. C. Jaramillo, C. Jaime, F. Cardona, J. David, and V. Henao, "Smart meters adoption: Recent advances and future trends," *Dyna*, vol. 81, no. 183, pp. 221–230, 2014, doi: [10.15446/dyna.v18n183.38148](https://doi.org/10.15446/dyna.v18n183.38148).
- [48] V. Devaliya, A. Chauhan, F. Faldu, K. Mishra, and S. Choubey, "Literature review on smart energy meter," *Int. J. Innov. Res. Sci., Eng. Technol.*, vol. 7, no. 12, pp. 12001–12003, 2018.
- [49] M. U. Patel and M. M. Modi, "A review on smart meter system," *Int. J. Innov. Res. Electr., Electron., Instrum. Control Eng.*, vol. 3, no. 12, pp. 70–73, 2015, doi: [10.17148/ijireice.2015.31215](https://doi.org/10.17148/ijireice.2015.31215).
- [50] B. D. Sawarkar and M. S. S. Golait, "A review paper on automatic meter reading and instant billing," *IJARCCCE*, vol. 4, no. 1, pp. 213–217, Jan. 2015, doi: [10.17148/ijarccce.2015.4146](https://doi.org/10.17148/ijarccce.2015.4146).
- [51] S. Araya and N. Rakesh, "Review on design of residential IoT based smart energy meters," *Int. Res. J. Eng. Technol.*, vol. 6, no. 7, pp. 30–3018, 2019. [Online]. Available: <http://www.irjet.net>
- [52] S. Hassan Mir, "Review on smart electric metering system based on GSM/IoT," *Asian J. Electr. Sci.*, vol. 8, no. 1, pp. 1–6, Feb. 2019. [Online]. Available: <https://www.trp.org.in/issues/review-on-smart-electric-metering-system-based-on-gsm-iot>
- [53] L. Ajit and Y. Bhute, "A review on IoT based smart and multi-functional energy meter," *Int. J. Innov. Res. Comput. Commun. Eng.*, vol. 5, no. 1, pp. 874–878, 2017.
- [54] R. Jain, S. Gupta, C. Mahajan, and A. Chauhan, "IoT based smart energy meter monitoring and controlling system," *Int. J. Res. Electron. Comput. Eng.*, vol. 7, no. 2, pp. 1600–1604, 2019. [Online]. Available: <https://bitelectronicssystem.com/wp-content/uploads/2020/12/IoT-based-Smart-Energy-Meter-Monitoring-and-Controlling-System.pdf>
- [55] R. Khwanrit, S. Kittipiyakul, J. Kudtonagngam, and H. Fujita, "Accuracy comparison of present low-cost current sensors for building energy monitoring," in *Proc. Int. Conf. Embedded Syst. Intell. Technol.*, 2018, pp. 1–6, doi: [10.1109/ICESIT-ICICTES.2018.8442066](https://doi.org/10.1109/ICESIT-ICICTES.2018.8442066).
- [56] *PZEM-004T V3.0 User Manual*, document PZEM-004T, Peacefair, Jun. 2019.
- [57] C. J. Sharma, A. S. Bhajbhujje, N. R. Tajane, and B. V. Dharmik, "Design and implementation of smart energy meter," *Int. J. Res. Appl. Sci. Eng. Technol.*, vol. 10, no. 4, pp. 767–772, 2022, doi: [10.22214/ijraset.2022.41262](https://doi.org/10.22214/ijraset.2022.41262).
- [58] M. Rupesh and N. A. Selvan, "Design of IoT based smart energy meter for home appliances," *J. Phys., Ser.*, vol. 1964, no. 5, 2021, Art. no. 052001, doi: [10.1088/1742-6596/1964/5/052001](https://doi.org/10.1088/1742-6596/1964/5/052001).
- [59] S. Priya, A. Srivastava, S. K. Jindal, and S. K. Sahoo, "Design and implementation of a smart energy meter based on Internet of Things and neural network approach," in *Proc. Int. Conf. Internet Things Connected Technol.*, 2018, pp. 650–657, doi: [10.2139/ssrn.3170196](https://doi.org/10.2139/ssrn.3170196).
- [60] M. Pimple, S. Thopate, A. Nikam, and S. Gadekar, "IoT based smart energy meter using ESP 32," in *Proc. Int. Conf. Commun. Inf. Process.*, pp. 1–5, 2021, doi: [10.2139/ssrn.3917892](https://doi.org/10.2139/ssrn.3917892).



Her research interests include the Internet of Things, smart cities, wireless networks, and cryptography.

N. SUSHMA received the B.E. degree in electronics and communication engineering from the GSSS Institute of Engineering and Technology for Women Mysore, Visvesvaraya Technological University, Hassan, Karnataka, India, in 2011, and the M.Tech. degree in digital electronics and communication systems from the Malnad College of Engineering, Visvesvaraya Technological University, in 2013. She is currently an Assistant Professor with the Malnad College of Engineering.



Electrical and Electronics Engineering, MCE, for three years tenure and served as the Dean (Research) for quite some time. He has successfully guided several researchers and has got important contributions published in Elite international journals. His research interests include solar and wind energy innovations and applications, power electronics applied to drive control, and the IoT applications to smart cities. He is a fellow of The Institution of Engineers, India, and also contributed as a reviewer of prominent international conferences and journals.

H. N. SURESH received the M.E. degree in electrical engineering and the Ph.D. degree from the Indian Institute of Science (IISc), Bengaluru, India, in 1991 and 2000, respectively. His Ph.D. studies computational work titled "Modeling of Inhomogeneous Field Breakdown in SF6 for Lightning Impulse Stress—A Field Approach." He is a retired Professor with the Malnad College of Engineering (MCE), Hassan, India. Before his retirement, he was heading the Department of



in international journals/conferences. Her research interests include power electronics applied to drive control, electric vehicle technology, and the IoT applications for smart cities. She received the Best Project Guide Award for the project titled "Fabrication of Potable Solar Water Purifier," in 2018, and the Best Paper Presenter Award for the research article "Performance Analysis of Five-Level Inverter for Hybrid Distribution Generation System." She has two patents in her name. She is a reviewer member of various international journals and conferences, including IEEE.

J. MOHANA LAKSHMI (Senior Member, IEEE) received the B.E. degree from the P. E. S. College of Engineering, Mandya, in 2010, the M.Tech. degree (Hons.) from the Malnad College of Engineering, Hassan, Karnataka, India, in 2012, and the Ph.D. degree in power electronics and drives, in July 2019. She is currently with the Department of Computer Science and Engineering, Malnad College of Engineering, as an Associate Professor. She has published several research papers



PARVATHANENI NAGA SRINIVASU received the bachelor's degree in computer science engineering from the Sri Sarathi Institute of Engineering and Technology (SSIET), Jawaharlal Nehru Technological University (JNTU), Kakinada, in 2011, and the master's degree in computer science technology and the Ph.D. degree from GITAM University, Visakhapatnam, India, in 2013 and 2020, respectively. His Ph.D. thesis entitled "An Investigative Analysis of Automated

Segmentation Approaches for Volumetric Estimation of Damaged Regions in Astrocytoma Cases Identified from the 2D Brain MR Image." He is currently an Associate Professor with the Department of Computer Science and Engineering, Prasad V. Potluri Siddhartha Institute of Technology, Vijayawada. He has edited books with premier publishers, such as Elsevier, Springer, IGI Global, and Bentham Science. His research interests include biomedical imaging, soft computing, and healthcare informatics. Throughout the course of research, he has published extensively in high-quality outlets, including peer-reviewed journals.



AKASH KUMAR BHOI (Member, IEEE) received the B.Tech., M.Tech., and Ph.D. degrees. He was appointed as the honorary title of "Adjunct Fellow" with the Institute for Sustainable Industries and Liveable Cities (ISILC), Victoria University, Melbourne, Australia, from August 2021 to July 2022. He was also the University Ph.D. Course Coordinator for research and publication ethics (RPE) with Sikkim Manipal University (SMU). He is currently an Adjunct Faculty with the KIET Group of Institutions, India, and an Adjunct Research Faculty with

the Directorate of Research, SMU. He is also a Research Associate with the Wireless Networks (WN) Research Laboratory, Institute of Information Science and Technologies, National Research Council (ISTI-CRN), Pisa, Italy, and a former Assistant Professor (SG) with the Sikkim Manipal Institute of Technology and served for about ten years. He is currently editing several books with Springer Nature, Elsevier, and Routledge & CRC Press. He has published several papers in national and international journals and conferences and more than 150 publications registered in the Scopus database. His research interests include biomedical technologies, the Internet of Things, computational intelligence, antenna, and renewable energy. He is a member of ISEIS and IAENG, an Associate Member of IEI and UACEE, and an editorial board member reviewer of Indian and international journals. He is also a regular reviewer of reputed journals, namely IEEE, Springer, Elsevier, Taylor and Francis, and Inderscience. He has served on numerous organizing panels for international conferences and workshops. He is serving as the guest editor for special issues of journals, such as Springer Nature, Wiley | Hindawi, and Inderscience. He is listed in the World's Top 2% Scientists for single-year impact for the year 2022 (compiled by John P. A. Ioannidis, Stanford University, and published by Elsevier BV).



PAOLO BARSOCCHI received the M.Sc. and Ph.D. degrees in information engineering from the University of Pisa, Italy, in 2003 and 2007, respectively. He is currently a Researcher with the Institute of Information Science and Technologies, National Research Council, Pisa. He has co-authored more than 100 articles published in international journals and conference proceedings. His research interests include the IoT, cyber-physical systems, indoor localization, and systems monitoring.

He is a member of numerous program committees and editorial board of international journals, and the program chair and the co-chair of several conferences.

...

Open Access funding provided by 'Consiglio Nazionale delle Ricerche-CARI-CARE-ITALY' within the CRUI CARE Agreement