

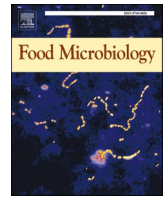

Contents lists available at ScienceDirect

Food Microbiology

journal homepage: www.elsevier.com/locate/fm

Leuconostoc performance in soy-based fermentations – Survival, acidification, sugar metabolism, and flavor comparisons

Anders Peter Wätjen^a, Luciana De Vero^b, Estefania Núñez Carmona^c, Veronica Sberveglieri^{c,d}, Wenkang Huang^e, Mark S. Turner^e, Claus Heiner Bang-Berthelsen^{a,*}

^a National Food Institute, Technical University of Denmark, 2800, Kgs. Lyngby, Denmark

^b Department of Life Sciences, University of Modena and Reggio Emilia, 42122, Reggio Emilia, Italy

^c National Research Council, Institute of Bioscience and Bioresources (CNR-IBBR), Via J.F. Kennedy, 17/i, 42124, Reggio Emilia, Italy

^d Nano Sensor Systems, NASYS Spin-Off University of Brescia, 25125, Brescia, Italy

^e School of Agriculture and Food Sciences, University of Queensland, Brisbane, Queensland, Australia

ARTICLE INFO

Keywords:

Lyophilization
Cheese analogues
Volatilome
Soy fermentation
Leuconostoc
Plant-based alternatives

ABSTRACT

Leuconostoc spp. is often regarded as the flavor producer, responsible for the production of acetoin and diacetyl in dairy cheese. In this study, we investigate seven plant-derived *Leuconostoc* strains, covering four species, in their potential as a lyophilized starter culture for flavor production in fermented soy-based cheese alternatives. We show that the process of lyophilization of *Leuconostoc* can be feasible using a soy-based lyoprotectant, with survivability up to 63% during long term storage. Furthermore, the storage in this media improves the subsequent growth in a soy-based substrate in a strain specific manner. The utilization of individual raffinose family oligosaccharides was strain dependent, with *Leuconostoc pseudomesenteroides* NFICC99 being the best consumer. Furthermore, we show that all investigated strains were able to produce a range of volatile flavor compounds found in dairy cheese products, as well as remove certain dairy off-flavors from the soy-based substrate like hexanal and 2-pentylfuran. Also here, NFICC99 was strain producing most cheese-related volatile flavor compounds, followed by *Leuconostoc mesenteroides* NFICC319. These findings provide initial insights into the development of *Leuconostoc* as a potential starter culture for plant-based dairy alternatives, as well as a promising approach for generation of stable, lyophilized cultures.

1. Introduction

Global food trends show a growing interest in plant-based alternatives and a shift away from animal-based products (Zioga et al., 2022). Even so, the selection of commercial cheese- and dairy alternatives often lack flavor, texture, and nutritional value, and is often comprised of a range of ingredients (Huang et al., 2022). This is opposed to yoghurt and cheese, which often just comprise milk and bacterial cultures. The flavor profile of dairy cheese is, in large part, impacted by the fermentation products formed by the microorganisms used. Most dairy starter cultures have been optimized in milk to a point where they are either poor or incapable of growing on other substrates (Steensels et al., 2019). Hence, plant-based dairy alternatives are rarely fermented, which in turn necessitates long ingredient lists to account for flavor and texture. Searching for novel bacterial strains in the plant realm could pave a new road for fermented dairy alternatives.

Leuconostoc spp. are regarded as non-starter lactic acid bacteria (NSLAB) in cheese making, but are also often found on vegetable in fermented foods (Shin and Han, 2015). They are often intentionally added to improve flavor and texture of the product (Pedersen et al., 2013), but also appear as spontaneous part of the microbiota in dairy fermentations (Hemme and Foucaud-Scheunemann, 2004; Vedamuthu, 1994). They are heterofermentative, facultative anaerobic bacteria, which are involved in citrate metabolism in cheese where citrate is converted to important dairy flavors (Özcan et al., 2019). The ability to metabolize citrate by different *Leuconostoc* species has been investigated several times (Kihal et al., 1996; Lin et al., 1991; Vaughan et al., 1995). Until recently, it was thought to be linked to a ~22 kb plasmid and seemed to be solely present in dairy-related strains. However, a recent genomic study found that in *Ln. cremoris* and *Ln. pseudomesenteroides* it was linked to a chromosomally located operon, though still only present in dairy-associated strains (Frantzen et al., 2017). Accordingly,

* Corresponding author.

E-mail address: claban@food.dtu.dk (C.H. Bang-Berthelsen).

<https://doi.org/10.1016/j.fm.2023.104337>

Received 19 May 2023; Received in revised form 6 July 2023; Accepted 10 July 2023

Available online 14 July 2023

0740-0020/© 2023 The Authors. Published by Elsevier Ltd. This is an open access article under the CC BY license (<http://creativecommons.org/licenses/by/4.0/>).

Leuconostoc spp. strains could potentially be used for the development of fermented dairy alternatives.

The production and storage of stable starter cultures is another important factor to consider, in the process of fermented dairy alternatives. Oftentimes, these cultures are lyophilized bacteria in a matrix of skimmed milk. To truly stay plant-based, this matrix ought to be replaced, preferably using the same plant base as the end product. This would both help end users with allergies or specific dietary requirements and keep the ingredient list simple. The use of alternative lyoprotectants has previously proven capable of protecting lactic acid bacteria (LAB) and other bacteria (Choi et al., 2020; Mahidsanan et al., 2017; Quintana et al., 2017). But the research on lyophilization of the specific LAB genus *Leuconostoc*, in general, is limited, and there is no work on utilizing soy as a lyoprotectants for this genus. Soy as a substrate is interesting in several ways. It is a crop that has many similarities to milk, making it a good starting point for developing dairy alternatives. Soy-based milk alternatives have protein levels and amino acid composition comparable to that of milk (Barraquio and van de Voort, 1988; Walther et al., 2022). Additionally, the major protein groups are globular, whey-like proteins, making them suitable for the production of yoghurt alternatives. Lastly, high citrate levels in soy enable the option for important dairy flavors, such as acetoin and diacetyl, often produced in cheese by *Leuconostoc*.

In this study, we explored plant-associated *Leuconostoc* strains, which can metabolize citrate and grow in a soy-based medium. These features will be important when developing fermented dairy alternatives, as the metabolism of both citrate and whey-like proteins can be precursors for dairy flavor development. Further, we propose a soy-based method of lyophilizing *Leuconostoc* cultures, and investigate the metabolic profile and volatolome of the isolated strains. We screened seven candidate strains, ranging from four different *Leuconostoc* species for their ability to survive lyophilization in a soy flour-based medium. Then, the impact of the process on acidification and flavor formation was assessed through pH monitoring, High-performance liquid chromatography (HPLC) and Headspace solid-phase microextraction (HS-SPME) coupled with gas chromatography–mass spectrometry (GC-MS). The results presented here provide a useful basis for further elucidating the potential of *Leuconostoc* spp. as starter cultures for dairy alternatives.

2. Materials and methods

2.1. Bacterial isolation and candidate selection

All strains investigated were isolated from either wild plants or homemade sourdough cultures from Denmark. Briefly, strains were isolated in the following manner: samples were mixed with De Man, Rogosa and Sharpe (MRS) broth (Oxoid LTD, UK), and incubated at 30 °C for 24 h. Then, 50 µL overnight culture was spread on MRS agar plates, which were left aerobic at 30 °C for 2 days. Single colonies were then picked and streaked twice to obtain pure cultures. The pure strains were then identified using a MALDI-TOF Biotyper® sirius one RUO system (Bruker, US). After strains identification, a copy of them was cryopreserved at –80 °C and deposited in the National Food Institute Culture Collection (NFICC) at the Technical University of Denmark. Strains belonging to the genus *Leuconostoc* were tested for their ability to acidify and create curd in a soy flour medium (SFM). Seven strains were chosen to be tested as possible starter cultures for the production of cheese flavors in SFM.

SFM was produced by adding 50 g of soy flour type I (Sigma-Aldrich, US) in 1 L MilliQ H₂O. This was stirred for 1 h, after which the medium was centrifuged at 1000×g for 3 min. The supernatant was collected, pH adjusted to 6.5 with 1M HCl or 1M NaOH, and then autoclaved at 121 °C for 15 min.

2.2. Species assignment and genotyping

The strains were identified using a MALDI-TOF Biotyper® sirius one

RUO system (Bruker, US), with the BDAL reference library. Additionally, whole genome sequencing (WGS) was performed on the seven strains investigated in this study to link phenotypical traits to a genotype.

2.2.1. DNA extraction and sequencing

DNA extraction was performed using DNeasy Blood and Tissue kit (Qiagen, US), following the manufacturer's procedure. WGS was then performed by paired-end libraries using Illumina NextSeq 500 by Novozymes A/S. All reads had automatic adaptor removal and low-quality bases trimmed by Trimmomatic version 0.33.

2.2.2. Trimming and de novo assembly

Trimming was done by bbduk2, where bases at the end of the read with a Phred score below 20 were removed. Furthermore, short reads with a length below 50 base pairs and adaptors were removed. FastQC was used to assess the quality of sequencing. Samples with less than 500,000 reads and samples with lower than 50% of percent quality bases after trimming were discarded for further analysis.

The reads of each sample were *de novo* assembled by SPAdes using multiple values of k (21, 33, 55, 77, and 99) optimized for Illumina reads to reduce the number of mismatches and short indels, and coverage cutoff option of 2.0. Contigs below 500 base pairs were excluded. QUAST version 4.5 was used to check assembly metrics (Gurevich et al., 2013). Samples with an N50 less than 50,000 and samples with the number of contigs higher than 150 were discarded for further analysis.

2.2.3. Gene annotation

Subsequent gene annotation was performed in CLC workbench v.8.0, specifically utilizing the BLAST and pfam analysis tool for gene homology search and verification of gene function respectively.

2.3. Lyophilization process and survival rate

2.3.1. Lyophilization

A preculture of each strain was grown on MRS plates for two days at 30 °C until growth completely covered the plate. Cultures were harvested from plates using a 10 µL plastic loop and resuspended in the lyophilization medium, which was a 1:1 mix of either MRS:10% skim milk (SM) (both from Oxoid, UK) solution or soyMRS:SFM (see formulation below). A dilution of the inoculated lyophilization media was spread on MRS plates to calculate the initial inoculum before lyophilization. An aliquot (500 µL) of the strain suspensions was transferred into glass ampules (Vacule®, WHEATON®, DWK Life Sciences, Germany) and, successively, a cotton plug (about 20 mg by weight) was inserted up to the first narrowing of the ampule to avoid contamination during the process. Additionally, a butane rubber cap was put on the top without closing the ampules. Before lyophilization, the prepared ampules were kept for 1 h at 4 °C, then 2 h at –80 °C. Then they were placed in a Lio 5P freeze dryer (5 Pa, Italy), which ran on default settings (–40 °C, <0.2 mbar) for 18 h, after which the ampules were completely closed by using the stoppering system of the freeze dryer. Finally, each glass ampule was sealed using a flame to ensure the vacuum inside during long-term storage. Ampules were used immediately to check strain viability or kept at 37 °C for 7 days to simulate 10 years of storage at room temperature (Peiren et al., 2016; Takeshi and Kuroshima, 1997).

SoyMRS medium was produced as follows: in 1 L of MilliQ H₂O was added 25g of peptone from soybean (Millipore, US), 20g of glucose (Acros Organics, Germany), 5g of sodium acetate trihydrate (Sigma-Aldrich, US), 1g of TWEEN 80 (Sigma-Aldrich, US), 2g dipotassium hydrogen phosphate (Carlo Erba reagents GmbH, Germany), 2g of triammonium citrate (Fluka Chemie GmbH, Germany), 0.2g of magnesium sulfate heptahydrate (Sigma-Aldrich, US), and 50 mg of manganese sulfate tetrahydrate (ThermoFisher Scientific, US). The medium was then adjusted to pH 6.2 using 1M HCl or NaOH, and autoclaved at 121 °C for 15 min.

2.3.2. Survival rate

The survival rate of the lyophilized strains was evaluated immediately after the lyophilization process and after simulated aging at 37 °C. Three ampoules were opened for each time point and the dried culture was resuspended in MRS. The resuspension was then serially diluted and plated on MRS agar plates, incubated aerobically for 48 h at 30 °C, and the CFU was recorded. To estimate the survival rate (in %), the following equation was used:

$$\frac{\text{CFU in ampule}}{\text{CFU before lyophilization}} * 100\%$$

2.4. Acidification in SFM

To assess any changes in primary growth efficiency, the pH development in SFM was tested on strains before and after lyophilization. 10⁹ CFU of either lyophilized cells or an MRS overnight culture (washed twice in 0.9% NaCl) was added to 20 ml SFM in a 50 ml shake flask. The flasks were placed in a 30 °C water bath, and pH was logged every 15 min for 24 h using an iCinac Analyzer (KPM Analytics, United States). All samples were run in technical triplicates.

2.5. Primary metabolism – HPLC

Samples used for analysis of this section (HPLC) and the following (HS SPME-GC-MS) were collected from fermentations in SFM, using the seven candidate strains investigated in this study. Approximately 10⁹ CFU of each strain was inoculated in 100 ml SFM in 250 ml Erlenmeyer flasks, and kept at 30 °C, 200 RPM. 10 ml sample was taken after 18 h and one week.

To measure the levels of sugar, organic acid, ethanol, acetoin, and diacetyl in cultures, an UltiMate 3000 HPLC system (ThermoFischer Scientific, US) was employed. An Aminex HPX-87H column (Bio-Rad, US) was used for the analysis, which was detected by a Shodex RI-101 refractive index detector (Showa Denko K.K., Japan). The mobile phase employed was 5 mM sulfuric acid at a flow rate of 0.5 mL/min, and each sample was run for 30 min. The column temperature was held constant at 60 °C. Samples were diluted 1:1 with 5 mM sulfuric acid, mixed by inversion and vortexing, and then centrifuged at 2400×g for 5 min. The supernatant was filtered through a 0.22 µm syringe filter (Th. Geyer GmbH, Germany) before analysis. Identification and quantification of metabolites were carried out by measuring analytically pure standards in 5 mM H₂SO₄. All samples were run in technical triplicates.

2.6. Secondary metabolism – HS SPME-GC-MS

For volatile compounds analysis, 5 ml sample was transferred into a 20 mL chromatographic vial sealed with Silicon-PTFE septum, crimped with an aluminum crimp, and then subjected to SPME-GC-MS experiment. The volatile components of fermented SFM were extracted and identified by the headspace SPME-GC-MS method. A Shimadzu Gas Chromatograph GC2010 PLUS (Kyoto, KYT, Japan) interfaced with a Shimadzu single quadrupole Mass Spectrometer MS-QP2010 (Kyoto, KYT, Japan) ultra was used to analyze the headspace compounds. All extractions were carried out using a DVB/carboxen/PDMS (divinylbenzene/carboxen/polydimethylsiloxane) stable flex (50/30 m) (Supelco Co. Bellefonte, PA, USA) SPME triphasic fiber. A simultaneous headspace equilibrium and extraction was done by exposing the triphasic fiber for 20 min at 40 °C, approximately 1–2 cm above the sample liquid. Fiber desorption took place in the GC-MS injector for 6 min at 250 °C. GC was operated in direct mode throughout the run. The extracted volatile compounds of the fermented SFM samples were separated by a low-polarity MEGA-5MS capillary column, 25 m × 0.25 mm × 0.25 µm (DB-WAX, Agilent Technologies, Santa Clara, CA, USA). The chromatogram was recorded with the following temperature program:

- 40 °C held for 1 min.
- Linear rise to 50 °C at 4,5 °C/min.
- Linear rise to 80 °C at 6,5°C/min.
- Linear rise to 180 °C at 15 °C/min.
- Linear rise to 240 °C at 45 °C/min.
- 240 °C held for 1 min for thermal desorption of the analytes.

The carrier gas used was hydrogen with a flow rate of 2,43 mL/min produced by GENius PF500, FullTech Instruments Srl (Rome, Italy). During the analysis, the GC-MS interface was kept at 240 °C, with the mass spectrometer in the electron ionization (EI) mode (70 eV) and related to instrument tuning, and the ion source was kept at 240 °C. Mass spectra were collected over 35–500 m/z in range in the total ion current (TIC) mode, with scan intervals at 0.3 s. The eluted compounds were identified by comparing them with the compounds listed in the National Institute of Standards and Technology (NIST) using the NIST11, NIST11S and the FFNSC2 libraries of mass spectra (Núñez-Carmona et al., 2019a, 2019b). Chromatogram peak integration was performed using the peak area as target parameter programming, an automatic integration round using 70 as the minimum number of peak detection, and 500 as the minimum area to detect. Other parameters used in the automatic peak integration were: slope 100/min, width 2 s, drift 0/min, doubling time (T.DBL) 1000 min, and no smoothing method was applied. The final round of peak integration was performed by manual peak integration for all the obtained chromatograms. All samples were run in technical triplicates, and the detection of a compound was deemed reliable if it was present in two of three samples.

2.7. Statistical analysis

For all results concerning viability, acidification, HPLC, and HS SPME GC-MS, the results are averaged values of 3 replica from individual fermentations. For the viability test, the error bars are indicative of standard deviation. The significance of using either of the lyoprotectants for each individual strain were tested, using the Student t.test. Significant results (p < 0.05) were marked with an asterisk. For HS SPME GC-MS results, volatile compounds related to cheese was recorded as being present only when they were present in at least 2 out of 3 samples, and represented in a binary visual table of present/not present.

3. Results and discussion

In the following section, we describe the suitability of seven strains of *Leuconostoc* isolated from plant-based origins, assessing their ability to survive a lyophilization process and their metabolic capabilities when fermenting a soy-based medium. The seven strains covered four different species. One *Leuconostoc citreum* (*Ln citreum*) named NFICC28, one *Leuconostoc lactis* (*Ln lactis*) named NFICC80, one *Leuconostoc pseudomesenteroides* (*Ln pseudomesenteroides*) named NFICC99 and four *Leuconostoc mesenteroides* (*Ln mesenteroides*) named NFICC311, NFICC319, NFICC320, and NFICC321.

3.1. Lyophilization and survival rate

To assess SFM as a possible lyoprotectant, all strains were tested with two different media. One was a 1:1 mix of MRS:SM, a composition regularly used as a lyoprotectant, as a reference. The other was a 1:1 mix of soyMRS:SFM.

After the lyophilization, the strains were protected, and embedded in a porous cake of lyoprotectant. In general, the cake morphology was considered normal for all strains, in both media conditions, showing a compact, intact cake (Fig. 1). This morphology has previously been associated with high levels of survival, as according to Peiren et al. (2016).

The survival rate immediately after lyophilization was above 50% for all strains in both lyoprotectants (Fig. 2), though NFICC99 and



Fig. 1. Example of the final lyophilized cultures. The dried culture cake in the bottom of the ampule is highly protected in a vacuum. The cotton plug in the top was used as an initial barrier to avoid contamination during the lyophilization process.

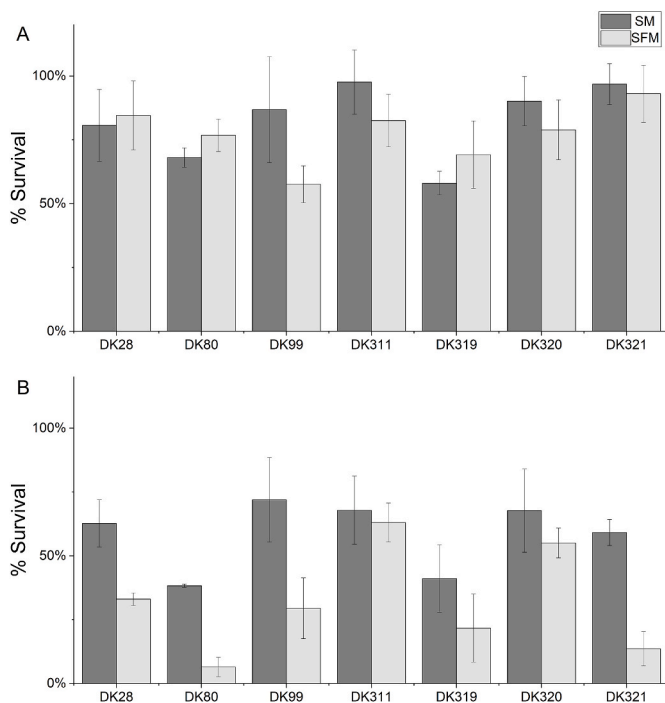

Fig. 2. Survival rate of lyophilized strains. A) Immediately after lyophilization. B) 10 years simulated aging. Error bars indicate standard deviations. $n = 3$. * $p < 0.05$.

NFICC311 showed slightly increased survival in MRS:SM. After the simulated aging, the survival pattern changed in favor of MRS:SM for all strains. Even so, NFICC311 and NFICC320 had survival rates of 63% and 55% in soyMRS:SFM, respectively, after simulated aging. On the other hand, NFICC80 and NFICC321 which both had high survival rates immediately after lyophilization, showed a rate of 6% and 14% respectively in soyMRS:SFM, while retaining more of their viability in the MRS:SM lyoprotectant. These inconsistent changes in viability across the strains – especially for soyMRS:SFM – indicates that a soy-based lyoprotectant might not be suitable universally for all *Leuconostoc* species in terms of viability during storage, but does show promise on a strain specific basis, as seen for NFICC311 and NFICC320.

Other studies have also used soybean material as a lyoprotectant for

other LAB with promising results (Gwak et al., 2015; Wang et al., 2004), but to our knowledge no one has tested this specifically for *Leuconostoc* strains before. For the cultures exposed to simulated aging, there was a higher tendency for high survival with the MRS:SM media composition, which could be caused by various factors. Both lipids, proteins, and carbohydrate composition (Bodzen et al., 2021; Cheng et al., 2022; Day and Stacey, 2007; Jawan et al., 2022), are known to have an effect on the protective nature of lyoprotectants. The soybean flour in this study has a very low lipid content as it is defatted, and so, trials with the addition of vegetable oils could be employed to investigate if viability could be kept at a higher level while keeping the lyoprotectant plant-based. On the other hand, all strains maintained high viability throughout the lyophilization process. It might not be industrially relevant to store a starter culture for ten years, and since the soy-based lyoprotectant here is relatively inexpensive, it might still be a viable option for production.

3.2. Acidification in SFM

The pH development in SFM inoculated with the investigated strains was monitored for 24h for all strains in two different conditions (Fig. 3). In one condition, a non-lyophilized overnight culture (NLC) of the strains grown in MRS, in the other condition, an equal amount of CFU was added from a lyophilized culture (LC). The final pH of the individual strain was similar under both conditions, but the rate of acidification was enhanced for NFICC28, NFICC311, NFICC319, NFICC320, and NFICC321 when using a LC. On the other hand, it was largely unchanged for NFICC99 and even slowed down for NFICC80. It can be discussed if the increase in acidification rate could be caused by the acclimatization to the SFM medium, where the cells had been stored. Durica-Mitic et al. (2018) review the intricate regulation of carbohydrate metabolism, and how the present sugars determine the activity of various enzymatic systems in the cell. It could be hypothesized that the necessary enzymatic machinery for e.g. carbohydrate consumption in SFM had been

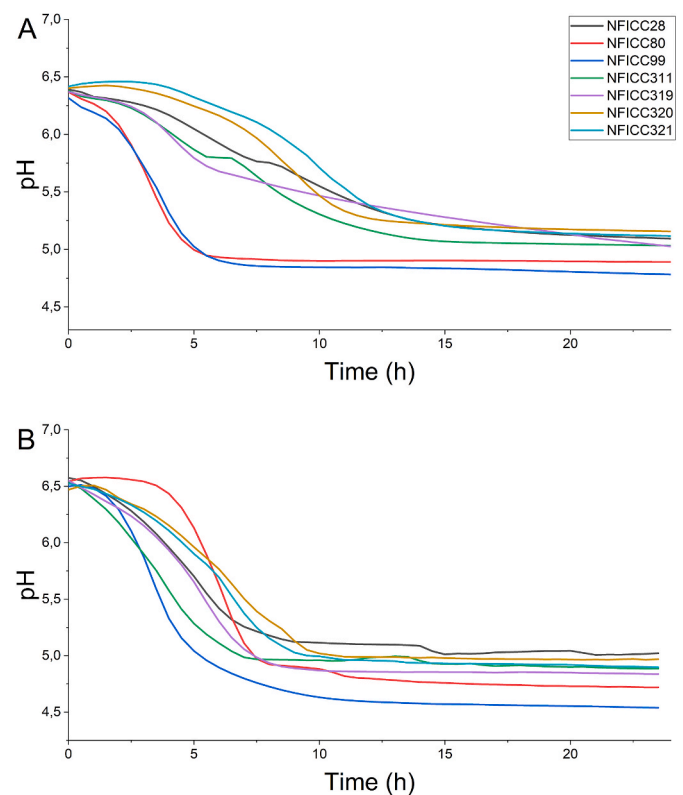

Fig. 3. Acidification of SFM. A) non-lyophilized strains, overnight culture in MRS. B) Lyophilized strains, using a soy-based lyoprotectant. $n = 3$.

activated in the process of lyophilization, which would in turn make for a faster turnover rate of carbohydrate to organic acids. The increased lag phase seen for NFICC80 after lyophilization could be linked to the low viability of long-term storage, indicating a generally lower tolerance for growth in SFM, compared to SM. On the other hand, it is worth noting that the acidification rate of NFICC80 is steeper than any of the other strains, acidifying SFM to a lower pH than all but NFICC99 after approximately 8 h.

3.3. Primary metabolism – HPLC

The primary metabolism of the *Leuconostoc* species is the consumption of simple sugars into lactate, acetate, and ethanol, and are important for their addition of various flavors and volatiles in both dairy and vegetable food fermentations (Frantzen et al., 2017; Jung et al., 2012, 2022; Yu et al., 2020). SFM were fermented using the seven candidate strains under aerobic conditions, to try and mimic the production settings of cheese during aging. HPLC and HS-SPME GC-MS were used to analyze both the primary metabolic products and the volatile compounds of their secondary metabolism, respectively. In this section we will describe and discuss the primary metabolites, and in the next section, the volatile secondary metabolites. For all strains, both NLC and LC were used, to see the effect of lyophilization on the fermented product. Samples were taken after 18 h and one week of fermentation.

Table 1 shows the initial concentration of fermentable sugars, as well as acetate, citrate, and ethanol present in SFM. As touched upon earlier, the presence of citrate is often linked to the production of the buttery flavor compounds acetoin and diacetyl in cheese production. In Fig. 4, the changes in concentrations (negative for consumption, positive for production) can be seen for all fermentations. All strains, both NLC and LC, were able to utilize glucose, fructose, sucrose, and citrate to varying degrees. None of the strains, in either condition, was able to remove all glucose from the medium. This is likely caused by a combination of acid inhibition from lactate production, but also partly by the breakdown of stachyose and raffinose, steadily supplying galactose, fructose, and glucose. This is especially apparent for NFICC311, which can partly convert the stachyose to raffinose, increasing the net amount of raffinose present, and increasing one of the breakdown products of stachyose.

For the NLC, only NFICC99 and NFICC311 metabolize any substantial amounts of stachyose, reducing the concentration by 3.29 g/L and 2.24 g/L respectively, after one week. For the LC fermentations, NFICC99 and NFICC311 showed increased efficiency, lowering the stachyose concentration by 6.26 g/L and 2.87 g/L respectively, but also NFICC28 and NFICC319 lowered concentrations of stachyose by 0.757 g/L, and 3.54 g/L respectively after one week. Citrate is being depleted for all fermentations already after 18 h, except for NFICC80, which only reduces the concentration by 1.68 g/L after a week in NLC fermentations but manages to deplete citrate within one week in LC fermentations.

In terms of primary metabolite production, lactate, and acetate were the two main products for all strains. NFICC99 had the highest final lactate concentration in NLC fermentations at 15.4 g/L, but interestingly slightly lower concentration for LC in favor of more acetate, ethanol, and mannitol. Furthermore, the high lactate concentration after 18 h for this strain, is in line with the fast acidification seen in Fig. 3. NFICC319 has the most noticeable change after lyophilization, reaching the highest lactate concentration among the LC fermentations at 13.1 g/L. This is in combination with the fact that it has a 27-fold increased stachyose consumption compared to the NLC fermentation. On the other hand, NFICC80 has the lowest production of both lactate and acetate in both

NLC and LC fermentations but instead produces the most ethanol. The low lactate production fits with a lower reduction in sugars, and the lower acetate production, combined with a higher ethanol production could be caused by the inability to fully metabolize citrate. This is because heterofermentatives, such as *Leuconostoc*, can utilize the citrate for lactate production to generate NAD⁺. This will in turn enable the cell to produce acetate, which yields ATP, instead of ethanol, which yields NAD⁺ (Koduru et al., 2017). NFICC80's lacking ability for citrate conversion will therefore cause a lower lactate and acetate production compared to the other strains while keeping ethanol production active.

Acetoin and diacetyl contribute with a buttery, creamy flavor, and they are often sought in certain amounts in dairy products. For the NLC fermentations, only NFICC99 was able to produce acetoin, which reached 0.487 g/L after one week, whereas diacetyl levels only reached trace amounts after 18 h but were gone after one week. Diacetyl is a highly volatile compound, and aerobic fermentation could cause a significant reduction in its concentration. During LC fermentations, NFICC80 and NFICC99 were able to reach acetoin concentrations of 0.274 g/L and 0.486 g/L after one week, and NFICC99 maintained trace amounts of diacetyl even after one week. While these acetoin concentrations are above the threshold values for human detection (800 ppb.) (Buttery et al., 1990), NFICC99 has previously been shown to produce much higher concentrations in other media under aerobic conditions (Øzmerih et al., 2023). Acetoin production in cheese is traditionally carried out by *Ln. mesenteroides*, but here the strains are added after acidification by *Lactococcus lactis*. In that case, the low pH and low lactose concentrations change the metabolic flux of citrate, which is then mainly turned into acetoin and diacetyl (Hemme and Foucaud-Scheunemann, 2004; Vedamuthu, 1994). This strategy of a two-step fermentation could potentially be employed in SFM as well, with a strain of *L. lactis* unable to metabolize citrate. This strategy could potentially redirect the flux of citrate towards acetoin and diacetyl production if increased levels of these flavors are desired.

The raffinose family oligosaccharides (RFO), together with sucrose, are the most common carbohydrates found in soybeans (Elango et al., 2022; Hagely et al., 2013; Karr-Lilienthal et al., 2005). At the same time, they are known to cause flatulence and discomfort in humans, increasing the importance of these carbohydrates to be fermented by our strains. With the *Ln. pseudomesenteroides* NFICC99 being the fastest acidifier, and the best performer in acetoin production and utilization of the present carbon sources, it would be an interesting strain to investigate as a production strain. Additionally, as the *Ln. mesenteroides* NFICC319 responded with increased efficiency to lyophilization, this strain would also be of increased interest.

3.4. Secondary metabolism – HS-SPME GC-MS

While NFICC99 was the most efficient candidate in terms of sugar consumption, and acid and acetoin production, there are more factors that play a role in the flavor profile of a cheese. To compare the fermented- and unfermented SFM with dairy cheese they were analyzed by HS-SPME GC-MS to measure the volatile flavors of the ferments. Furthermore, the detected volatiles were compared to that of five different dairy cheeses (Parmigiano Reggiano, Mascarpone, Cheddar, Danish “processed cheese” and Pecorino) which can be seen in Table 2. Only the volatiles which overlapped between fermented- or unfermented SFM and any of the cheeses were listed. In Supplementary Table S1, an overview of the flavor- and odor contribution of each volatile can be found.

Table 1

Composition of sugars, organic acids, dairy flavors, and ethanol in blank SFM medium.

Blank SFM (g/L)								
stachyose	raffinose	sucrose	galactose	glucose	fructose	citrate	acetate	EtOH
6,26	2,88	4,80	0,55	4,47	2,21	5,87	0,02	1,12

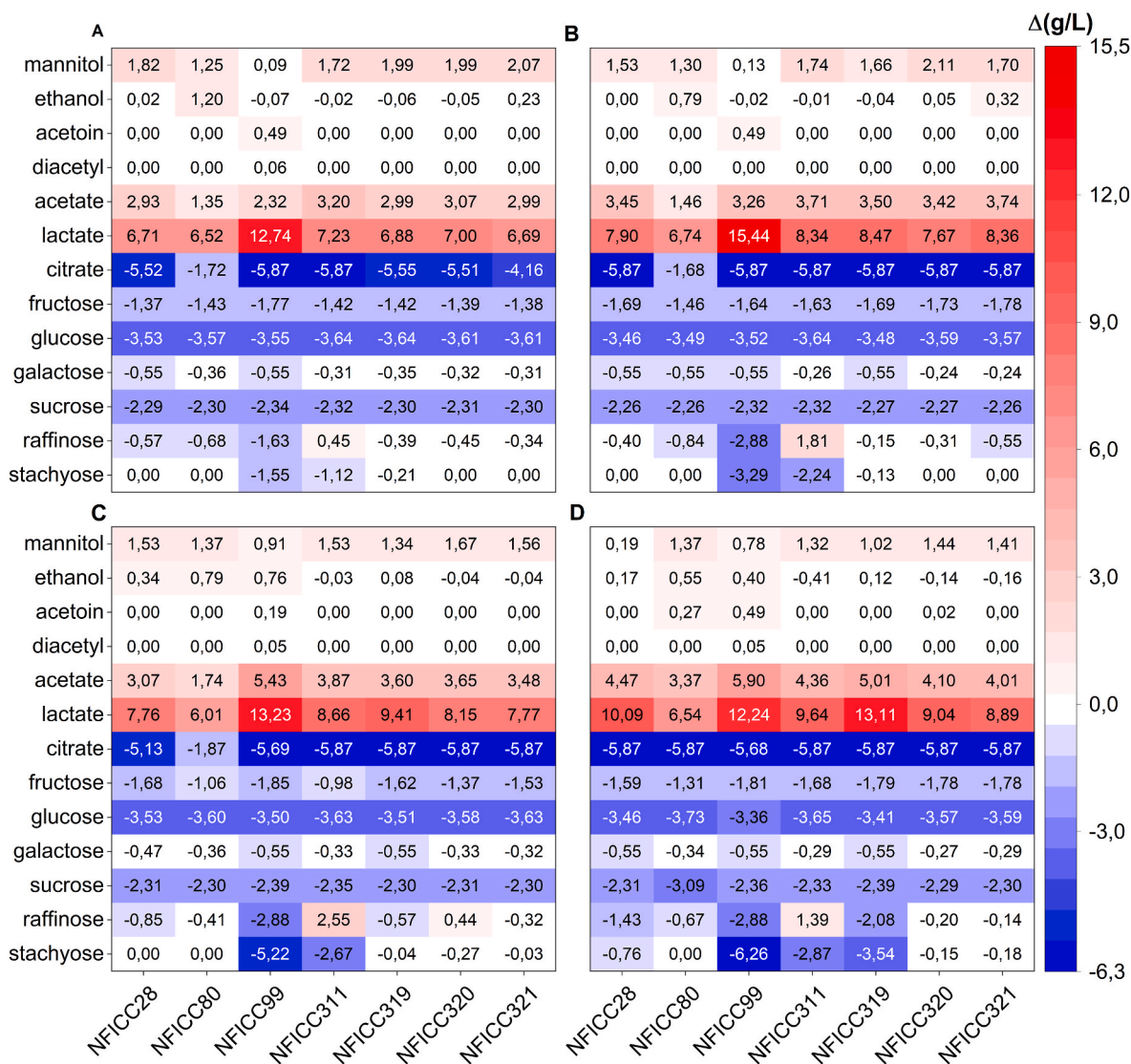

Fig. 4. Changes in concentrations (g/L) of sugars, organic acids, ethanol, acetoin, and diacetyl of fermented SFM, compared to unfermented SFM. A) non-lyophilized strains, 18h. B) non-lyophilized, 1 week. C) Lyophilized strains, 18h. D) Lyophilized strains, 1 week. Results obtained by HPLC. n = 3.

Interestingly, there was an overlap of 10 volatiles between the unfermented SFM and cheeses, two of them being hexanal and 2-pentylfuran usually regarded as off flavors with beany/grassy taste and odor (Hall and Anderson, 1985; Li and Wang, 2016). However, it seems that all of the investigated *Leuconostoc* strains, in both NLC and LC conditions were able to reduce these compounds below the detection limit after the first 18 h of fermentation. For NFICC80 (NLC) hexanal reappeared after one week of fermentation, as did it for NFICC311 and NFICC319 (LC). As hexanal is also found in cheddar and Danish “processed cheese”, it is not surprising that it might be a product of the strains late, secondary metabolism. Alternatively, it could be hypothesized that hexanal could be the result of the breakdown of aldehydes with a longer carbon backbone, such as decanal, nonanal, or octanal, which is also detected. Another shared capability is the production of pentan-1-ol in all strains. This volatile is only present in cheddar and is described as having a pungent, fermented, bready, yeasty, fusel, winy, and solvent-like flavor (Table S1), which should likely be kept at low levels to prevent a strong undesired flavor. By numbers of similar volatiles to the cheeses, NFICC99 had the highest count with 24 volatiles overlapping. Next came NFICC319 with 23 volatiles, then NFICC80 and NFICC320 with both 17 volatiles. NFICC28 and NFICC311 both had 16 overlapping volatiles, and NFICC321 had the lowest amount of 14. NFICC99 generally

produced more of the nutty, buttery, and cheese-like flavors such as benzaldehyde, 3-methylbutanoic acid, butane-2,3-diol, acetoin, 2-phenylacetaldehyde, and 2-phenylethanol, which was not present consistently in most of the other strains. On the other hand, NFICC80 and NFICC321, which were two of the underperformers in terms of sugar metabolism, produced octan-2-one in the later stages of fermentation, which is described as a bleu and parmesan cheese-like with earthy and dairy nuances odor. Other noteworthy volatiles like heptan-2-one (banana, fruity), and nonan-2-one (fruity, cheese, coconut-like), were produced in some, but not all the strains, in no apparent pattern. In general, it was difficult to assess any patterns in the volatilome of the fermentations, as some volatiles appeared after 18 h but disappeared again at a later time point while other volatiles only appeared in the late stage of fermentation. The lyophilization process also did not show any clear changes in behavior with the current data available. This is a positive indication, as strains may then be screened directly for VOC production, instead of having to go through the laborious process of lyophilizing them first. These results illustrate the intricate and complicated area which is food fermentation, and a stronger dataset should be generated to better clarify if the lyophilization process could affect the VOCs produced by the strains. To fully mimic a dairy cheese there is a long way to go, but the results shown in this study reveal that

at least parts of the right flavor combination can be achieved by implementing lactic acid fermentation in the process of making plant-based cheese alternatives.

3.5. Genomic profile

To uncover the mechanisms behind the phenotypical traits seen for the primary metabolites, we investigated the genomic profile of the strains. Specifically, we searched for genes related to RFO and sucrose metabolism, as these traits are some of the fundamental machineries for fermentation in SFM and flavor production.

Fig. 5 shows the presence of an α -galactosidase gene cluster, harboring a raffinose permease (*lacS*), transcriptional regulator (*lacI*), an α -galactosidase (*galA*), a galactokinase (*galK*), and a galactose-1-phosphate uridylyltransferase (*galT*) (Gänzle and Follador, 2012; Harlé et al., 2020; Yu et al., 2021). All strains, except NFICC28 harbored the necessary genes for successful RFO internalization and hydrolyzation. Interestingly, the genome of *Ln. citreum* strain NFICC28 did not contain any of the genes involved in RFO metabolism, though there is some activity seen for raffinose conversion for the strain (Fig. 4). This cannot be explained by the knowledge we currently have available. Additionally for NFICC28, it has been previously shown to have some inhibitory effect on food spoilage *Bacillus* species (Iosca et al., 2023). *Ln. lactis* NFICC80 had two additional genes connected to the gene cluster, an aldose 1-epimerase (*galM*) and a β -galactosidase (*lacZ*). These two genes are involved in the conversion of lactose, and they are therefore not directly associated with the aim of this study. But it does show the diversity within the investigated strains. As this strain did not perform considerably well in either survival rate in soyMRS:SFM, or in utilizing the RFOs, it might have better capabilities in substrates supplied with lactose. This could also partly explain why it had a higher survival rate in the lyoprotectant supplied with skim milk. The large difference in stachyose- and raffinose consumption for the four *Ln. mesenteroides* strains NFICC311, NFICC319, NFICC320, and NFICC321 is interesting, as they all contained the same cluster for RFO utilization. Others, who have investigated the utilization of soybean carbohydrates (Yu et al., 2021), found that strains of *Ln. mesenteroides* with interpositioned *lacI* between *lacS* and *galA* had a much lower α -galactosidase activity compared to strains lacking the *lacI* gene. They hypothesize that LacI might act as a repressor of *galA*, lowering the activity of the α -galactosidase enzyme. If this is the case, the four strains of *Ln. mesenteroides* here might have slightly different expression patterns of *lacI*, resulting in a varying degree of RFO consumption. Interestingly, it does not seem that *Ln. pseudomesenteroides* NFICC99 was equally halted by the presence

of *lacI*, as it converted almost 2-fold the amount of stachyose as NFICC319, which was the second most efficient strain.

Sucrose is another major carbohydrate present in SFM, but also the breakdown product of RFOs. It is also generally abundant in all plant-based foods, making the utilization of sucrose a very important feature for strains used in plant-based fermentations (Huang et al., 2023). In Fig. 6, the presence of a sucrose utilization gene cluster in each strain can be seen. Overall, all strains had the necessary machinery for sucrose transport and hydrolysis into glucose and fructose. The core of the cluster are genes encoding a PTS system sucrose-specific EIIBC component (*scrA*), an invertase (*sacA*) and a sucrose operon repressor (*scrR*), which was present in all strains. Additionally, the *Ln. lactis* and *Ln. mesenteroides* strains harbored a gene encoding a fructokinase (*scrK*), which is responsible for the phosphorylation of fructose when channeling it into the glycolysis pathway. The lack of this gene in the cluster for NFICC28 and NFICC99 could indicate a lack of function for sucrose utilization. Interestingly this does not seem apparent in the results in Fig. 4, highlighting the importance of combining modern WGS approaches with phenotypical investigations. *Leuconostoc* is widely known for converting fructose into mannitol, to generate NAD⁺ (Dols et al., 1997; Martínez-Miranda et al., 2022). The responsible enzyme, a mannitol dehydrogenase, was also found in all strains. For NFICC28 and

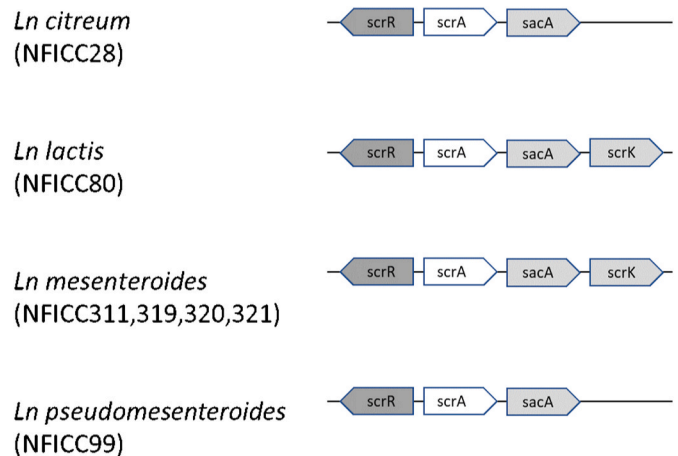

Fig. 6. Genetic presence of sucrose utilization-related gene clusters, grouped by species. The presented size of the gene is not representative of the gene's actual length. *scrR*: sucrose operon suppressor, *scrA*: PTS system sucrose-specific EIIBC component, *sacA*: invertase, *scrK*: fructokinase.

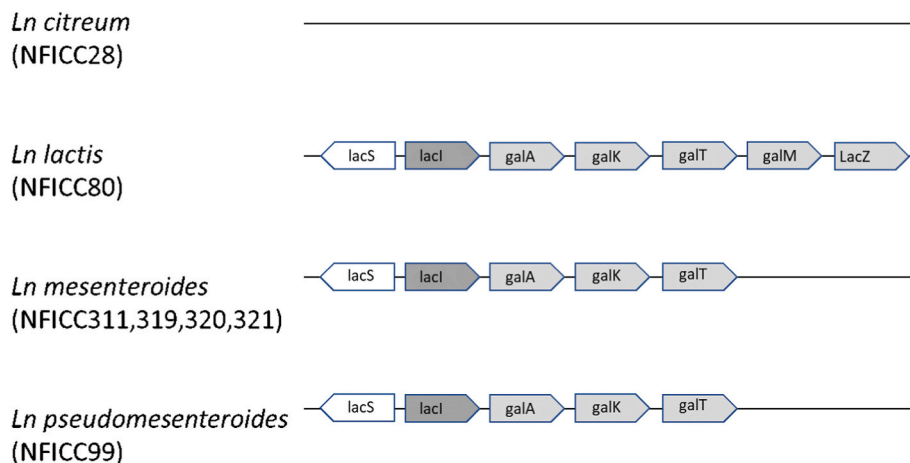

Fig. 5. Genetic presence of α -galactosidase-related gene clusters, grouped by species. The presented size of the gene is not representative of the gene's actual length. *lacS*: raffinose permease, *lacI*: transcriptional regulator, *galA*: α -galactosidase, *galK*: galactokinase, *galT*: galactose-1-phosphate uridylyltransferase, *galM*: aldose 1-epimerase, *lacZ*: β -galactosidase.

NFICC99 a gene encoding a fructokinase was found in proximity to a mannitol dehydrogenase gene (data not shown), which might indicate that the control of these functions is more co-regulated for these strains. The presence of the sucrose cluster, as well as the composition of genes, is in accordance with other studies (Yu et al., 2021) and with the observed phenotypes.

4. Conclusion

In this study, we aimed to investigate soybean flour as a lyoprotectant for selected *Leuconostoc* strains, as well as the ability of the strains to produce cheese-related flavors in SFM. To our knowledge, this is the first study that investigates the use of this lyoprotectant for *Leuconostoc*. Furthermore, it is the first study to investigate the impact of this specific process on the metabolic profile of the *Leuconostoc* genus. Strains that were lyophilized in soyMRS:SFM were able to maintain high viability during the lyophilization process, comparable to that of MRS:SM. On the other hand, SFM did not perform as well in terms of long-term storage, where viability for especially NFICC80 decreased substantially. More research could be done in trying to supplement with lipids, additional carbon sources, or other stabilizing agents known to work in other cases. We also saw that most of the strains had an increased efficiency in terms of acidification rate and, sugar consumption and in some cases an altered volatilome. All the strains were able to metabolize and remove certain volatiles found in SFM, such as hexanal. This is an important feature, in terms of reduction of off-flavors for plant-based dairy alternatives in the future. Still, the flavor profile of cheese is complex to mimic, and the results here highlights the intricacy involved in creating convincing alternatives. Among all the strains, NFICC99 was the most efficient strain in terms of reducing the amounts of stachyose, as well as producing the dairy-related flavors acetoin, diacetyl, and butane-2,3-diol, as well as several other cheese-related VOCs. At the same time, it is the only *Ln. pseudomesenteroides*, which is interesting, as it is normally *Ln. mesenteroides* strains which are known as the flavor-producing lactic acid bacteria in dairy cheeses. It would be of interest to further investigate the volatilome of NFICC99 under various conditions, such as in a co-culture with other lactic acid bacteria, to see if there can be synergistic effects in the production of valuable flavor compounds. Much research needs to be done in this area before we can reach alternatives effectively mimicking dairy cheese. But here we show some of the potential of plant-derived *Leuconostoc* for creating new fermented plant-based alternatives.

Declaration of competing interest

The authors declare that they have no known competing financial interests or personal relationships that could have appeared to influence the work reported in this paper.

5 Acknowledgements

Anders Peter Wätjen and Wenkang Huang acknowledge the award of a scholarship from a joint Strategic alliance PhD initiative between the University of Queensland and Technical University of Denmark. We thank Preben Nielsen and Mads Bjørnqvad at Novozymes A/S for DNA extraction and sequencing results, and the research infrastructure Open Innovation FOOD & Health Laboratory (FOODHAY) for contributing the equipment needed for MALDI-TOF Biotyping. Finally, a big thank you to professors Maria Gullo and Andrea Pulvirenti of University of Modena and Reggio Emilia for laboratory accommodations and good collaborations.

Appendix A. Supplementary data

Supplementary data to this article can be found online at <https://doi.org/10.1016/j.fm.2023.104337>.

References

- Arora, G., Cormier, F., Lee, B., 1995. Analysis of odor-active volatiles in cheddar cheese headspace by multidimensional GC/MS/sniffing. *J. Agric. Food Chem.* 43, 748–752. <https://doi.org/10.1021/jf00051a035>.
- Barraquio, V.L., van de Voort, F.R., 1988. Milk and soy proteins: their status in review. *Can. Inst. Food Sci. Technol. J.* 21, 477–493. [https://doi.org/10.1016/s0315-5463\(88\)71028-7](https://doi.org/10.1016/s0315-5463(88)71028-7).
- Bodzen, A., Jossier, A., Dupont, S., Mousset, P.Y., Beney, L., Lafay, S., Gervais, P., 2021. Design of a new lyoprotectant increasing freeze-dried *Lactobacillus* strain survival to long-term storage. *BMC Biotechnol.* 21, 1–10. <https://doi.org/10.1186/s12896-021-00726-2>.
- Buttery, R.G., Teranishi, R., Ling, L.C., Turnbaugh, J.G., 1990. Quantitative and sensory studies on tomato paste volatiles. *J. Agric. Food Chem.* 38, 336–340. <https://doi.org/10.1021/jf00091a074>.
- Capozzi, V., Lonzarich, V., Khomenko, I., Cappellin, L., Navarini, L., Biasioli, F., 2020. Unveiling the molecular basis of Mascarpone cheese aroma: VOCs analysis by SPME-GC/MS and PTR-ToF-MS. *Molecules* 25. <https://doi.org/10.3390/molecules25051242>.
- Cheng, Z., Yan, X., Wu, J., Weng, P., Wu, Z., 2022. Effects of freeze drying in complex lyoprotectants on the survival, and membrane fatty acid composition of *Lactobacillus plantarum* L1 and *Lactobacillus fermentum* L2. *Cryobiology* 105, 1–9. <https://doi.org/10.1016/j.cryobiol.2022.01.003>.
- Choi, I.S., Ko, S.H., Kim, H.M., Yang, J.E., Jeong, S.G., Chang, J.Y., Lee, K.H., Qi, S.B., Xin, Q., Cui, C.B., Moon, J.H., Park, H.W., 2020. Coffee residue as a valorization bio-agent for shelf-life extension of lactic acid bacteria under cryopreservation. *Waste Manag.* 118, 585–590. <https://doi.org/10.1016/j.wasman.2020.09.025>.
- Day, J.G., Stacey, G.N., 2007. Cryopreservation and Freeze-Drying Protocols. *Methods Mol. Biol.* Volume, 368.
- Di Donato, F., Biancolillo, A., Mazzulli, D., Rossi, L., D'Archivio, A.A., 2021. HS-SPME/GC-MS volatile fraction determination and chemometrics for the discrimination of typical Italian Pecorino cheeses. *Microchem. J.* 165, 106133. <https://doi.org/10.1016/j.microm.2021.106133>.
- Dols, M., Chraïbi, W., Rемаud-Simeon, M., Lindley, N.D., Monsan, P.F., 1997. Growth and energetics of *Leuconostoc mesenteroides* NRRL B-1299 during metabolism of various sugars and their consequences for dextranase production. *Appl. Environ. Microbiol.* 6, 2159–2165. <https://doi.org/10.1128/aem.63.6.2159-2165.1997>.
- Durica-Mitic, S., Göpel, Y., Görke, B., 2018. Carbohydrate utilization in bacteria: making the most out of sugars with the help of small regulatory RNAs. *Microbiol. Spectr.* 6. <https://doi.org/10.1128/microbiolspec.rwr-0013-2017>.
- Elango, D., Rajendran, K., Van der Laan, L., Sebastiar, S., Raigne, J., Thaiparambil, N.A., El Haddad, N., Raja, B., Wang, W., Ferella, A., Chiteri, K.O., Thudi, M., Varshney, R. K., Chopra, S., Singh, A., Singh, A.K., 2022. Raffinose family oligosaccharides: friend or foe for human and plant health? *Front. Plant Sci.* 13, 1–16. <https://doi.org/10.3389/fpls.2022.829118>.
- Frantzen, C.A., Kot, W., Pedersen, T.B., Ardö, Y.M., Broadbent, J.R., Neve, H., Hansen, L. H., Bello, F.D., Østlie, H.M., Kleppen, H.P., Vogensen, F.K., Holo, H., 2017. Genomic characterization of dairy associated *Leuconostoc* species and diversity of *leuconostocs* in undefined mixed mesophilic starter cultures. *Front. Microbiol.* 8. <https://doi.org/10.3389/fmicb.2017.00132>.
- Gänzle, M.G., Follador, R., 2012. Metabolism of oligosaccharides and starch in *lactobacilli*: a review. *Front. Microbiol.* 3, 1–15. <https://doi.org/10.3389/fmicb.2012.00340>.
- Gurevich, A., Saveliev, V., Vyahhi, N., Tesler, G., 2013. QUASt: quality assessment tool for genome assemblies. *Bioinformatics* 29, 1072–1075. <https://doi.org/10.1093/bioinformatics/btt086>.
- Gwak, H.J., Lee, J.H., Kim, T.W., Choi, H.J., Jang, J.Y., Lee, S. Il, Park, H.W., 2015. Protective effect of soy powder and microencapsulation on freeze-dried *Lactobacillus brevis* WK12 and *Lactococcus lactis* WK11 during storage. *Food Sci. Biotechnol.* 24, 2155–2160. <https://doi.org/10.1007/s10068-015-0287-5>.
- Hagely, K.B., Palmquist, D., Bilyeu, K.D., 2013. Classification of distinct seed carbohydrate profiles in soybean. *Journal* 61, 1105–1111.
- Hall, G., Anderson, J., 1985. Flavor changes in whole milk powder during storage: relationships between flavor properties and volatile compounds. *J. Food Qual.* 7, 237–253. <https://doi.org/10.1111/j.1745-4557.1985.tb01056.x>.
- Harlé, O., Falentin, H., Niay, J., Valence, F., Courselaud, C., Chuat, V., Maillard, M.B., Guédon, É., Deutsch, S.M., Thierry, A., 2020. Diversity of the metabolic profiles of a broad range of lactic acid bacteria in soy juice fermentation. *Food Microbiol.* 89, 103410. <https://doi.org/10.1016/j.fm.2019.103410>.
- Hemme, D., Foucaud-Scheunemann, C., 2004. *Leuconostoc*, characteristics, use in dairy technology and prospects in functional foods. *Int. Dairy J.* 14, 467–494. <https://doi.org/10.1016/j.idairy.2003.10.005>.
- Huang, W., Dong, A., Pham, H.T., Zhou, C., Huo, Z., Wätjen, A.P., Prakash, S., Bang-Berthelsen, C.H., Turner, M.S., 2023. Evaluation of the fermentation potential of lactic acid bacteria isolated from herbs, fruits and vegetables as starter cultures in nut-based milk alternatives. *Food Microbiol.* 112, 104243. <https://doi.org/10.1016/j.fm.2023.104243>.
- Huang, W., Wätjen, A.P., Prakash, S., Bang-Berthelsen, C.H., Turner, M.S., 2022. Exploring lactic acid bacteria diversity for better fermentation of plant-based dairy alternatives. *Microbiol. Australia* 43, 79–82. <https://doi.org/10.1071/MA22026>.
- Iosca, G., Fugaban, J.L.L., Özmerih, S., Wätjen, A.P., Kaas, R.S., Hä, Q., Shetty, R., Pulvirenti, A., De Vero, L., Bang-Berthelsen, C.H., 2023. Exploring the inhibitory activity of selected lactic acid bacteria against bread rope spoilage agents. *Fermentation* 9 (3), 290. <https://doi.org/10.3390/fermentation9030290>.
- Jawan, R., Abbasiliasi, S., Tan, J.S., Kapri, M.R., Mustafa, S., Halim, M., Ariff, A.B., 2022. Influence of type and concentration of lyoprotectants, storage temperature and

- storage duration on cell viability and antibacterial activity of freeze-dried lactic acid bacterium, *Lactococcus lactis* Gh1. *Drying Technol.* 40, 1774–1790. <https://doi.org/10.1080/07373937.2021.1874968>.
- Jung, J.Y., Lee, S.H., Lee, H.J., Seo, H.Y., Park, W.S., Jeon, C.O., 2012. Effects of *Leuconostoc mesenteroides* starter cultures on microbial communities and metabolites during kimchi fermentation. *Int. J. Food Microbiol.* 153, 378–387. <https://doi.org/10.1016/j.ijfoodmicro.2011.11.030>.
- Jung, M.J., Kim, J., Lee, S.H., Whon, T.W., Sung, H., Bae, J.W., Choi, Y.E., Roh, S.W., 2022. Role of combined lactic acid bacteria in bacterial, viral, and metabolite dynamics during fermentation of vegetable food, kimchi. *Food Res. Int.* 157, 111261. <https://doi.org/10.1016/j.foodres.2022.111261>.
- Karr-Lilienthal, L.K., Kadzere, C.T., Grieshop, C.M., Fahey, G.C., 2005. Chemical and nutritional properties of soybean carbohydrates as related to nonruminants: a review. *Livest. Prod. Sci.* 97, 1–12. <https://doi.org/10.1016/j.livprodsci.2005.01.015>.
- Kihal, M., Prévost, H., Lhotte, M.E., Huang, D.Q., Diviès, C., 1996. Instability of plasmid-encoded citrate permease in *Leuconostoc*. *Lett. Appl. Microbiol.* 22, 219–223. <https://doi.org/10.1111/j.1472-765X.1996.tb01147.x>.
- Koduru, L., Kim, Y., Bang, J., Lakshmanan, M., Han, N.S., Lee, D.Y., 2017. Genome-scale modeling and transcriptome analysis of *Leuconostoc mesenteroides* unravel the redox governed metabolic states in obligate heterofermentative lactic acid bacteria. *Sci. Rep.* 7, 1–15. <https://doi.org/10.1038/s41598-017-16026-9>.
- Li, Y.H., Wang, W.J., 2016. Short communication: formation of oxidized flavor compounds in concentrated milk and distillate during milk concentration. *J. Dairy Sci.* 99, 9647–9651. <https://doi.org/10.3168/jds.2016-11619>.
- Lin, J., Schmitt, P., Diviès, C., 1991. Characterization of a citrate-negative mutant of *Leuconostoc mesenteroides* subsp. *mesenteroides*: metabolic and plasmidic properties. *Appl. Microbiol. Biotechnol.* 34, 628–631. <https://doi.org/10.1007/BF00167912>.
- Mahidsanan, T., Gasaluck, P., Eumkeb, G., 2017. A novel soybean flour as a cryoprotectant in freeze-dried *Bacillus subtilis* SB-MYP-1. *Lwt* 77, 152–159. <https://doi.org/10.1016/j.lwt.2016.11.015>.
- Martínez-Miranda, J.G., Chairez, I., Durán-Páramo, E., 2022. Mannitol production by heterofermentative lactic acid bacteria: a review. *Appl. Biochem. Biotechnol.* 194 (6), 2762–2795. <https://doi.org/10.1007/s12010-022-03836-5>.
- Núñez-Carmona, Estefanía, Abbatangelo, Marco, Zottele, Ivano, Piccoli, Pierpaolo, Tamanini, Armando, Comini, Elisabetta, Giorgio Sberveglieri, Sberveglieri, Veronica, 2019a. Nanomaterial gas sensors for online monitoring system of fruit jams. *Foods* 8 (12), 632. <https://doi.org/10.3390/foods8120632>.
- Núñez-Carmona, Estefanía, Abbatangelo, Marco, Sberveglieri, Veronica, 2019b. Innovative sensor approach to follow *Campylobacter jejuni* development. *Biosensors* 9 (1), 8. <https://doi.org/10.3390/bios9010008>.
- Özcan, E., Selvi, S.S., Nikerel, E., Teusink, B., Toksoy Öner, E., Çakır, T., 2019. A genome-scale metabolic network of the aroma bacterium *Leuconostoc mesenteroides* subsp. *cremoris*. *Appl. Microbiol. Biotechnol.* 103, 3153–3165. <https://doi.org/10.1007/s00253-019-09630-4>.
- Øzmerih, S., Wätjen, A.P., Shetty, R., Madsen, S.K., 2023. Utilization of plant isolated lactic acid bacteria for efficient bioconversion of brewers' spent grain into acetoin. *Int. J. Food Microbiol.* In review.
- Pedersen, T.B., Ristagno, D., McSweeney, P.L.H., Vogensen, F.K., Ardö, Y., 2013. Potential impact on cheese flavour of heterofermentative bacteria from starter cultures. *Int. Dairy J.* 33, 112–119. <https://doi.org/10.1016/j.idairyj.2013.03.003>.
- Peiren, J., Hellemans, A., De Vos, P., 2016. Impact of the freeze-drying process on product appearance, residual moisture content, viability, and batch uniformity of freeze-dried bacterial cultures safeguarded at culture collections. *Appl. Microbiol. Biotechnol.* 100, 6239–6249. <https://doi.org/10.1007/s00253-016-7359-1>.
- Quintana, G., Gerbino, E., Gómez-Zavaglia, A., 2017. Okara: a nutritionally valuable by-product able to stabilize *Lactobacillus plantarum* during freeze-drying, spray-drying, and storage. *Front. Microbiol.* 8, 1–9. <https://doi.org/10.3389/fmicb.2017.00641>.
- Sberveglieri, V., Bhandari, M.P., Carmona, E.N., Betto, G., Sberveglieri, G., 2016. A novel MOS nanowire gas sensor device (S3) and GC-MS-based approach for the characterization of grated parmigiano reggiano cheese. *Biosensors* 6. <https://doi.org/10.3390/bios6040060>.
- Shin, S.Y., Han, N.S., 2015. *Leuconostoc* spp. as starters and their beneficial roles in fermented foods. In: Liang, M.T. (Ed.), *Beneficial Microorganisms in Food and Nutraceuticals*. Microbiology Monographs, vol. 27. Springer, Cham. https://doi.org/10.1007/978-3-319-23177-8_5.
- Steensels, J., Gallone, B., Voordeckers, K., Verstrepen, K.J., 2019. Domestication of industrial microbes. *Curr. Biol.* 29, 381–393. <https://doi.org/10.1016/j.cub.2019.04.025>.
- Sunesen, L.O., Lund, P., Sørensen, J., Hølmer, G., 2002. Development of volatile compounds in processed cheese during storage. *LWT - Food Sci. Technol. (Lebensmittel-Wissenschaft -Technol.)* 35, 128–134. <https://doi.org/10.1006/food.2001.0815>.
- Takeshi, S., Kuroshima, K., 1997. Viabilities of dried cultures of various bacteria after preservation for over 20 years and their prediction by the accelerated storage test. *Microbiology and Culture Collections* 13 (1), 1–7.
- Vaughan, E.E., David, S., Harrington, A., Daly, C., Fitzgerald, G.F., De Vos, W.M., 1995. Characterization of plasmid-encoded citrate permease (citP) genes from *Leuconostoc* species reveals high sequence conservation with the *Lactococcus lactis* citP gene. *Appl. Environ. Microbiol.* 61, 3172–3176. <https://doi.org/10.1128/aem.61.8.3172-3176.1995>.
- Vedamuthu, E.R., 1994. The dairy *Leuconostoc*: use in dairy products. *J. Dairy Sci.* 77, 2725–2737. [https://doi.org/10.3168/jds.S0022-0302\(94\)77215-5](https://doi.org/10.3168/jds.S0022-0302(94)77215-5).
- Walther, B., Guggisberg, D., Badertscher, R., Egger, L., Portmann, R., Dubois, S., Haldimann, M., Kopf-Bolan, K., Rhyn, P., Zoller, O., Veraguth, R., Rezzi, S., 2022. Comparison of nutritional composition between plant-based drinks and cow's milk. *Front. Nutr.* 9. <https://doi.org/10.3389/fnut.2022.988707>.
- Wang, Y.C., Yu, R.C., Chou, C.C., 2004. Viability of lactic acid bacteria and *bifidobacteria* in fermented soymilk after drying, subsequent rehydration and storage. *Int. J. Food Microbiol.* 93, 209–217. <https://doi.org/10.1016/j.ijfoodmicro.2003.12.001>.
- Yu, A.O., Leveau, J.H.J., Marco, M.L., 2020. Abundance, diversity and plant-specific adaptations of plant-associated lactic acid bacteria. *Environ. Microbiol. Rep.* 12, 16–29. <https://doi.org/10.1111/1758-2229.12794>.
- Yu, P., Zhao, Y., Jiang, Y., Yang, Y., Liu, X., Zhang, Heping, Zhao, J., Lee, Y. kun, Zhang, Hao, Chen, W., 2021. Capacity of soybean carbohydrate metabolism in *Leuconostoc mesenteroides*, *Lactococcus lactis* and *Streptococcus thermophilus*. *Food Biosci.* 44, 101381. <https://doi.org/10.1016/j.fbio.2021.101381>.
- Zioga, E., Tøstesen, M., Kjærulff Madsen, S., Shetty, R., Bang-Berthelsen, C.H., 2022. Bringing plant-based Cli-meat closer to original meat experience: insights in flavor. *Future Foods* 5, 100138. <https://doi.org/10.1016/j.fufo.2022.100138>.

Update

Food Microbiology

Volume 117, Issue , February 2024, Page

DOI: <https://doi.org/10.1016/j.fm.2023.104371>

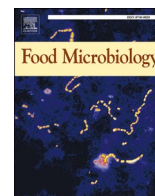

Corrigendum

Corrigendum to: *Leuconostoc* performance in soy-based fermentations – Survival, acidification, sugar metabolism, and flavor comparisons [Food Microbiol. 115 (2023) 104337]

Anders Peter Wätjen^a, Luciana De Vero^b, Estefania Núñez Carmona^c, Veronica Sberveglieri^{c,d}, Wenkang Huang^e, Mark S. Turner^e, Claus Heiner Bang-Berthelsen^{a,*}

^a National Food Institute, Technical University of Denmark, 2800, Kgs. Lyngby, Denmark

^b Department of Life Sciences, University of Modena and Reggio Emilia, 42122, Reggio Emilia, Italy

^c National Research Council, Institute of Bioscience and Bioresources (CNR-IBBR), Via J.F. Kennedy, 17/i, 42124, Reggio Emilia, Italy

^d Nano Sensor Systems, NASYS Spin-Off University of Brescia, 25125, Brescia, Italy

^e School of Agriculture and Food Sciences, University of Queensland, Brisbane, Queensland, Australia



The authors regret Figure 2 of the paper in question had missing graphics, specifically the asterisks indicating significantly lower survival rate in soy-flour based media compared to skimmed milk media. The media file sent with the final manuscript was a wrong version, in which it was not included. We would like correct this, by providing the updated version of the figure. It can be found below, as well as attached to the email together with this document.

Table 2, which was originally spread over two pages in the manuscript, is fitted into one page in the published paper. That in itself is no

issue, but the formatting still includes two headers, as well as two different margins for the columns in the table. While we have tried to reformat the table, to fit one A4 page, we were unable to do so without compromising the readability. If the editorial staff at Elsevier/Food Microbiology finds it necessary to correct this, and have the capability to do so, the authors would be grateful. However, this alteration might be skipped, as the authors finds that readability is of high priority.

The authors would like to apologise for any inconvenience caused.

DOI of original article: <https://doi.org/10.1016/j.fm.2023.104337>.

* Corresponding author.

E-mail address: claban@food.dtu.dk (C.H. Bang-Berthelsen).

<https://doi.org/10.1016/j.fm.2023.104371>

Available online 14 September 2023

0740-0020/© 2023 The Author(s). Published by Elsevier Ltd. All rights reserved.

