



US009728411B2

(12) **United States Patent**
Alberti et al.

(10) **Patent No.:** **US 9,728,411 B2**
(45) **Date of Patent:** **Aug. 8, 2017**

(54) **INTEGRATED CIRCUITS WITH BACKSIDE METALIZATION AND PRODUCTION METHOD THEREOF**

(75) Inventors: **Alessandra Alberti**, Catania (IT); **Paolo Badala'**, Catania (IT); **Antonello Santangelo**, Belpasso (IT)

(73) Assignee: **STMICROELECTRONICS S.R.L.**, Agrate, Brianza (IT)

(*) Notice: Subject to any disclaimer, the term of this patent is extended or adjusted under 35 U.S.C. 154(b) by 85 days.

(21) Appl. No.: **13/281,370**

(22) Filed: **Oct. 25, 2011**

(65) **Prior Publication Data**
US 2012/0098135 A1 Apr. 26, 2012

(30) **Foreign Application Priority Data**
Oct. 25, 2010 (IT) MI2010A1963

(51) **Int. Cl.**
H01L 23/498 (2006.01)
H01L 23/495 (2006.01)
(Continued)

(52) **U.S. Cl.**
CPC .. **H01L 21/28518** (2013.01); **H01L 21/28568** (2013.01); **H01L 23/4827** (2013.01); **H01L 24/03** (2013.01); **H01L 24/05** (2013.01); **H01L 24/06** (2013.01); **H01L 24/94** (2013.01); **H01L 2224/0345** (2013.01); **H01L 2224/0401** (2013.01); **H01L 2224/04026** (2013.01); **H01L 2224/04042** (2013.01); **H01L 2224/05155** (2013.01); **H01L 2224/05639** (2013.01); **H01L 2224/05644** (2013.01); **H01L 2224/05655** (2013.01); **H01L 2224/06181** (2013.01); **H01L 2224/94** (2013.01); **H01L 2924/0132** (2013.01);
(Continued)

(58) **Field of Classification Search**
CPC H01L 2924/01028; H01L 2224/13155
USPC 257/754, 737, 666, E23.01, E23.072
See application file for complete search history.

(56) **References Cited**
U.S. PATENT DOCUMENTS
3,985,515 A 10/1976 Greeson et al.
4,042,951 A 8/1977 Robinson et al.
(Continued)

FOREIGN PATENT DOCUMENTS
WO 2008050251 5/2008

OTHER PUBLICATIONS
Search report based on Italian application MI20101963, Ministero dello Sviluppo Economico, Munich, May 25, 2011, 3 pages.

Primary Examiner — Bradley K Smith
Assistant Examiner — David Goodwin
(74) *Attorney, Agent, or Firm* — Seed IP Law Group LLP

(57) **ABSTRACT**
An embodiment of an integrated device, including a chip of semiconductor material wherein an integrated circuit is integrated, is proposed; the integrated device includes a set of contact terminals for contacting the integrated circuit. At least one contact terminal of said set of contact terminals includes a contact layer of metal material being suitable to be directly coupled mechanically to an element external to the chip, and a coupling element for improving an electrical and/or mechanical coupling between the contact layer and the chip. The coupling element includes a coupling layer being formed by a combination between the metal material of the contact layer and the semiconductor material of the chip, with the coupling layer that is directly coupled to the chip and to the contact layer.

15 Claims, 7 Drawing Sheets

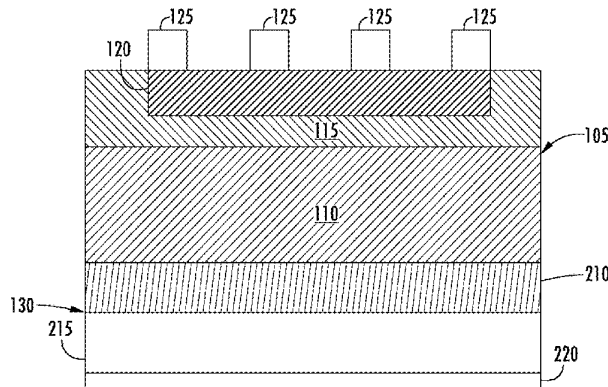

US 9,728,411 B2

Page 2

| | | |
|------|---|--|
| (51) | Int. Cl. H01L 21/285 (2006.01) H01L 23/482 (2006.01) H01L 23/00 (2006.01) | 6,426,248 B2* 7/2002 Francis et al. 438/197 2001/0006409 A1 7/2001 Lee 2002/0019084 A1* 2/2002 Francis H01L 29/7802 438/197 2003/0029705 A1 2/2003 Qiu et al. 2005/0253205 A1* 11/2005 Kawamura H01L 21/28518 257/412 2006/0114948 A1 6/2006 Lo et al. 2008/0185618 A1* 8/2008 Chu et al. 257/292 2008/0230911 A1 9/2008 Li 2009/0297774 A1* 12/2009 Chaudhari C03C 17/3618 428/149 2010/0087061 A1* 4/2010 Mai et al. 438/664 2011/0006409 A1* 1/2011 Gruenhagen H01L 24/05 257/666 2011/0124146 A1* 5/2011 Pitera et al. 438/64 2011/0143495 A1* 6/2011 Pitera et al. 438/94 2012/0080686 A1* 4/2012 Mauder et al. 257/76 |
| (52) | U.S. Cl. CPC <i>H01L 2924/01322</i> (2013.01); <i>H01L 2924/10253</i> (2013.01); <i>H01L 2924/12032</i> (2013.01); <i>H01L 2924/14</i> (2013.01) | |
| (56) | References Cited U.S. PATENT DOCUMENTS 4,554,045 A 11/1985 Bean et al. 4,597,029 A * 6/1986 Kucharek H05K 7/1053 257/691 5,217,922 A * 6/1993 Akasaki et al. 438/125 5,360,765 A * 11/1994 Kondo et al. 438/656 6,413,851 B1* 7/2002 Chow et al. 438/613 | * cited by examiner |

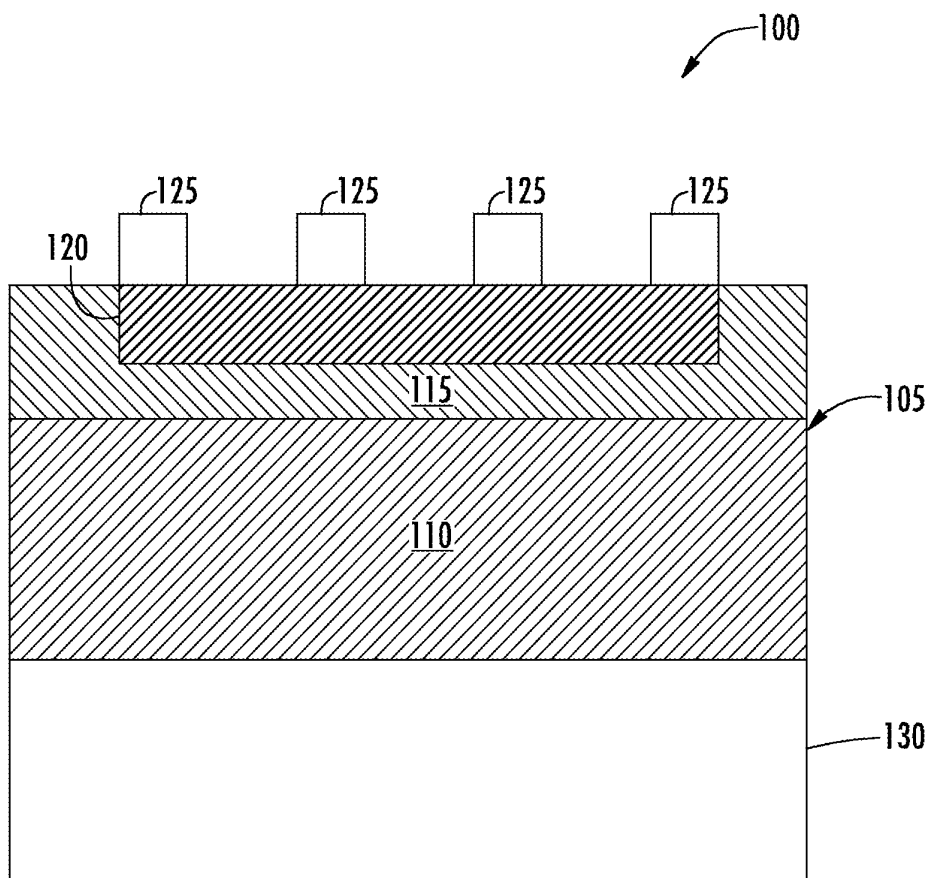

FIG. 1

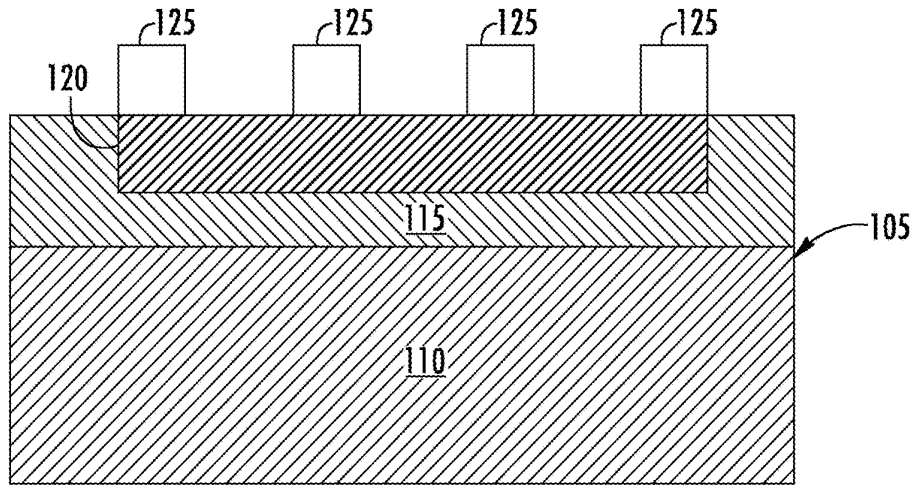

FIG. 2A

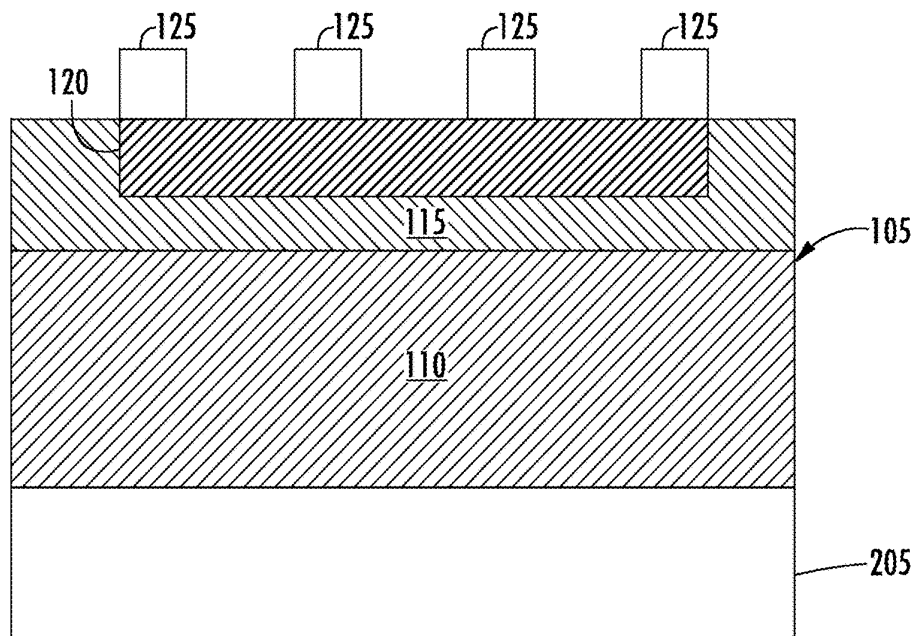

FIG. 2B

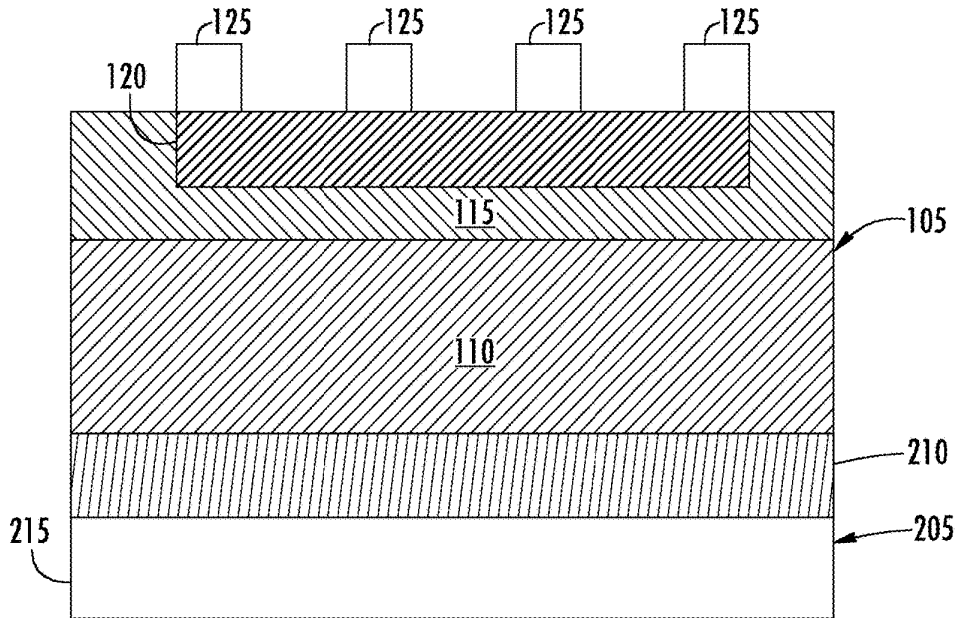

FIG. 2C

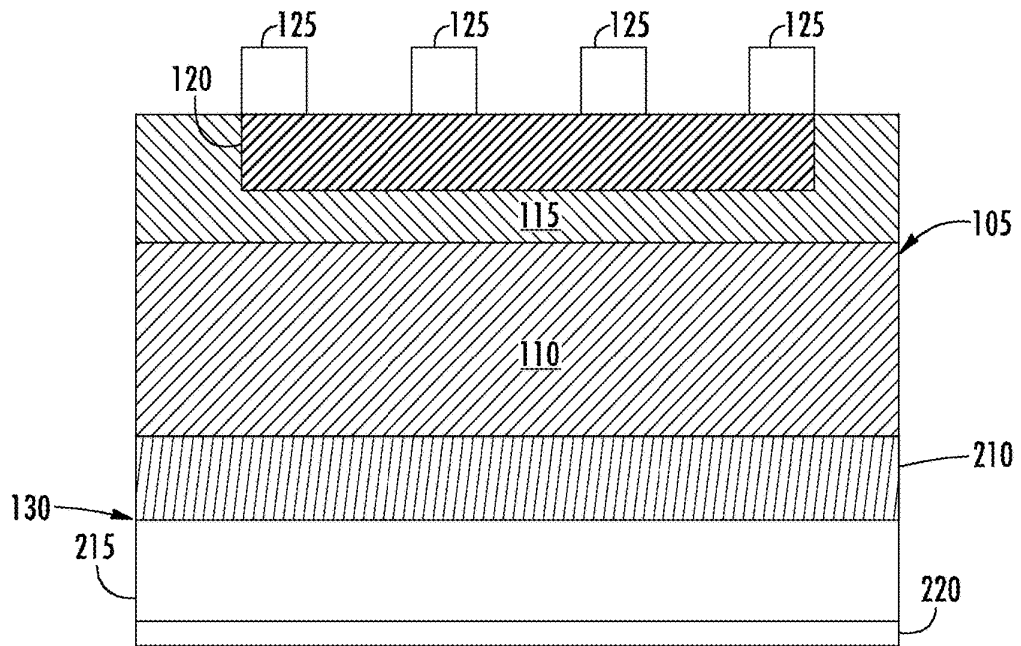

FIG. 2D

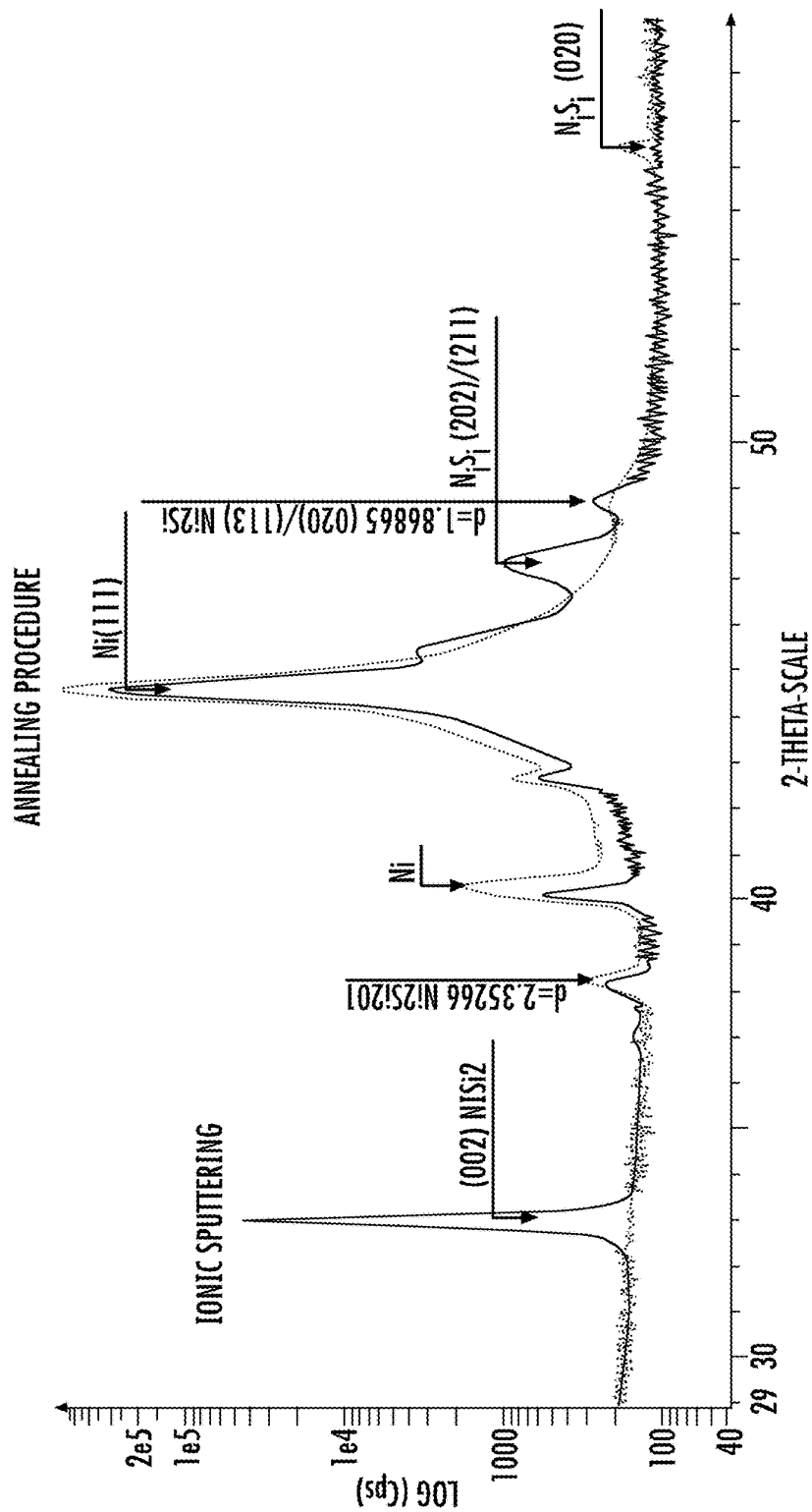

FIG. 3A

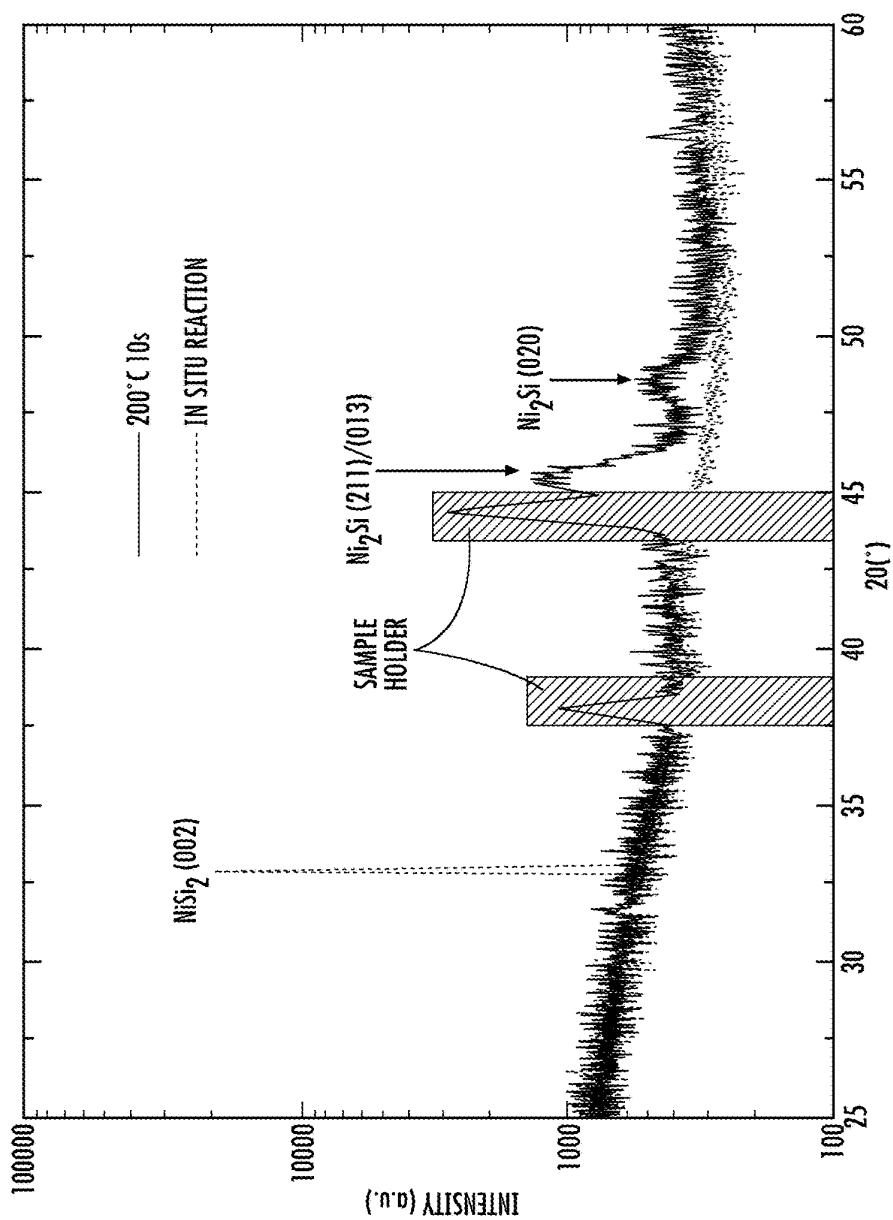

FIG. 3B

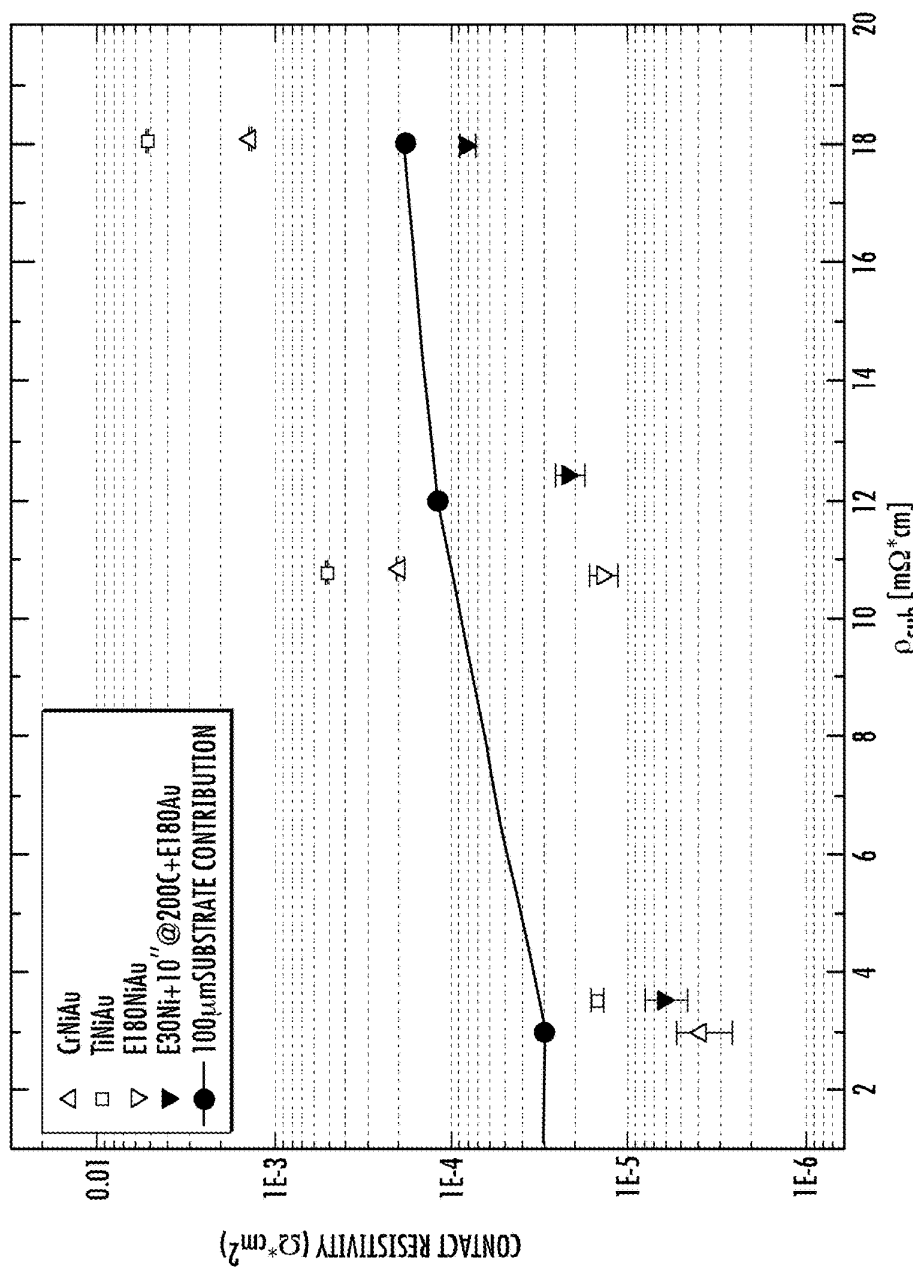

FIG. 4

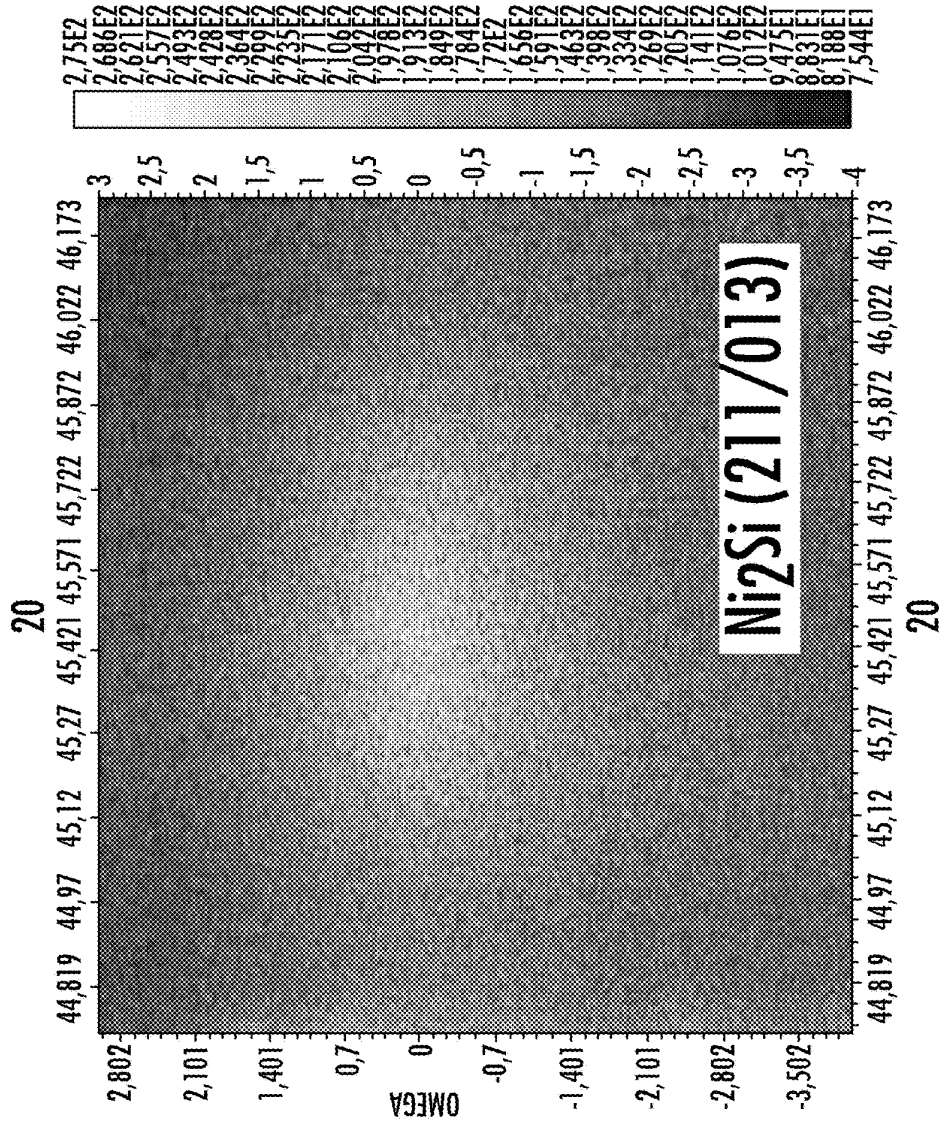

FIG. 5

**INTEGRATED CIRCUITS WITH BACKSIDE
METALIZATION AND PRODUCTION
METHOD THEREOF**

PRIORITY CLAIM

The instant application claims priority to Italian Patent Application No. MI2010A001963, filed Oct. 25, 2010, which application is incorporated herein by reference in its entirety.

TECHNICAL FIELD

One or more embodiments generally relate to integrated devices. More specifically, one or more embodiments relate to terminals of integrated devices.

BACKGROUND

Typically, each integrated device (for example, an integrated electronic device) includes a chip of semiconductor material wherein a corresponding circuit (e.g., an electronic circuit) is integrated for implementing specific functionalities of the integrated device. In particular, a region of the chip is usually used as a substrate of the integrated device, whereas the integrated circuit is formed within at least one functional layer of the chip extending above the substrate (e.g., one or more epitaxial layers); therefore, contact terminals of the integrated circuit are typically made through suitable conductive layers on a front surface of the chip (commonly denoted as front contact terminals), so as to contact the epitaxial layer in which the integrated circuit is formed.

However, some integrated circuits also need contact terminals being formed on a rear surface of the chip (commonly denoted as rear contact terminals), so as to directly contact the substrate. This is the case, for example, for integrated circuits including MOS or BJT transistors for power applications; the latter ones, in fact, have a vertical structure in which a corresponding drain or collector terminal is contacted through the substrate. Moreover, in certain applications, integrated circuits may require rear contact terminals so as to be able to conduct away parasitic leakage currents being originated within the substrate.

In order to form such rear contact terminals, one or more metal layers are typically formed on the rear surface of the substrate, which metal layers are usually generically referred to as backside metallization.

As it is known, backside metallization, although relatively widely used, has some drawbacks that may impair an optimal operation of the corresponding integrated device.

In fact, the substrate and the backside metallization may create a semiconductor-metal junction that forms a corresponding Schottky diode; in order to make such junction ohmic and with a low contact specific resistance (or contact resistivity) (e.g., of the order of several tens of $\mu\Omega\cdot\text{cm}^2$), the substrate is typically formed with a high dopant concentration (e.g., greater than 10^{18} cm^{-3}); in this way, a potential barrier at the interface of the junction is reduced in thickness, thereby facilitating its crossing, via a tunnel effect, by electrical charges. However, an over-doped substrate, in addition to increasing uniformity issues in dopant concentrations between central and side portions of a wafer wherein several integrated circuits are normally formed, may also make difficult the formation of less-doped thin epitaxial layers thereon; moreover, during annealing procedures (e.g., being used to promote a proper reorganization of the reticu-

lar structure and a correct and uniform doping of the substrate), the substrate may consume the epitaxial layer above it, because of an excessive dopant concentration gradient therebetween.

For this reason, a different approach is that of making the backside metallization in a material with such chemical and physical features that allow lowering the contact specific resistance, without substantially needing to increase the dopant concentration within the substrate, assuring limited silicon consumption. However, such material may also have to meet mechanical requirements of good adhesion to the substrate and good solderability with elements external to the integrated device—for example, pins of a package thereof.

For this reason, the solutions being currently used for combining such (electrical and mechanical) requirements provide a composite structure of the backside metallization including different metal layers, each one of which is intended to meet a specific requirement.

For example, in a conventional solution, the backside metallization includes a chromium (or titanium) layer being deposited on the substrate to ensure good adhesion or low contact specific resistance, a nickel layer being deposited on the chromium layer to ensure good solderability, and a gold layer being deposited on the nickel layer for protecting the latter against external contaminations and oxidations, and for improving the solderability of solder elements during welding operations. However, a backside metallization thus implemented may have some drawbacks, mainly due to the need of recurring to trade-off values of dopant concentration within the substrate; in particular, in conditions of relatively high substrate resistivity (e.g., greater than $6\text{ m}\Omega\cdot\text{cm}$, as a result of low dopant concentrations therein), the substrate-chromium layer junction has good adhesion but a high contact specific resistance, whereas in conditions of relatively low substrate resistivity (e.g., lower than $6\text{ m}\Omega\cdot\text{cm}$, as a result of high dopant concentrations), the substrate-chromium layer junction has a low contact specific resistance, but a worse adhesion. Since the trade-off values being chosen for the dopant concentration within the substrate vary according to the performance to be obtained for the integrated device, different variants of the production process may have to be provided; this may imply a relevant logistic and economic effort by a manufacturer of the integrated device, which may imply an increase in the production costs thereof.

In another solution described in WO-A-2008/050251, which is incorporated by reference, the backside metallization includes a gold-silicon eutectic alloy to achieve both a low contact specific resistance and good adhesion. In particular, the eutectic alloy layer is obtained by first depositing a gold layer on the substrate, and then making an appropriate heat treatment, after which the eutectic alloy is placed between a residual gold layer (not involved in the making of the eutectic alloy) and the substrate. Moreover, the backside metallization according to such solution includes a silver layer being deposited on the residual gold layer (for preventing subsequent depositions operations from damaging the eutectic alloy layer), a nickel layer being deposited on the silver layer (for providing good solderability), and a gold (or silver) layer on the nickel layer for protecting the same. Anyway, such a type of backside metallization may involve a significant production complexity and relatively high costs.

SUMMARY

An embodiment is based on the idea of making a coupling layer with the chip directly from the metal layer being used for making the connection to the external elements.

An embodiment is an integrated device including a chip of semiconductor material wherein an integrated circuit is integrated; the integrated device includes a set of contact terminals for contacting the integrated circuit. At least one contact terminal of said set of contact terminals (for example, a rear contact terminal) includes a contact layer of metal material (for example, nickel) being suitable to be directly coupled mechanically (for example, soldered—alone or with the addition of another material that improves its wettability) to an element external to the chip (for example, a pin of a corresponding package), and a coupling element for improving an electrical coupling (for example, a contact specific resistance) and/or mechanical coupling (for example, an adhesion) between the contact layer and the chip. In an embodiment, the coupling element includes a coupling layer being formed by a combination between the metal material of the contact layer and the semiconductor material of the chip, with the coupling layer that is directly coupled to the chip and to the contact layer (for example, an alloy thereof, a chemical compound thereof, and/or an aggregate including at least one chemical compound thereof).

Another embodiment is a corresponding production method of an electronic device.

BRIEF DESCRIPTION OF THE DRAWINGS

One or more embodiments, as well as further features and the advantages thereof, will be best understood with reference to the following detailed description, given purely by way of a non-restrictive indication, to be read in conjunction with the accompanying drawings (wherein corresponding elements are denoted with equal or similar references, and their explanation is not repeated for the sake of exposition brevity). In this respect, it is understood that the figures are not necessarily drawn to scale (with some details that may be exaggerated and/or simplified) and that, unless otherwise indicated, they are simply used to conceptually illustrate the described structures and procedures. In particular:

FIG. 1 schematically shows an integrated device wherein an embodiment may be used;

FIG. 2A-2D schematically show, in front view, some steps of a production process of the integrated device of FIG. 1 according to an embodiment;

FIGS. 3A-3B are quoted diffractograms comparatively showing the composition of a coupling layer being obtained by a production process according to different embodiments, and

FIG. 4 shows a comparative quoted diagram of the value of contact specific resistance as a function of substrate resistivity between conventional solutions and embodiments.

FIG. 5 shows a diagram indicating that, according to an embodiment, the majority of the Nickel is not consumed due to the chemical reaction with Silicon.

DETAILED DESCRIPTION

With particular reference to FIG. 1, it schematically shows an integrated device **100** (e.g., an integrated electronic device) wherein an embodiment may be used. The integrated device **100** is formed in a chip **105** of semiconductor material (e.g. silicon); in particular, the chip **105** includes a support substrate **110** on which at least one functional layer **115** (e.g., one or more epitaxial layers) is formed. An integrated circuit **120** (e.g., an integrated electronic circuit) is formed within the functional layer **115** for

implementing specific functionalities of the integrated device **100**; the integrated circuit **120**, schematically depicted as a generic functional block for simplicity, may include active components (such as transistors) and/or passive components (such as resistors and/or capacitors). The integrated device **100** also includes contact terminals for coupling (mechanically, e.g., by soldering, and electrically) the integrated circuit **120** to elements external to the integrated device **100**—for example, pins of a corresponding package or terminals of another integrated circuit, not shown in the figure. In particular, such contact terminals include front contact terminals **125** (only four shown in the exemplary illustrated embodiment) being formed on a front surface of the chip **105** (defined by a free surface of the functional layer **115**), and a rear contact terminal (or backside metallization) **130** being formed on a rear surface of the chip **105** (defined by a free surface of the substrate **110**); for example, the backside metallization **130** may be used for contacting drain (or collector) terminals of power transistors having a vertical structure, or for collecting, through the substrate **110** and the functional layer **115**, parasitic leakage currents being possibly originated within the integrated circuit **120**.

Turning now to FIG. 2A-2D, they schematically show, in front view, some steps of a production process of the integrated device of FIG. 1 according to an embodiment, with particular attention to aspects relating to the making of its backside metallization.

Starting from FIG. 2A, it schematically shows the integrated device at an intermediate step of the corresponding production process, wherein the integrated circuit **120** has already been formed within the functional layer **115**, and the front contact terminals **125** have already been formed on the chip **105**.

As visible in FIG. 2B, a precursor layer **205** of metal material, e.g., nickel, is formed under the chip **105**. In particular, the precursor layer **205** may be obtained by any deposition process, for example a low rate deposition process (such as a PVD, “Physical Vapor Deposition”, process).

At this point, the structure so far obtained is subject to an annealing procedure, including a heating treatment step at relatively low temperature (e.g., lower than 400° C.), followed by cooling; in an embodiment, the characteristics (e.g., time, rate) of the cooling have little to no impact on the silicide formation]. In particular, the heating treatment step is implemented by inserting the structure into a suitable heating element (not shown in the figure); the latter may be, for example, an ordinary RTP (“Rapid Thermal Processing”) oven, which is able to subject the structure to a desired process temperature in very quick times (e.g., of the order of a few seconds).

After the annealing procedure, as visible in FIG. 2C, a layer **210** is formed that is obtained by a combination of part of the nickel of the precursor layer **205** and a part of the silicon of the substrate **110**. Depending on the process parameters being used, such combination may lead to an alloy (i.e., a solid solution physically homogeneous but chemically heterogeneous), a chemical compound (i.e., a substance formed by elements with a fixed stoichiometric ratio), or an aggregate of chemical compounds that are insoluble between each other and that coexist in the solid phase. But in an embodiment, the nickel reacts with the silicon such that the resulting substance is a chemical compound or an aggregate of chemical compounds. In particular, in an embodiment, during the annealing process respective regions mutually facing the substrate **110** and the precursor layer **205** combine with each other, thereby form-

ing an aggregate of silicide-like compounds (whose stoichiometric ratios depend, for example, on temperature and/or duration of the annealing procedure). For example, the structure is subject to a heating treatment step at a temperature of about 200° C. for a period of about 10 seconds; in this way, a layer 210 is obtained that includes silicide-like compounds mainly in the form of NiSi and in minority quantity in the form of Ni₂Si, and that has a thickness of about 8 nm (by consuming about 4 nm of the precursor layer 205).

As a consequence, at the end of the annealing procedure a large (not combined) residual portion 215 of the precursor layer remains on the layer 210. Such residual portion 215, being of, e.g., nickel, i.e. a material having good solderability properties, is used to be mechanically coupled directly to the external elements (not visible in the figure) of the integrated device—for which in the following it is denoted as contact layer 215. The layer 210, instead, thanks to its chemical and physical properties, improves an electrical and mechanical coupling with the substrate 110 (or in general, with the chip 105)—for which it is denoted as coupling layer 210; in particular, the coupling layer 210 ensures a good adhesion to the substrate 110, and a low contact specific resistance.

The production process continues to FIG. 2D, wherein a gold layer 220 is deposited on the contact layer 215 to protect the latter against external contaminations and oxidations, and to improve the wettability of solder elements during subsequent soldering operations (not shown)—for which in the following it is referred to as coating layer 220. In this way, the coupling layer 210, the contact layer 215, and the coating layer 220 as a whole form the backside metallization 130.

The described embodiment may be advantageous since it does not need to recur to variable values of dopant concentration within the substrate in order to obtain trade-off solutions between good adhesion and low contact specific resistance.

In particular, the described embodiment allows making the coupling layer 210 by using the same material being used for soldering the backside metallization 130 to the external elements (or for other mechanical coupling operations). This implies a considerable degree of simplification of the process of formation of the backside metallization 130 with respect to conventional solutions; in fact, the described embodiment does not need any intermediate layer between the coupling layer 210 and the contact layer 215.

Moreover, the described embodiment involves the execution of a few additional steps, each one of which may be achieved by exploiting techniques or processes already being used for the formation of the functional layer 115, of the integrated circuit 120 and/or of its front contact terminals 125. This involves a significant logistic simplicity by a manufacturer of the integrated device, which implies a cost reduction of the production process, and hence of the integrated device.

As a further improvement, in an embodiment, the annealing procedure is performed before or during the deposition procedure of the precursor layer; for example, such result is achieved by a heating element with which modern PVD apparatus are typically equipped.

In an alternative embodiment, the step of depositing the precursor layer on the substrate is preceded by an in-situ sputter-etch operation with ions of inert gas (e.g., argon ions Ar⁺), hereinafter shortly denoted as ionic sputtering; in this way, the substrate is, at least superficially, cleaned from any possible contaminant agents present on it that might affect a

good quality of the production process. Moreover, the ionic sputtering also has the effect of increasing the substrate temperature to a value such that, approximately as soon as the precursor layer is deposited on it, nickel and silicon combine together approximately immediately and effectively to form the corresponding coupling layer (without the need for any subsequent annealing procedure). In this way, the resulting coupling layer, being obtained approximately simultaneously to the deposition of the precursor layer in a clean and controlled environment, and without extraction in atmosphere, has a structure with a relatively low content of contaminant agents. Moreover, the use of such a procedure may entail the use of a lower number of equipment, with consequent advantage in terms of manufacturing simplicity and costs.

In FIGS. 3A-3B there are shown quoted diffractograms showing the composition, obtained by X-ray analysis using radiant X-rays at an incidence angle of ~0.5°, of the silicides within the coupling layer being obtained both by the annealing procedure and by the ionic sputtering operation. In particular, as visible in such figures, the composition of the coupling layer changes depending on whether it is obtained through the annealing process or the ionic sputtering operation. In the first case, a quite homogeneous structure of the coupling layer is obtained, and includes a prevalence of silicide-like compounds in the form of NiSi, and, in minority amount, in the form of Ni₂Si; in the second case, instead, a less homogeneous structure is obtained including NiSi, with relatively high inclusions of NiSi₂.

From FIGS. 3A-3B it may also be noticed that during the formation process of the coupling layers (i.e., both that obtained by the annealing procedure and that obtained by the ionic sputtering operation), only a small percentage of the nickel precursor layer has been used for obtaining the coupling layer (in the example at issue, about 20 nm out of about 440 nm, corresponding to about 5% of the deposited precursor layer). In this way, sufficient amounts of uncombined nickel (as visible in the same diffractograms) are available to ensure a good quality of the subsequent soldering process.

In FIG. 4 there is shown a comparative quoted diagram of the value of contact specific resistance (in ordinate) as a function of the substrate resistivity (in abscissa), wherein the backside metallization being obtained through the annealing procedure is denoted by the reference E30Ni+10@200 C+E180Au, whereas the backside metallization being obtained through the ionic sputtering operation is denoted by the notation E180NiAu. The contact resistivity has, for both the embodiments above described, lower values than those obtained for backside metallizations being formed by using multilayer structures including chromium or titanium (such as those described in the introductory part of the present description); in this respect, reference is made again to FIG. 4, where in the quoted diagram there are also provided the values of contact specific resistance for the backside metallization including chromium and titanium (denoted by the notations CrNiAu and TiNiAu, respectively).

FIG. 5 shows a diagram indicating that, according to an embodiment, the majority of the Nickel is not consumed due to the chemical reaction with Silicon.

Although one or more embodiments have been described with a certain degree of particularity, it is understood that various omissions, substitutions and changes in the form and details as well as other embodiments are possible. In particular, different embodiments may even be practiced without the specific details (such as the numeric examples) set forth in the preceding description for providing a more

thorough understanding thereof; on the contrary, well known features may have been omitted or simplified in order not to obscure the description with unnecessary particulars. Moreover, it is expressly intended that specific elements and/or method steps described in connection with any disclosed embodiment may be incorporated in any other embodiment as a matter of general design choice.

For example, similar considerations apply if the integrated device has a different structure or includes equivalent components (either separated from each other or combined together, in whole or in part); for example, the backside metallization may have any shape and/or size. In particular, the backside metallization may cover the whole rear surface of the chip, or it may be in the form of different pads (each one for contacting a corresponding or a same pin or any other external element) for particular and specific soldering (or generally contacting) requirements.

Although an embodiment is focused on the backside metallization, it is understood that the same may also be applied for at least one of the front contact terminals of the integrated circuit.

Additionally or alternatively to electrical contact function, the backside metallization may be used as a heat-sink of the integrated device, in order to dissipate the heat generated during its operation. In this respect, it may be possible to provide some variations of the backside metallization in order to ensure thermal performance being appropriate for the application (such as, for example, used material, size, shape, colour, placement, orientation and making and/or assembly modalities).

The contact layer may contribute to the mechanical coupling of the backside metallization in any other way (for example, by soldering or gluing to corresponding pins in wire-bonding, flip-chip technology, and the like). In case of coupling through gluing, the external element to which the contact layer is directly coupled may include, for example, a conductive terminal with an adhesive surface (e.g., obtained by applying a conductive glue or other appropriate material on it).

The combination that gives rise to the coupling layer may include any alloy, including eutectic alloy (i.e., having features proving a single melting point, unlike the classic alloys that typically have a melting range), any single chemical compound, any aggregate of two or more compounds, or any other mixture thereof. In particular, the nature of such combination, as well as characteristics and chemical and physical properties thereof (such as melting point, hardness, etc.) may be chosen, during the design phase, according to technological and economic considerations.

The same considerations may apply if the precursor layer is of a different conductive material, but still suitable for making a mechanically and/or electrically effective coupling layer and a proper contact layer.

The coating layer may also be omitted since it is not necessary; for example, in some applications that are expected to ensure good characteristics in terms of value for money, the external contacts (such as package pins) may be glued directly on the contact layer (however, nothing prevents from making the gluing on the coating layer). Moreover, the coating layer may cover the contact layer only partly, such as, for example, in applications wherein the soldering does not cover entirely the contact layer (whose exposed portions, if uncovered, might be damaged).

Moreover, the coating layer, if provided, may be formed from any other material, such as silver, or it may include a multilayer structure including gold, silver and/or other mate-

rials that allow ensuring efficient wetting/gluing properties in case of soldering/gluing to the external elements.

Moreover, an embodiment lends itself to be implemented through an equivalent method (by using similar steps, removing some steps as being not essential, or adding further optional steps); moreover, the steps may be performed in different order, concurrently, or in an interleaved way (at least partly).

Although the making of the backside metallization has been described as following the making of the integrated circuit (and particularly of its functional terminals), the described method steps may be usefully performed during the formation of the integrated circuit, for example, at least partly in parallel by exploiting common, analogous, or similar process steps.

The values of above for temperature and duration of the annealing process should not be construed restrictively, since they are typically chosen in the design stage, according to technical and economic considerations.

Alternatively, it may be possible to use techniques that provide for depositing the precursor layer on the substrate at a high deposition rate; in this way, the high deposition rate involves an increase of the substrate temperature together with the deposition of the precursor layer.

In any case, the possibility of performing such annealing procedure regardless of the deposition process (also ex-situ) is not excluded.

Nothing prevents from executing the ionic sputtering of the substrate with other inert gases (e.g., helium, neon, krypton, xenon, radon, ununoctium). In addition, the ionic sputtering process may still be followed by another heating treatment (for example, through RTP furnace or heating element of the PVD apparatus), in order to improve the mechanical properties of the coupling layer.

The design of the integrated circuit may also be created in a programming language; moreover, if the designer does not manufacture the electronic devices or the masks, the design may be transmitted by physical means to others. In any case, the resulting integrated circuit may be distributed by its manufacturer in raw wafer form, as a bare die, or in packages. Moreover, the proposed structure may be integrated with other circuits in the same chip, or it may be mounted in intermediate products (such as mother boards) and coupled with one or more other chips (e.g., a controller such as a processor). In any case, the integrated circuit may be suitable to be used in complex systems (such as automotive applications or microcontrollers).

From the foregoing it will be appreciated that, although specific embodiments have been described herein for purposes of illustration, various modifications may be made without deviating from the spirit and scope of the disclosure. Furthermore, where an alternative is disclosed for a particular embodiment, this alternative may also apply to other embodiments even if not specifically stated.

The invention claimed is:

1. An integrated device, comprising:

- a chip of semiconductor material comprising a silicon substrate wherein an integrated circuit is disposed;
- a set of first contact terminals including a first contact layer of a first metal material for contacting the integrated circuit disposed over a first side of the semiconductor material;
- at least one second contact terminal including a second contact layer consisting essentially of nickel disposed over a second side of the semiconductor material and configured to be directly coupled mechanically to an element external to the chip; and

- a coupling layer between the second contact layer and the chip of semiconductor material, said coupling layer comprising a combination of the nickel of the second contact layer and the silicon of the chip of semiconductor material, the coupling layer being directly coupled to the chip of semiconductor material and to the second contact layer and comprising an homogenous aggregate of first and second silicide-like compounds each having a stoichiometric ratio different from each other and consisting essentially of NiSi as a majority quantity and Ni₂Si as a minority quantity and being insoluble to each other and coexisting in the solid phase, wherein the contact resistivity of the coupling layer and second contact layer is above $1 \times 10^{-5.4}$ ohms*cm² and less than $1 \times 10^{-4.3}$ ohms*cm² and the resistivity of the silicon substrate is between 3.5 to 18.0 mohms*cm.
2. The integrated device according to claim 1, wherein the at least one second contact terminal further includes a coating layer for protecting the second contact layer and promoting a wettability thereof.
3. The integrated device according to claim 2, wherein the coating layer includes gold.
4. A semiconductor structure, comprising:
 a substrate comprising silicon;
 a first conductive layer having a plurality of first contact terminals disposed over the substrate;
 a second conductive layer consisting essentially of nickel and having at least one second contact terminal and disposed under the substrate; and
 a coupling layer disposed between the substrate and the second conductive layer and comprising a combination of the nickel of the second contact layer and the silicon of the substrate, the coupling layer being directly coupled to the substrate and to the second conductive layer and comprising an homogenous aggregate of first and second silicide-like compounds each having a stoichiometric ratio different from each other, and consisting essentially of NiSi as a majority quantity and Ni₂Si as a minority quantity and being insoluble to each other and coexisting in the solid phase, wherein the contact resistivity of the coupling layer and second contact layer is above $1 \times 10^{-5.4}$ ohms*cm² and less than $1 \times 10^{-4.3}$ ohms*cm² and the resistivity of the substrate is between 3.5 to 18.0 mohms*cm.
5. The semiconductor structure of claim 4 wherein the coupling layer is in contact with the substrate and second conductive layer.
6. The semiconductor structure of claim 4 wherein the second conductive layer includes an electrical contact.
7. The semiconductor structure of claim 4, further including a conductive coating layer disposed over the second conductive layer.
8. An integrated circuit, comprising:
 a substrate comprising silicon and having a first side and a second side;
 at least a portion of at least one circuit component disposed over the first side of the substrate;
 a first conductive layer having a plurality of first contact terminals disposed over the first side of the substrate;
 a second conductive layer consisting essentially of nickel and having at least one second contact terminal, wherein the second conductive layer is disposed over the second side of the substrate; and

- a coupling layer disposed between the substrate and the second conductive layer and comprising a combination of the nickel of the second contact layer and the semiconductor material, the coupling layer being directly coupled to the substrate and to the second conductive layer and comprising an homogenous aggregate of first and second silicide-like compounds each having a stoichiometric ratio different from each other, and consisting essentially of NiSi as a majority quantity and Ni₂Si as a minority quantity and being insoluble to each other and coexisting in the solid phase, wherein the contact resistivity of the coupling layer and second contact layer is above $1 \times 10^{-5.4}$ ohms*cm² and less than $1 \times 10^{-4.3}$ ohms*cm² and the resistivity of the substrate is between 3.5 to 18.0 mohms*cm.
9. The integrated circuit of claim 8, further comprising a conductive contact disposed over the first side of the substrate.
10. The integrated circuit of claim 8, further comprising: wherein the second conductive layer includes a first contact; and
 a second contact disposed over the first side of the substrate.
11. A system, comprising:
 a first integrated circuit, including:
 a substrate comprising silicon and having a first side and a second side;
 at least a portion of at least one circuit component disposed over the first side of the substrate;
 a first conductive layer having a plurality of first contact terminals disposed over the first side of the substrate;
 a second conductive layer consisting essentially of nickel and having at least one second contact terminal, wherein the second conductive layer is disposed over the second side of the substrate; and
 a coupling layer disposed between the substrate and the second conductive layer and comprising a combination of the nickel of the second contact layer and the semiconductor material of the substrate, the coupling layer being directly coupled to the substrate and to the second conductive layer and comprising an homogenous aggregate of first and second silicide-like compounds each having a stoichiometric ratio different from each other, and consisting essentially of NiSi as a majority quantity and Ni₂Si as a minority quantity and being insoluble to each other and coexisting in the solid phase, wherein the contact resistivity of the coupling layer and second contact layer is above $1 \times 10^{-5.4}$ ohms*cm² and less than $1 \times 10^{-4.3}$ ohms*cm² and the resistivity of the substrate is between 3.5 to 18.0 mohms*cm; and
 a second integrated circuit coupled to the first integrated circuit.
12. The system of claim 11 wherein the first and second integrated circuits are disposed on a same die.
13. The system of claim 11 wherein the first and second integrated circuits are disposed on respective dies.
14. The system of claim 11 wherein one of the first and second integrated circuits includes a controller.
15. The system of claim 11 wherein the first integrated circuit includes a power device.