

29th CIRP Life Cycle Engineering Conference

Energy-Efficient Control of Parallel and Identical Machines: Impact on the Overall Production System

Alberto Loffredo^a, Nicla Frigerio^a, Ettore Lanzarone^{b,c}, Mani Ghassempouri^d, Andrea Matta^a

^aMechanical Engineering Department, Politecnico di Milano, Via G. la Masa 1, 20156, Milan (MI), Italy

^bDepartment of Management, Information and Production Engineering, University of Bergamo, Via Pasubio, 7/B, 24044, Dalmine (BG), Italy

^cInstitute for Applied Mathematics and Information Technologies, National Research Council of Italy (CNR), Via Alfonso Corti 12, 20133, Milan (MI), Italy

^dComau Spa, Via Rivalta, 30, 10095, Grugliasco (TO), Italy

* Corresponding author. Tel.: +39 02 2399 8534. E-mail address: alberto.loffredo@polimi.it

Abstract

Nowadays, manufacturing industries are increasing their interest in the energy-efficiency topic, mostly due to the major environmental impact of machining activities. Manufacturing processes sustainability can be improved by controlling machine state with energy-efficient control (EEC) policies that switch off/on the device. Recently, research demonstrated that this approach can be also applied to a workstation composed of parallel and identical machines, switching off/on each of the devices in the workstation. This paper is focused on this type of configuration, analyzing more identical parallel machines workstations belonging to the same industrial production system from the automotive sector. For all of the studied workstations, a proper EEC policy is identified also considering an availability constraint: in this way, the energy consumption is reduced while a target availability level is satisfied for each station. This work aims to show how the EEC of one or more workstations affects the overall production system in terms of throughput and energy consumption. Discrete event simulation is used to perform numerical analysis and, starting from the experimental results, the benefits of the energy-efficient measures on the overall system are presented and discussed.

© 2022 The Authors. Published by Elsevier B.V.

This is an open access article under the CC BY-NC-ND license (<https://creativecommons.org/licenses/by-nc-nd/4.0>)

Peer-review under responsibility of the scientific committee of the 29th CIRP Life Cycle Engineering Conference.

Keywords: Energy-Efficiency Control; Parallel Machines; Sustainability; Discrete Event Simulation

1. Introduction

The growing interest of companies in enhancing manufacturing processes sustainability is a major trend nowadays. One of the most supported strategies to reduce the environmental impact in manufacturing, according to scientific literature and industries, is the machine state control towards the optimum trade-off between system production rate and energy demand. To achieve this goal, a possible approach can be the energy-efficient control (EEC) of machine tools (“machines” in this work). EEC policies can be also applied to workstations composed of identical machines in parallel, a widely used layout to obtain a balanced production system in terms of workstations workload. This work is focused on this type of configuration. Proper EEC policies are identified for more parallel machines workstations that are part of the same production line. The focus is then moved on the effect that these energy-efficient actions have on the overall production system in terms of throughput and energy consumption. In this way, the industrial impact of

the EEC application in a real system is estimated by running simulation experiments.

1.1. Related Literature

The energy consumption of a machine can be seen as the sum of a *Base Load* portion and a *Load Dependent* part [2]. The former is independent from the process and is required to maintain the machine in ready-for-process conditions; the latter is requested to operate on parts and, therefore, to execute the main machine process. The principal techniques to reduce the *Base Load* energy through machine state control are the EEC and the energy-efficient scheduling (EES). EES and EEC address the control problem from distinct levels. EES is focused on the production activities scheduling, defining production plans aimed to allocate jobs to the machine minimizing the number of non-productive periods and, consequently, decreasing the energy consumption. A complete EES literature review can be found in [6]. On the other hand, EEC provides policies to be applied in real-time during production progress, without de-

terministic information on the next part arrival to the machine. This works deal with EEC. EEC policies aim at switching off the machine during idle periods (i.e. when the part flow is interrupted and the machine is not operating on parts) and to reactivate the device only when it has to be ready before the arrival of a part. In this way, the *Base Load* energy can be reduced. A proper EEC policy should decrease energy consumption while assuring a target machine availability level, i.e. a target production rate: indeed, the machine can process parts only when available. EEC policies represent a green alternative to the so-called *Always-on* policy, where the machine is kept in ready-for-process conditions even during idle periods. Nevertheless, the *Always-on* is by far the most commonly-used management policy for machines in manufacturing.

In recent years, research efforts focused on the EEC of manufacturing equipment. It is possible to find several works dealing with the EEC of a single workstation composed of a single buffer and a single machine (examples in [3],[5],[9],[10]). However, in this case the problem is addressed controlling the stand-alone station without focusing on its interactions with the shop floor. Looking at the entire production line, modeled as a sequence of single-buffer-single-machine workstations, examples of EEC policies for the overall manufacturing system can be found in [1],[4],[8],[13]. Nevertheless, in all these works on the EEC in manufacturing, the identical parallel machines configuration is never considered as the system to be controlled in an energy-efficient way. A different approach can be found modeling the identical parallel machines as a M/M/c queue. This methodology was used to find several control policies for M/M/c systems operating in data-centers (examples in [7], [12], [14]). However, all the works on data-centers are characterized by assumptions not properly aligned with manufacturing sector, as part processing that can be interrupted: the extracted properties and policies might be not suitable for manufacturing systems. Finally, in recent literature it is possible to identify one work, related to the manufacturing field, providing a model leading to EEC policies for a workstation composed of an upstream buffer and multiple identical parallel machines working on a single part type ([11]). The control is executed with buffer level information. This model also takes into account an availability constraint. For this reason, the extracted EEC policy leads to the reduction of the workstation energy consumption while satisfying a target level on the system availability. However, this work was limited to the study of the stand-alone workstation without analyzing how controlling such a workstation with an EEC policy affects the overall production line.

1.2. Contribution

The study of EEC in manufacturing is becoming increasingly important, given the need to improve industrial processes sustainability. In particular, identical parallel machines configuration is widely used in manufacturing field and, for this reason, being able to reduce the environmental impact of such a workstation can be considered a main target to achieve. Nevertheless, in literature there is only work addressing the EEC approach for the parallel machines configuration but, even in this

case, the interactions with the shop floor are not considered. To fill this gap, this work analyzes the impact that implementing EEC policies to one or more parallel machines workstations has on the overall production system, in terms of throughput and energy consumption. The impact is evaluated in a real case of manufacturing system from the automotive sector. Suitable EEC policies are identified for two different parallel machines workstations part of this production line. The EEC policies are computed with an existing model present in literature ([11]).

The remainder of the paper is organized as follows. Section 2 describes the framework used for the performed analysis. Section 3 presents an overview on the model used to identify the EEC policies for the workstations to be controlled. Section 4 includes a description of the industrial case studied in this work. A numerical analysis is reported in Section 5, showing the effects on the overall production line when the aforementioned EEC policies are implemented. Conclusions and further developments are discussed in Section 6.

2. Framework Used for the Analysis

To assess how the EEC of parallel machines workstations affects the performance of a real production system, analysis are performed with the following framework:

- Step 1: The workstations to be controlled are selected.
- Step 2: For each of them, a suitable EEC policy is identified with a model taken from literature ([11]). The latter is implemented with *Matlab (Mathworks, US)* software. This model is limited: it considers each workstation as stand-alone, without taking into account the interactions with the shop floor.
- Step 3: Once the policies are identified, discrete event simulation is used to estimate the system behaviour in different scenarios, where the EEC is implemented on one or more of the selected workstations. The simulation software utilized is *Arena (Rockwell Automation, US)*.
- Step 4: Numerical results are compared with the performance of the system as-is, assessing the EEC impact on the system.

3. Energy-Efficient Control Policies Identification Model

The model used in this work to identify proper EEC policies for the parallel machines workstations under investigation is taken from literature ([11]). The model analyzes workstations composed of a common upstream buffer with finite capacity K , followed by c identical parallel machines. All the c machines are consistent with the energetic state model that follows, visible in Figure 1. Parts arrive to the common upstream buffer following a stochastic process with rate λ . The machine is *busy* (b) while working on parts with stochastic processing times with rate μ ; on the other hand, it is *idle* (i) when it is in ready-for-process conditions but it is not operating on parts. *Busy* and *idle*

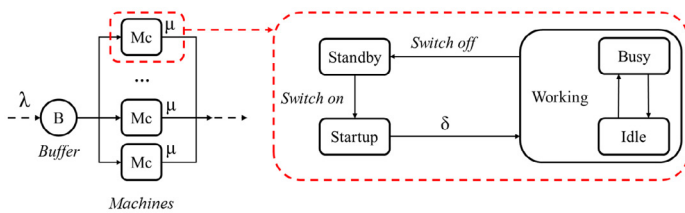

Fig. 1. State model of the parallel machines workstation under analysis [11].

are two sub-states composing the *working* (w) state. From the *working* state, the machine can be switched off instantaneously going into the *standby* (sb) state: a lower power request state where only emergency services are active, so that the machine cannot process parts and the service is interrupted. From the *standby* state, the machine must go through the *startup* (su) state to come back in *working* state: a stochastic startup time with rate δ is required to resume inactive components. It is also possible to define w_s , the constant power consumption characterizing each machine state $s = \{w, sb, su\}$. In this case, w_w depends on the power requested in the two sub-states i and b (w_i and w_b , respectively); moreover, $w_b > w_i > w_{sb} \approx 0$ and $w_{su} > w_i$. An additional power consumption is required for holding parts in the upstream buffer: w_h . In addition to these workstation parameters, the model takes also into account a target workstation availability level to be satisfied. This type of constraint is imposed to not jeopardize the production rate. The target availability is represented with the continuous variable $u_{target} \in [0, 100\%]$: $u_{target} = 0\%$ if all the c machines are always switched off and $u_{target} = 100\%$ if all the c machines are always switched on.

Once all the cited parameters are defined, the EEC problem for a parallel machines workstation can be formalized as a Discrete Time Markov Decision Process (DT-MDP). To deal with a DT-MDP, a uniform transition rate, ν , and a discount factor, $0 < \rho < 1$, are also required. Dynamic programming methodology is used to solve the DT-MDP problem: the identified solution corresponds to the EEC policy reducing the expected total discounted energy cost over an infinite horizon considering the stand-alone workstation. The EEC policy applies a switch off/on approach to the identical parallel machines in the workstation while satisfying a target availability level.

4. System Description

The industrial system under investigation is a manufacturing system producing cylinder heads in the automotive sector (Figure 2). In the production line, parts are carried on pallets and pallets are carried by a conveyor connecting all the workstations. The number of pallets circulating in the system is fixed and constant. The production process consists of twenty-one total operations performed by automated equipment. In particular, four of these operations are machining operations (Op.125, 375, 390 and 525). All the system devices are unreliable and have deterministic processing time. Machines Time To Failure (TTF) and Time To Repair (TTR) are all stochastic and it is as-

sumed that they follow the exponential distribution. First come first serve and blocking after service rules are applied. All the buffers have finite capacity.

Workstations performing Op.125 and Op.525 are identical and, in this study, the EEC is implemented on these two workstations. Both workstations are composed of 6 identical parallel machines with a common upstream finite capacity buffer, respectively B2 and B15. Both buffers have the same capacity, K , equal to 10 and the same holding power consumption, w_h , equal to 0.75 kW per held part. Being Op.125 and Op.525 identical, they are characterized by the same parameters. Each machine, in working state is characterized by w_b and w_i equal to, respectively 15 and 9.30 kW; the startup state has an associated power consumption, w_{su} , of 10 kW and the standby state generates a null power request w_{sb} . In addition, for each machine, the mean processing time is equal to 200 seconds, according to the production system design, and the mean startup time is equal to 30 seconds, according to the machine characteristics. The mean part arrival time to the buffer is equal to 42 seconds, corresponding to the target system production time for one part. The corresponding rates μ , δ , and λ , are equal, respectively, to 0.005, 0.03 and 0.024. All these data are provided by the company owning the industrial system under study. The remaining production system parameters are not reported because of a confidentiality agreement with the company.

5. Numerical Experiments

5.1. Scenarios Analyzed

To assess the impact that the EEC on one or more parallel machines workstations has on the overall production system, suitable EEC policies are identified and applied to Op.125 and Op.525. In particular, seven scenarios are studied (Table 1). Scenario 1 represents the base case, i.e. system without any EEC policy implemented, where the *Always-on* policy is applied on Op.125 and Op.525. Scenario 1 is used as benchmark to compare the performance of the system as-is with the cases where EEC is implemented on one or more workstations. In Scenarios 2 and 3 only Op.125 is controlled, but varying the target availability level to be guaranteed for that workstation (from 75% to 80%). In these cases, the *Always-on* policy is applied to Op.525. The reverse situation is represented by scenarios 4 and 5, where Op.525 is controlled, but with two distinct target availability levels (75% and 80%) and Op.125 is subject to the *Always-on* policy. Finally, in scenarios 6 and 7, both workstations are controlled, but with increasing u_{target} in the two situations (still from 75% to 80%). In all the cases, the *Always-on* policy is implemented on all the other system devices. Numerical experiments are conducted with discrete event simulation.

5.2. EEC Policies Computation

As reported in Section 3, to apply the literature model and obtain a suitable EEC policy for one parallel machines workstation, it is required to define the following inputs: the work-

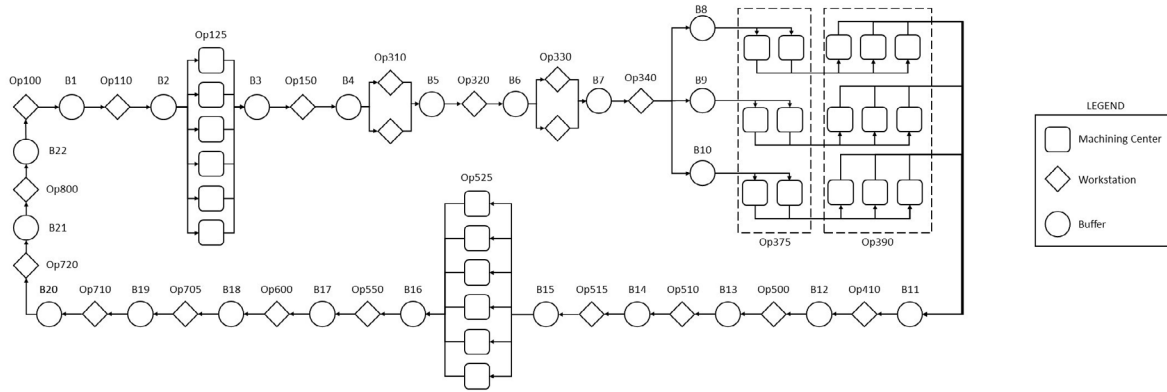

Fig. 2. Layout of the industrial system under investigation.

Table 1. Scenarios analyzed.

Scenario Number	EEC Policy on Op.125	u_{target} for Op.125	EEC Policy on Op.525	u_{target} for Op.525
1	No	-	No	-
2	Yes	75%	No	-
3	Yes	80%	No	-
4	No	-	Yes	75%
5	No	-	Yes	80%
6	Yes	75%	No	75%
7	Yes	80%	No	80%

station parameters, a discount factor ρ , a uniform transition rate ν and the target availability level u_{target} . However, in all the scenarios, ρ and ν do not vary: they are fixed and equal, respectively, to 0.80 and 0.25. Moreover, also the workstation parameters for Op.125 and Op.525 do not vary: they are fixed and identical for both of them in each scenario (see Section 4). Thus, the only varying parameter for both workstations in the different scenarios is u_{target} . Nevertheless, Op.125 and Op.525 are subject to the same two u_{target} values and this leads to two different EEC policies:

- Policy π_{75} when u_{target} is equal to 75%. To be applied to Op.125 in Scenario 2 and 6, and to Op.525 in Scenario 4 and 6.
- Policy π_{80} when u_{target} is equal to 80%. To be applied to Op.125 in Scenario 3 and 7, and to Op.525 in Scenario 5 and 6.

Thus, once all the fixed input parameters are defined, the model can be implemented twice: one for each different u_{target} value. In this way, the aforementioned EEC policies are obtained and presented in Table 2. The control is executed using buffer level information: each policy indicates, for each possible upstream buffer level n , the corresponding number of machines in the station that should be switched on: a_n . As an example, π_{75} indicates that whenever the upstream buffer level n is equal to 4, in Op.125 (or Op.525) five machines must be switched

on ($a_{n=4} = a_4 = 5$) and one machine must be switched off ($c - a_4 = 1$).

Table 2. EEC policies π_{75} and π_{80} for Op.125 and Op.525 in the industrial case under investigation.

Policy	n :	0	1	2	3	4	5, ..., 10
π_{75}	a_n :	0	1	2	3	5	6
π_{80}	a_n :	0	1	2	4	6	6

5.3. Simulation Model Parameters

The simulation model is consistent with the system described in Section 4. Given the presence of stochastic parameters as TTR and TTF for each system device, also the simulation model is stochastic. Thus, the target parameters of the analysis, i.e. the system throughput and the energy consumption of Op.125 and Op.525, are random variables. Because of that, for each scenario, the experiment is replicated for a fixed number of times, equal to 10, and all the target parameters are extracted with a 95% confidence level on the respective mean value. All the experiments are performed with an effective simulation length of 50 weeks, considering 127 hours per week: the total duration corresponds to one year of production time. The same transient period is imposed for each experiment, equal to 30 days of production period: this represents an overestimation, for computational-accuracy reasons, of the transient period identified with the Welch method ([15]).

5.4. Experimental Results

Experimental results of scenarios from 2 to 7 are then compared to scenario 1, to assess the impact at system level of the EEC application on Op.125 and Op.525. Results are reported in Table 3 for the throughput variation, and in Table 4 for the resulting energy saving. In addition, a comprehensive overview is provided in Figure 3.

In all the scenarios, the EEC implementation always significantly reduces the energy consumption. However, in scenarios 2, 4 and 6, where π_{75} is applied to Op.125 and/or Op.525, a

Table 3. Impact of the EEC policies application on the industrial system daily throughput, all the scenarios are compared to the base case (scenario 1).

Scenario Number	Throughput [Parts/Day]	Throughput Loss in respect to the base case [%]
1	1445.09 ± 2.12	-
2	1434.30 ± 2.05	0.75 ± 0.16
3	1445.03 ± 0.77	0
4	1430.08 ± 1.04	1.04 ± 0.10
5	1444.94 ± 1.56	0
6	1427.85 ± 2.89	1.19 ± 0.21
7	1446.25 ± 0.85	0

Table 4. Impact of the EEC policies application on the daily comprehensive energy consumption of Op.125 and Op.525, all the scenarios are compared to the base case (scenario 1).

Scenario Number	Energy Consumption for Op.125 and Op.525 [kWh in one day]	Energy Saving in respect to the base case [%]
1	3137.82 ± 1.85	-
2	3009.38 ± 2.67	4.09 ± 0.10
3	3080.81 ± 1.89	1.82 ± 0.08
4	3018.62 ± 2.06	3.80 ± 0.19
5	3098.38 ± 2.97	1.26 ± 0.20
6	2908.82 ± 3.48	7.30 ± 0.21
7	2955.47 ± 3.10	5.81 ± 0.17

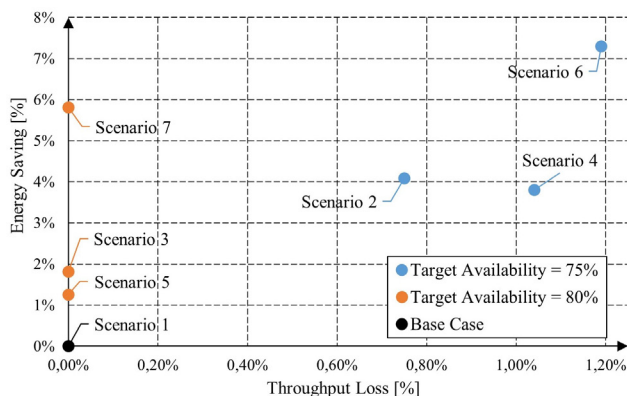

Fig. 3. Impact of the EEC policies application industrial case under investigation, all the scenarios are compared to the base case (Scenario 1).

slight productivity reduction is present. The u_{target} associated to π_{75} is not very high and, for this reason, the workstations with π_{75} applied are characterized by machines frequently switched off. This leads to a great improvement regarding the process sustainability in respect to the base case but, being the corresponding u_{target} not excessive, there is a throughput loss. On the other hand, the u_{target} associated to π_{80} is higher and the workstations with π_{80} applied are characterized by higher availability, i.e. higher productivity: this leads to a null throughput loss while the energy saving is lower but still significant, as in scenarios 3, 5 and 7. To conclude: when the only varied setting is the increasing u_{target} requested, the energy saving decreases but the throughput loss is reduced to null. Furthermore, the EEC

implementation on two workstations always leads to a major reduction on the energy consumption: scenarios 6 and 7, indeed, are characterized by higher energy saving than the other cases. Finally, scenario 7 can be identified as the best and preferable option to be realized in the industrial system under study: this configuration is the one with the highest energy saving among the cases with null throughput loss. Indeed, if u_{target} is progressively reduced from scenario 7, both the throughput loss and the energy saving will gradually increase, as in scenario 6. Therefore, although it is possible to achieve larger energy savings, this will also lead to higher productivity drops. The results confirm that, even applying an EEC policy to only one workstation, the corresponding benefits in terms of environmental impact are relevant. In addition, through a trade-off between system production rate and energy demand, it is possible to select properly the target workstation availability and choose if it is preferable to decrease more the energy consumption, but causing a productivity reduction, or to maintain the same production level and anyway reduce the workstation energy use. Moreover, the more the EEC is executed in the production system, the higher the benefits in terms of environmental impact.

5.5. Detailed analysis of Scenarios 6 and 7

Scenarios 6 and 7 are characterized by the highest energy saving values. Hence, it is interesting to understand how the EEC policies modify the operation of Op.125 and Op.525 in these cases. In Figure 4, the percentages of time that each controlled workstation spends with a certain number of switched on machines in both scenarios are reported. Trivially, when the *Always-on* policy is applied on Op.125 and Op.525 as in scenario 1, all the 6 machines in the workstations are always switched on. On the other hand, when π_{80} is applied (scenario 7, Figure 4-(a)), the amount of time in which all the 6 machines in the workstation are switched on is decreased. Moreover, for a consistent amount of time only 2 or 4 machines are switched on and, in addition, for small periods there is even only 1 or 0 switched on machines. Finally, it never occurs to have exactly 3 or 5 switched on machines, since in $\pi_{80} a_n$ is never equal to 3 or 5. This different workstation functioning leads to the energy saving observed in Table 4, although it has no effects on the system throughput. A different situation can be observed when π_{75} is implemented (scenario 6, Figure 4-(b)). The amount of time spent with 6 switched on machines is further reduced while for long periods the workstations operates with 2, 3 or 5 switched on machines and, for small periods, Op.125 and Op.525 work with only 1 or 0 switched on machines. Finally, being a_n never equal to 4 according to π_{75} , the workstations never has exactly 4 switched on machines. This behavior of the two workstations leads to a higher energy saving than in scenario 7, but also causes a throughput loss.

5.6. Deviations from the Literature Model

It is interesting to analyze the differences from the expected results provided by the literature model and the actual results from simulation. In scenario 7, used as reference case, policy

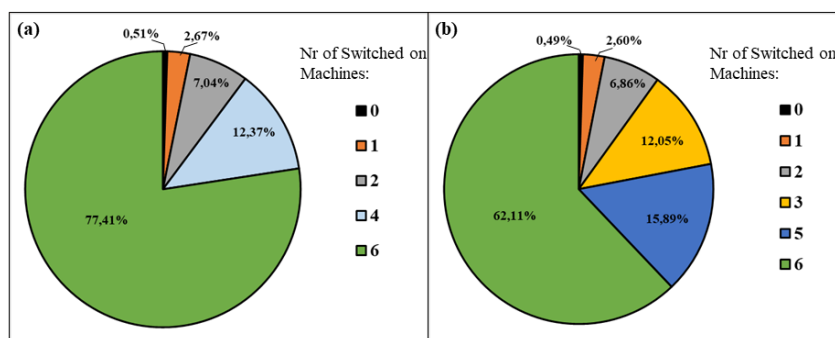

Fig. 4. Percentages of time in which a specific number of machines are switched on in Op.125 and Op.525 in scenario 7 (a) and scenario 6 (b).

π_{80} is applied to both Op.125 and Op.525. When computing π_{80} , the DT-MDP model also estimates the resulting energy saving when the policy is implemented. For both workstations, this value is equal to 7.52%, slightly higher than the simulation result ($5.81 \pm 0.17\%$). This discrepancy can be explained looking at the interactions with the production system. The model, indeed, assumes that there is an infinite capacity buffer downstream the workstation to be controlled: machines cannot be blocked and processed parts can leave immediately the workstation. Thus, if a machine should be switched off after the process completion, the switch off transition is immediate and the device decreases its energy consumption right away. However, in the real case all buffers have finite capacity and machines can be blocked: when this happens, processed parts cannot leave the workstation until the respective downstream buffer is no longer full. During this blocking period, even though a machine should be switched off after the process completion, it remains in working state and continues to consume energy. This different behaviour caused by the blocking phenomenon leads to higher energy consumption than expected to the consequent deviations between the estimated and the actual results.

6. Conclusions and Further Developments

In this work, an EEC policy based on buffer level information has been applied to more identical parallel machines workstation used in manufacturing field. Afterwards, it has been studied the impact that this energy-efficiency action has on the entire production line. Numerical results are presented, showing the corresponding benefits when the policy is applied to one or more workstations pertaining to a real industrial system from the automotive sector. The EEC policies always lead to significant reduction in terms of energy consumption. Moreover, with an appropriate selection of the target workstation availability level to be satisfied, it is possible to decrease the energy use without jeopardizing the production rate. Finally, the more workstations are controlled in an energy-efficient way, the higher the impact in terms of energy saving.

To extend this work, an interesting study could be performed controlling more workstations in the production systems and, consequently, analyzing more scenarios where the EEC impacts in different ways on the system. Finally, a challenging topic might be the creation of a novel model leading to a unique EEC

policy for the overall production system, where the control is executed jointly in all the workstations, considering the overall system state in each control action.

References

- [1] Brundage, M.P., Chang, Q., Li, Y., Xiao, G., Arinez, J., 2013. Energy efficiency management of an integrated serial production line and hvac system. *IEEE transactions on automation science and engineering* 11, 789–797.
- [2] Dahmus, J.B., Gutowski, T.G., 2004. An environmental analysis of machining, in: *ASME international mechanical engineering congress and exposition*, pp. 643–652.
- [3] Frigerio, N., Matta, A., 2014. Energy efficient control strategy for machine tools with stochastic arrivals and time dependent warm-up. *Procedia CIRP* 15, 56–61.
- [4] Frigerio, N., Matta, A., 2015a. Analysis of an energy oriented switching control of production lines. *Procedia CIRP* 29, 34–39.
- [5] Frigerio, N., Matta, A., 2015b. Analysis on energy efficient switching of machine tool with stochastic arrivals and buffer information. *IEEE Transactions on Automation Science and Engineering* 13, 238–246.
- [6] Gahm, C., Denz, F., Dirr, M., Tuma, A., 2016. Energy-efficient scheduling in manufacturing companies: A review and research framework. *European Journal of Operational Research* 248, 744–757.
- [7] Gandhi, A., Harchol-Balter, M., Adan, I., 2010. Server farms with setup costs. *Performance Evaluation* 67, 1123–1138.
- [8] Huang, J., Chang, Q., Arinez, J., Xiao, G., 2019. A maintenance and energy saving joint control scheme for sustainable manufacturing systems. *Procedia CIRP* 80, 263–268.
- [9] Jia, Z., Zhang, L., Arinez, J., Xiao, G., 2016. Performance analysis for serial production lines with bernoulli machines and real-time wip-based machine switch-on/off control. *International Journal of Production Research* 54, 6285–6301.
- [10] Li, W., Zein, A., Kara, S., Herrmann, C., 2011. An investigation into fixed energy consumption of machine tools. *Proceedings of the 18th CIRP International Conference on Life Cycle Engineering*, 268–273.
- [11] Loffredo, A., Frigerio, N., Lanzarone, E., Matta, A., 2021. Energy-efficient control policy for parallel and identical machines with availability constraint. *IEEE Robotics and Automation Letters*.
- [12] Maccio, V.J., Down, D.G., 2018. Asymptotic performance of energy-aware multiserver queueing systems with setup times, in: *2018 Annual American Control Conference (ACC)*, IEEE, pp. 6266–6272.
- [13] Su, H., Frigerio, N., Matta, A., 2016. Energy saving opportunities and value of information: a trade-off in a production line. *Procedia CIRP* 48, 301–306.
- [14] Szarkowicz, D.S., Knowles, T.W., 1985. Optimal control of an M/M/s queueing system. *Operations research* 33, 644–660.
- [15] Welch, P.D., 1983. The statistical analysis of simulation results. *The computer performance modeling handbook* 22, 268–328.