

# EXPERIMENTAL CHARACTERIZATION OF THE INNOVATIVE RADIAL CONNECTION SYSTEM

Paolo Grossi<sup>1</sup>, Riccardo Fanti<sup>2</sup>, Andrea Polastri<sup>3</sup>, Ernesto Callegari<sup>4</sup>, Hans J. Blaß<sup>5</sup>

**ABSTRACT:** The mechanical behavior of an innovative connector named RADIAL was investigated by means of an extensive experimental campaign. An analytical calculation method was developed based on experimental results. A series of monotonic tests in tensile, compression, and in-plane shear configuration were performed on three different typologies of connectors (named RADIAL90, RADIAL60D and RADIAL60S). RADIAL consists of a semi-circular shaped steel element with one or two welded steel flanges. The connector must be screwed in a proper hole made in timber element (e.g. glulam or cross laminated timber). The screws are radially arranged and are subjected primarily to tensile forces. RADIAL elements may be used as panel-to-panel joints or as anchor point for cross laminated timber panel as well as the central hinged connection between two glulam/solid wood elements (e.g. roof trusses). Results showed that all three typologies of RADIAL are characterized by high resistance and stiffness in different load configurations. An overview of the tests is presented in this paper.

**KEYWORDS:** timber connections, multi-directional connections, experimental tests, prefabrication, DfD.

## 1 – INTRODUCTION

The timber construction industry, especially for mass timber structural systems (e.g. cross laminated timber-CLT), heavily relies on connections installed on-site. While factory installation offers several advantages, connections installed on-site still dominate the market for various reasons. Key factors include the management of installation and assembly tolerances, as well as logistical considerations tied to production facilities. In many projects, manufacturers opt to ship panels with standard processing, leaving the installation of connectors to the customers. This decision helps reduce storage and handling costs and allows the use of connections with a lower unit price. However, it also leads to significant inefficiencies in the construction process. In recent years, several factors have emerged that are driving the shift toward fully or partially prefabricated systems. A multidisciplinary approach plays a crucial role in the success of this evolution. From a technical standpoint, installation in a controlled environment ensures better

quality control and minimizes risk. Addressing these inefficiencies can lead to substantial savings in construction site management, such as costs related to equipment rentals and worker transfers. During the design phase, the use of new RADIAL connectors can serve as an additional guarantee for the system's proper functioning, as well as ease of assembly and disassembly. This is a key point in hybrid structural systems where a high levels of optimization and performance demand specialized solutions.

## 2 – CONNECTOR DESCRIPTION

RADIAL was engineered to transfer shear and tensile forces; three different typologies of connector were developed: RADIAL90 and RADIAL60D/S characterized by a diameter D equal to 89 and 60mm, respectively. Two steel flanges are welded to RADIAL90 and RADIAL60D while RADIAL60S has only one flange, as shown in Fig. 1.

---

<sup>1</sup> Paolo Grossi, Rotho Blaas srl, Cortaccia/Kurtatsch, Italy, paolo.grossi@rothoblaas.com

<sup>2</sup> Riccardo Fanti, Institute for Bioeconomy-National Research Council of Italy (CNR-IBE), San Michele all'Adige, Italy, riccardo.fanti@ibe.cnr.it

<sup>3</sup> Andrea Polastri, Institute for Bioeconomy-National Research Council of Italy (CNR-IBE), San Michele all'Adige, Italy, andrea.polastri@ibe.cnr.it

<sup>4</sup> Ernesto Callegari, Rotho Blaas srl, Cortaccia/Kurtatsch, Italy, ernesto.callegari@rothoblaas.com

<sup>5</sup> Hans Joachim Blaß, BE Ingenieure GmbH, Karlsruhe, Germany, blass@be-ingenieure.com

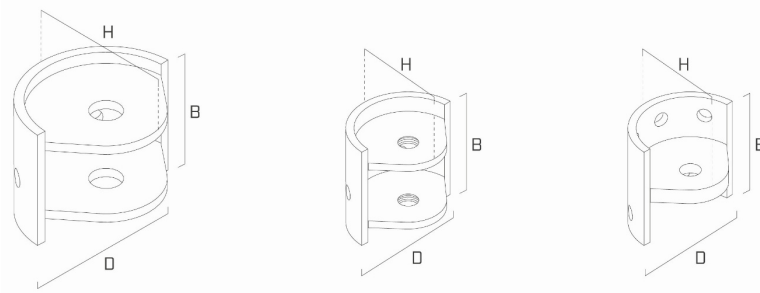

Figure 1. RADIAL connectors: RADIAL90 (left), RADIAL60D (centre) and RADIAL60S (right)

Geometric parameters are reported in table 1 according to Fig. 1 ( $t_c$  and  $t_f$  indicate the thickness of the semi-circular steel plate and flanges, respectively). All the connectors are made with S355 steel grade according to EN10025 standard. Partial (4 screws) or full (6 screws) pattern of radially arranged fasteners (Fig. 2) can be used for each connector. Fully-threaded VGS screws [1] must be installed to fix RADIAL90 (Fig. 1, left) to timber element while fully-threaded LBSH (or LBS) screws [1] for RADIAL60D and RADIAL60S (Fig. 1, centre and right, respectively). RADIAL is connected on the other side (steel) with M16 (RADIAL90) or M12 (RADIAL60D and RADIAL60S) bolt.

Table 1: Geometric properties of RADIAL connectors

Connector	D [mm]	H [mm]	B [mm]	$t_c$ [mm]	$t_f$ [mm]	Screws [-]
RADIAL90	89	74	65	5	5	VGS Ø9
RADIAL60D	60	49	55	4	4	LBSH Ø7
RADIAL60S	60	49	55	4	8	LBSH Ø7

An individual connector can be directly coupled with another as shown in Fig. 2 (left). Additionally, a special coupling kit, named RADIALKIT (U-shape steel plates/forks) was developed for spaced connection (only tensile forces, Fig. 2, centre). Also RADIAL can be used as anchor system for bracing elements (Fig. 2, right). Configuration with two connectors installed side by side is adopted to increase resistance and stiffness of joint. This versatility allows RADIAL and RADIALKIT to effectively replace "tie down" connections in platform type constructions. RADIAL is also suitable as a connection system between walls and foundations or with steel structures, for both shear and tensile loads. Additional connection plates can be designed to meet seismic design requirements according to capacity design principles, ensuring, through proper design, ductile failure modes, while considering the RADIAL connectors as over-resistant elements. The potential of the system, particularly in the spaced configuration, lies in the fast assembly process, facilitated by the large tolerances and the reduced number of connectors required.

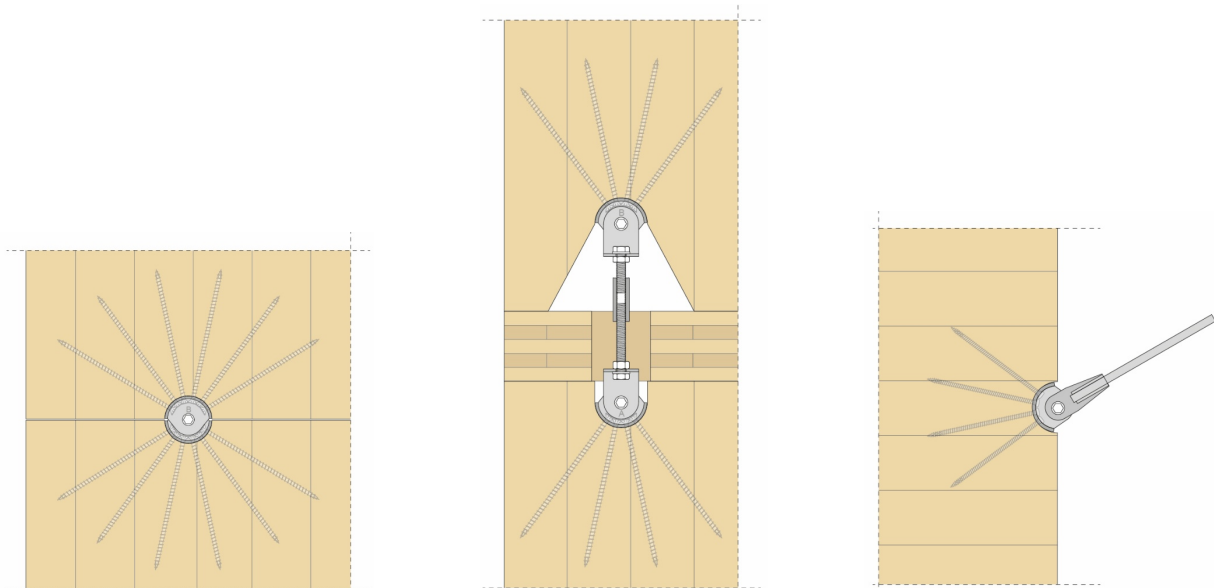

Figure 2. RADIAL connectors: direct coupling (left), coupling with RADIALKIT (centre) and anchoring system for bracing elements (right)

### 3 – EXPERIMENTAL SETUP

The first prototype of RADIAL characterized by an external diameter equal to 89mm was presented and tested in [2]. After a preliminary experimental campaign conducted to optimize the shape/thicknesses of RADIAL prototypes and typology/number/position of screws, the final versions were chosen (three different typologies). In order to provide a calculation method and design values to practitioners, the experimental results were used to apply for a European Technical Assessment (ETA) [3] following the procedure (calculation assisted by testing) of the European Assessment Document (EAD) for three-dimensional nailing plates [4]. An extensive experimental campaign was carried out on new RADIAL connection systems; the aim was the full characterization of multi-directional monotonic behaviour, according to EN26891:1991 [5]. Special setups were developed for testing RADIAL in tensile (F1T), compression (F1C) and in-plane shear (F2/3) load configuration; in case of shear also the double connectors configurations (two RADIAL placed side by side) were considered and tested. More than one hundred specimens were tested: 18 in F1T, 80 in F1C and 21 in F2/3. In this paper only the results in F1T and F2/3 test configuration (except for double connectors per each side) were presented and discussed. The load was applied by  $\pm 250$  kN testing machine hinged to a specially designed steel element, fixed to the side A (timber element) of the specimen via threaded rods and steel plates in F1T and directly in contact in F2/3 setup. On side B (steel part) RADIAL was bolted to special design steel supports fixed to the testing machine (Fig. 3 and 4). All the tested connectors were fastened to timber element through 4 fully-threaded screws (partial pattern), VGS and LBSH for RADIAL90 and RADIAL60 (S and D), respectively, while M16 (RADIAL90) or M12 (RADIAL60S and RADIAL 60D) bolt (8.8 or 10.9) is adopted for steel-to-steel connection. The full pattern

configuration of screws (6 screws) was tested in the preliminary experimental campaigns. Timber element on side A was in glulam (GL24h) or CLT (the layups are reported in the following tables). Additional tests were performed on bolts and anchor systems (i.e. U-shape metal plates/forks) to characterize their resistance; more information is available in [3].

#### 3.1 TENSILE CONFIGURATION SETUP

Six configurations summarized in Table 2 (three repetitions for each configuration) were tested according to F1T setup. Screw lengths were chosen to induce the failure in the steel plates/flanges of connectors, avoiding the screw withdrawal (VGS 9x320mm and LBSH 7x200mm for RADIAL90 and RADIAL60D/S, respectively, inserted in GL24h element) while configurations with reduced length (VGS 9x200mm and LBSH 7x100mm for RADIAL90 and RADIAL60D, respectively, inserted in CLT) were tested to study the behaviour of specimens in case of screws withdrawal.

Table 2: Tested configuration F1T setup

ID	Side A	Side A	Side B
R90_GL_F1T	GL24h	4 x VGS 9x320mm	1 x M16 8.8 bolt
R90_CLT_F1T	CLT (20l-40t-20l)	4 x VGS 9x200mm	1 x M16 8.8 bolt
R60D_GL_F1T	GL24h	4 x LBSH 7x200mm	1 x M12 8.8 bolt
R60D_CLT_F1T	CLT (20l-20t-20l)	4 x LBSH 7x100mm	1 x M12 8.8 bolt
R60S_GL_F1T_SY	GL24h	4 x LBSH 7x200mm	1 x M12 8.8 bolt
R60S_GL_F1T_AS	GL24h	4 x LBSH 7x200mm	1 x M12 10.9 bolt

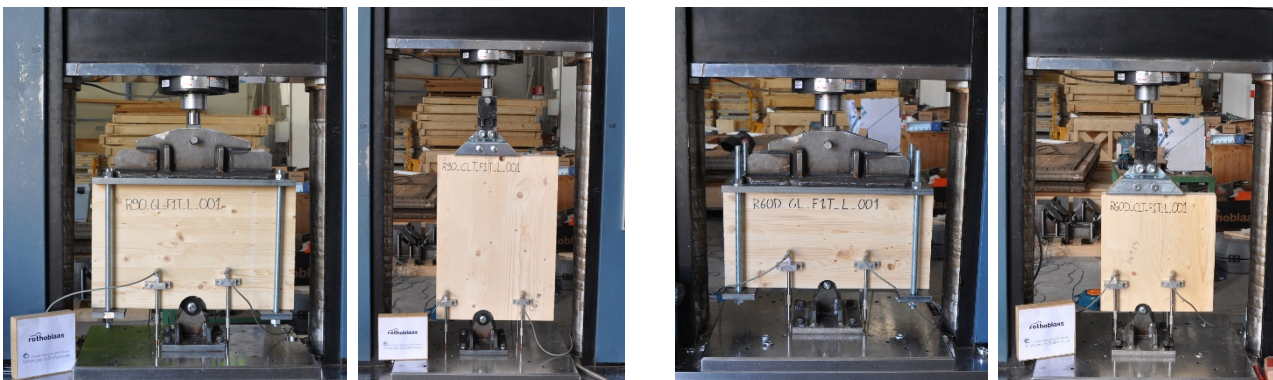

Figure 3. F1T test setups: RADIAL90 (left) and RADIAL60D/S (right)

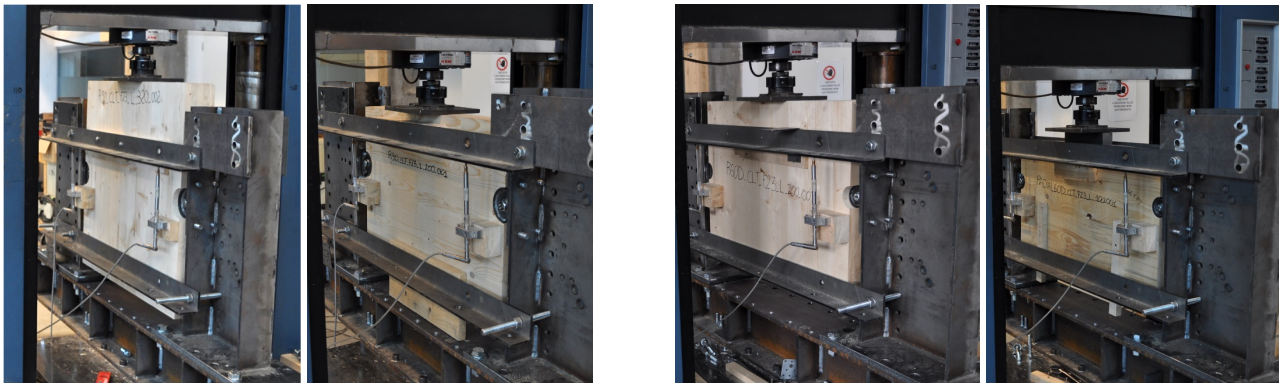

Figure 4. F2/3 test setups: RADIAL90 (left) and RADIAL60D/S (right)

For configurations with shortest screws, RADIAL connectors were installed at the minimum prescribed distance from the edge [3] (Fig. 3). For RADIAL60S (connector with one flange) two configurations were tested: symmetric and asymmetric (R60S\_GL\_FIT\_SY, R60S\_GL\_FIT\_AS), characterized by a bolted anchoring with two or one shear planes. In both cases LBSH screws with maximum available length (200mm) were used to fasten RADIAL60S to GL24h element. Four linear variable displacement transducers (LVDTs) were applied at the tested specimens, two at each wide face of CLT panel or GL24h element on side A, as shown in Fig. 3. The values of displacements used to calculate the mechanical parameters were obtained from the mean value of the four LVDTs.

### 3.2 SHEAR CONFIGURATION SETUP

Five configurations reported in Table 3 (three repetitions for each configuration) were tested according to F2/3 setup.

Table 3: Tested configuration F2/3 setup

ID	Side A		Side B
R90_CLT_F2/3_320	CLT (20t-40l-20t-20l-20t)	4 x VGS 9x320mm	1 x M16 8.8 bolt
R90_CLT_F2/3_200	CLT (20l-40t-20l)	4 x VGS 9x200mm	1 x M16 8.8 bolt
R60D_F2/3_200	CLT (20t-20l-20t-20l-20t)	4 x LBSH 7x200mm	1 x M12 8.8 bolt
R60D_F2/3_100	CLT (20l-20t-20l)	4 x LBSH 7x100mm	1 x M12 8.8 bolt
R60S_F2/3_200	CLT (20l-20t-20l-20t-20l)	4 x LBSH 7x200mm	1 x M12 10.9 bolt

As for FIT setup, screw lengths were chosen to induce failure in steel plate/flanges avoiding withdrawal failure mode (VGS 9x320mm and LBSH 7x200mm for RADIAL90 and RADIAL60D, respectively, inserted in

CLT element with outer transversal laminations) while configurations with reduced length (VGS 9x200mm and LBSH 7x100mm for RADIAL90 and RADIAL60D, respectively, inserted in CLT element with outer longitudinal laminations). For configurations with the shortest screws, RADIAL specimens were installed at the minimum prescribed distance from the edge [3] (Fig. 4), to identify possible brittle failure mode of CLT panel. The most critical configuration of RADIAL60S (R60S\_F2/3\_200 - one shear plane) was tested according to F2/3 setup with M12 10.9 bolt. Four LVDTs were applied to the tested specimens, two at each wide face of CLT panel or GL24h element on side A, as done in FIT setup and shown in Fig. 4.

## 4 – RESULTS

The results of the experimental campaign conducted on RADIAL connectors are presented in terms of mechanical parameters (stiffness  $k$ , maximum load and displacement  $F_m$  and  $u_m$ , calculated according to [5]), failure modes and backbone curves (one curve was selected from each configuration). The parameters in table 4 and 5 are the mean values of the three tested specimens per each configuration and refer to a single connector.

### 4.1 TENSILE CONFIGURATION RESULTS

The mechanical parameters and failure modes are reported in table 4 for FIT configuration. For the longest screws, the failure mode was related to the steel parts of connectors: R90\_FIT\_GL specimens reached  $F_m$  due to steel plate failure (see Fig. 5, left) while specimens R60D\_GL\_FIT and R60S\_GL\_FIT\_SY failed due to embedment of the steel plate at bolt position (Fig. 6, left). R60S\_GL\_FIT\_AS connectors were over-resistant compared to M12 10.9 and the failure always occurred in the bolt (one shear plane, Fig. 6, right). Conversely, the failure of the specimens fastened with the shortest screws occurred due to withdrawal (Fig. 5, right and 6, centre).

The comparison between RADIAL connectors in F1T configuration in terms of backbone curves is reported in Fig. 7 (left).

Table 4: Mechanical parameters and failure modes (F1T)

ID	k [kN/mm]	v <sub>m</sub> [mm]	F <sub>m</sub> [kN]	Failure mode
R90_GL_F1T	31,4	11,6	109,4	Steel plate
R90_CLT_F1T	32,4	6,1	89,5	Screws withdrawal
R60D_GL_F1T	28,7	11,3	71,1	Embedment of the steel plate
R60D_CLT_F1T	28,3	2,4	39,3	Screws withdrawal
R60S_GL_F1T_SY	23,7	9,2	78,5	Embedment of the steel plate
R60S_GL_F1T_AS	35,3	7,4	69,2	Bolt shear failure

## 4.2 SHEAR CONFIGURATION RESULTS

The mechanical parameters and failure modes are reported in table 5 for F2/3 load configuration. In all tested specimens, around RADIAL compressed area, the CLT panel embedment was observed. In the case of longest screws, the failure mode was related to screws

tensile failure (Fig. 8, left and Fig. 9, centre and right); different from F1T configuration no failures in steel plates/flanges occurred. For specimens with shortest screws two failure mode were registered: screws withdrawal and CLT panel shear failure in configuration R60D\_CLT\_F2/3\_100 (Fig. 9, right) and R90\_CLT\_F2/3\_200 (Fig. 8, right), respectively. Additional tests conducted on double connectors configurations confirmed that the results in Table 5 can be extended to double (side by side) connectors configuration multiplying the mechanical parameters (k and F<sub>m</sub>) by two [3].

Table 5: Mechanical parameters and failure modes (F2/3)

ID	k [kN/mm]	v <sub>m</sub> [mm]	F <sub>m</sub> [kN]	Failure mode
R90_CLT_F2/3_320	25,9	11,8	95,6	Screw tensile
R90_CLT_F2/3_200	21,2	4,1	72,2	CLT panel shear failure
R60D_F2/3_200	21,9	9,2	65,0	Screw tensile
R60D_F2/3_100	18,3	3,3	42,3	Screws withdrawal
R60S_F2/3_200	22,6	10,6	70,5	Screw tensile

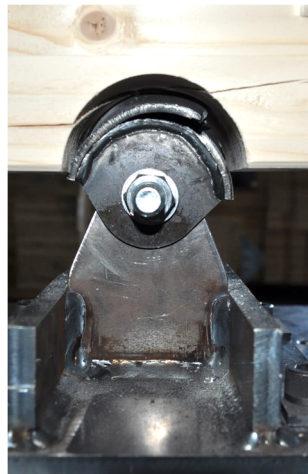

Figure 5. FIT failure modes RADIAL90: steel plate (left) and screws withdrawal failure mode (right)



Figure 6. FIT failure modes RADIAL60D/S: embedment (left), screws withdrawal (centre) and bolt shear failure (right)

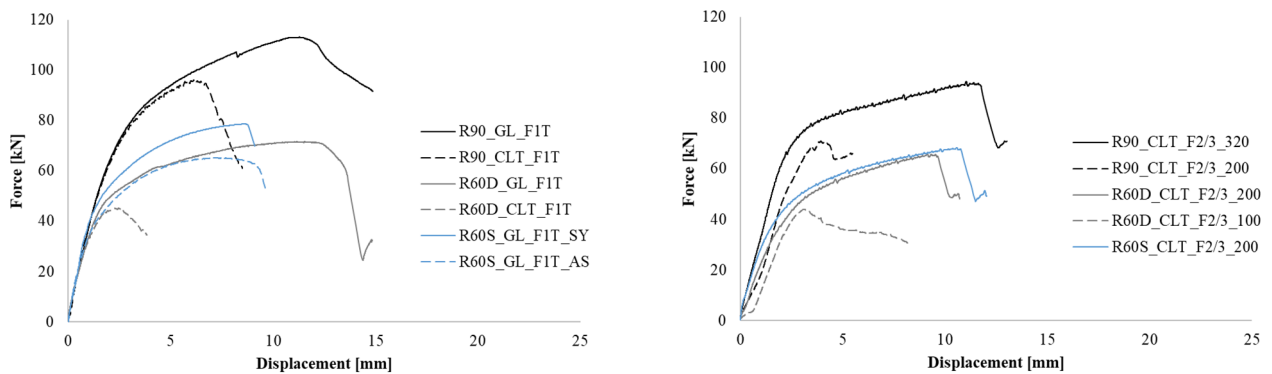

Figure 7. Force-displacement backbones: FIT (left) and F2/3 (right)



Figure 8. F2/3 failure modes RADIAL90: screw tensile (left) and CLT panel shear failure mode (right)



Figure 9. F2/3 failure modes RADIAL60D/S: screw tensile 60S (left), screw tensile 60D (centre) and screws withdrawal 60D (right)

## 5 – ANALYTICAL MODEL

An analytical calculation model, based on the experimental results, was developed and presented in [3]. Following the developed formulations, the load carrying capacity of RADIAL connectors can be predicted. The calculation procedure considers different screw lengths and patterns (full/partial) and use different timber material (e.g. solid timber, glued solid timber and LVL,

[3]) for both load configurations (FIT and F2/3). In Table 6 are reported the angles of each  $i$ -th axis, according to Figure 10.

Table 6: Angles [°] of each  $i$ -th axis

Load direction	$\alpha_{1,1}$	$\alpha_{1,2}$	$\alpha_{1,3}$	$\alpha_{1,4}$	$\alpha_{1,5}$	$\alpha_{1,6}$
	$\alpha_{23,1}$	$\alpha_{23,2}$	$\alpha_{23,3}$	$\alpha_{23,4}$	$\alpha_{23,5}$	$\alpha_{23,6}$
FIT	60	36	12	12	36	60
F2/3	30	54	78	78	54	30

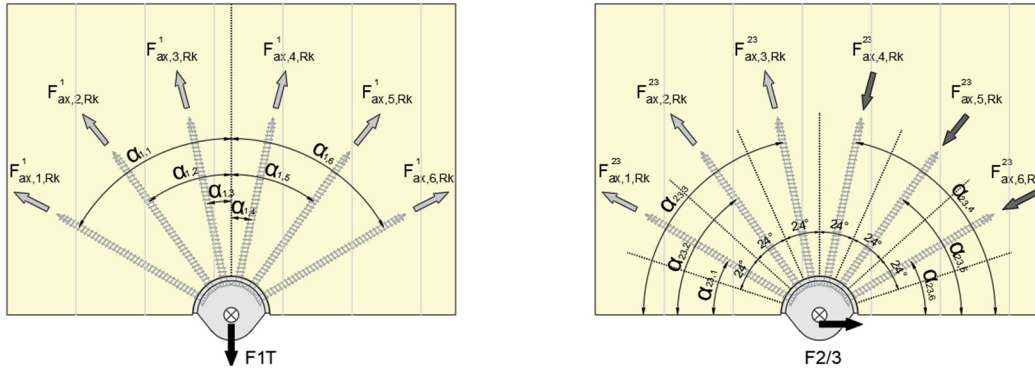

Figure 10. Equilibrium of forces: F1T (left) and F2/3 (right) load configuration

## 5.1 TENSILE ANALYTICAL MODEL

The characteristic load carrying capacity in F1T configuration  $F_{1,t,Rk}$  of RADIAL connectors can be estimated with (1).

$$F_{1,t,Rk} = \min(\sum_{i=1}^{n_s} F_{ax,i,Rk}^1 \cdot \cos(\alpha_{1,i}); n_{sp} \cdot F_{b,Rk}) \quad (1)$$

Where  $F_{ax,i,Rk}^1$  is the minimum between withdrawal and tensile resistance of  $i$ -th screws according to [1],  $\alpha_{1,i}$  is the angle between  $i$ -th axis and F1T load direction, as shown in Fig. 10 (left),  $n_s$  is the number of screws,  $n_{sp}$  and  $F_{b,Rk}$  are the bolt's shear planes and resistance [3,6], respectively. The vertical components can be obtained projecting the resistance of axially loaded screws.

## 5.2 SHEAR ANALYTICAL MODEL

Formulation for partial pattern of fasteners is reported in [3] while the calculation method for full pattern (6 screws) is presented in this paper. The analytical model is based on the equilibrium between tensile loaded screws and their counterpart areas loaded in compression, as shown in Fig. 10 (right). By applying this equilibrium distribution of forces the vertical equilibrium condition is satisfied. The characteristic load carrying capacity in F2/3 configuration  $F_{2/3,Rk}$  of RADIAL connector can be calculated by (2), projecting the horizontal component of each  $i$ -th loaded axis.

$$F_{2/3,Rk} = \min(\sum_{i=1}^6 F_{ax,i,Rk}^{23} \cdot \cos(\alpha_{23,i}); n_{sp} \cdot F_{b,Rk}) \quad (2)$$

Where  $F_{ax,i,Rk}^{23}$  is the minimum between the axially resistance of  $i$ -th screw  $F_{ax,t,i,Rk}^{23}$  and the timber embedment capacity of 24 degrees  $i$ -th segment of circle  $F_{ax,c,i,Rk}^{23}$ , following (3), reported in [3].  $\alpha_{23,i}$  is the angle between  $i$ -th axis and F2/3 load direction, as shown in Fig. 10 (right).

$$F_{ax,c,i,Rk}^{23} = 1,5 \cdot f_{h,\varepsilon,i,k} \cdot B \cdot D \cdot \sin(12^\circ) \quad (3)$$

The expressions to evaluate the embedment strength  $f_{h,\varepsilon,i,k}$  for narrow side of CLT panel (4) and timber/LVL (5) were determined starting from F1C experimental test conducted on RADIAL connectors.

$$f_{h,\varepsilon,i,k} = 0,04 \cdot \rho_k \quad (4)$$

$$f_{h,\varepsilon,i,k} = \frac{0,05 \cdot \rho_k}{2 \cdot \sin^2(\varepsilon,i) + \cos^2(\varepsilon,i)} \quad (5)$$

Where  $\rho_k$  is the characteristic timber density and  $\varepsilon, i$  the angle between  $i$ -th screw and grain direction. As a multi-directional connection system, RADIAL is loaded by a combination of forces (i.e. F1T+F2/3). Consequently, a verification criterion for combined loads was developed and reported in [3].

## 6 – CONCLUSIONS

A new connection system was proposed and discussed in this paper. The connectors consist of a semi-circular shape steel plate with one/two welded flanges, fastened to timber elements with radially arranged fully-threaded screws and fixed by a metric bolt on the other side. Several applications of RADIAL are reported, highlighting the versatility of connectors. RADIAL can be preassembled off-site (screws) and bolted on-site, representing a valuable solution for prefabricated systems. Moreover, fasteners accessibility allows the removing of screws at the end of life of structure, guarantying the option to disassemble connections (removing screws) and the building (removing bolts). An extensive experimental campaign was conducted on the new RADIAL connection system. Three different typologies of connectors were tested: RADIAL90, RADIAL60D and RADIAL60S. Results showed high value of resistance and stiffness for both tested load configuration (F1T and F2/3), demonstrating that RADIAL can be considered also a valuable alternative to traditional connection systems (e.g. hold-down and angular brackets). A comprehensive calculation method was presented and discussed.

## 7 – REFERENCES

- [1] ETA-Denmark, ETA-11/0030. European technical assessment. Screws and threaded rods for use in timber constructions, (2024).
- [2] U. Gegendorfer, Master's Thesis (2021), Untersuchung eines Metallverbinders für gelenkige Fristknoten-Ausbildung auf seine Tragfähigkeit und weiteres Anwendungspotential
- [3] ETA-Denmark, ETA-24/0062. European technical assessment. Rotho Blaas RADIAL connectors, (2024).
- [4] EAD 130186-00-0603. European assessment document. Three-dimensional nailing plates.
- [5] EN26891:1991. Timber structures - Joints made with mechanical fasteners - General principles for the determination of strength and deformation characteristics.
- [6] EN1993-1-8:2005. Design of steel structures. Part 1-8: Desing of joints.