



PAST AND PRESENT OF THE EARTHEN ARCHITECTURES IN CHINA AND ITALY



Edited by
Loredana Luvidi, Fabio Fratini
Silvia Rescic, Jinfeng Zhang



PAST AND PRESENT OF THE EARTHEN ARCHITECTURES IN CHINA AND ITALY

EDITED BY
LOREDANA LUVIDI, FABIO FRATINI
SILVIA RESCIC AND JINFENG ZHANG

This series of volumes comprises research outputs that have been achieved due to the financial contribution of the National Research Council of Italy (CNR) and the the Chinese Academy of Cultural Heritage (CACH) within the context of a Bilateral Agreement of Scientific and Technological Cooperation between these two Institutions.

SCIENTIFIC EDITORIAL BOARD

Chai Xiaoming, Director of the Chinese Academy of Cultural Heritage - CACH
Gilberto Corbellini, Director of the Department of Social and Human Sciences, Cultural Heritage of the National Research Council of Italy – CNR
Maddalena Achenza, ICOMOS-ISCEAH International Scientific Committee of Earthen Architectural Heritage
Loredana Luvidi, CNR Institute of Heritage Science
Fabio Fratini, CNR Institute of Heritage Science
Silvia Rescic, CNR Institute of Heritage Science
Jinfeng Zhang, CACH Chinese Academy of Cultural Heritage

© Cnr Edizioni, 2021
P.le Aldo Moro 7
00185 Roma

ISBN paper version 978 88 8080 470 3
ISBN electronic version 978 88 8080 315 7

Front-page image captions

1. TECLA (Technology and Clay) 3D printed house by WASP and Mario Cucinella Architects, Massa Lombarda, Ravenna, ITALY (2021)
2. Ruins of a vernacular building in Sant'Omero, Abruzzo, ITALY (by Dalila Fortunato and Anna Jaroszewski, 2020)
3. Ruins of Gaochang ancient city, Xinjiang Province, CHINA (by Fabio Fratini and Loredana Luvidi, 2016)
4. Keziengaha beacon tower (Han Dynasty) in Kuche city, Xinjiang province, CHINA (by Center of Conservation of Xinjiang Cultural Heritage, 2020)

TABLE OF CONTENTS

Foreword	
Gilberto Corbellini	5
Chai Xiaoming	6
Introduction	
Loredana Luvidi, Fabio Fratini, Silvia Rescic and Jinfeng Zhang	7
Part 1 - Historical use of earthen materials for architecture	
Earthen Architectures: history, typologies and construction techniques	
Manuela Mattone	11
Conservation of earthen architecture: an overview of international guidelines and resolutions	
Carla Bartolomucci	23
Part 2 - Earthen constructions in Italy and China	
Historical Earthen Architecture in Italy	
Maddalena Achenza	39
Earthen houses in Abruzzo Region (Italy)	
Silvano Agostini, Gianfranco Conti	57
The status of earthen sites in China	
Juwen Guo	69
Part 3 - Conservation of earthen architecture sites in Italy and China	
Earth Materials: characterization and traditional/innovative techniques of conservation	
Fabio Fratini, Loredana Luvidi, Silvia Rescic	85
Earthen construction and seismic action: new perspectives between tradition and innovation	
Luisa Rovero, Giulia Misseri, Ugo Tonietti	101
Conservation of earthen architecture sites in China	
Xiao Zhou, Shuai Tian	115

Part 4 - New perspectives in earthen architecture in Italy and China

Overview of contemporary earthen architecture in Italy Eliana Baglioni	135
Earthen 3D printed constructions towards a new high-efficient way of building Massimo Moretti, Alberto Chiusoli, Lapo Nardoni, Francesco De Fabritiis, Massimo Visonà	147
Research and Practice of Contemporary Earthen Architecture Mu Jun, Zhou Tiegang, Jiang Wei	157

Part 5 - Case Studies

Experimental approaches for the conservation of the Ruguan Yao kiln site in Henan province Jinfeng Zhang	177
Conservation Measures of Ancient City Ruin of Gaochang Jicai Lu	191
Archaeological Site of Lajia Ruins: preliminary study on the screening of reinforcing materials for earthen ruins Min Fan, Yingyi Fu, Yue Chen, Guangzhao Zhang	201
Preservation of the CHANGSHA Tongguan Kiln Site: evaluation of earth properties and reinforcement effect of treatments Ya Xiao, Weiqiang Zhou, Feng Gao, Haibin Gu, Yun Fang, Shaojun Liu	215
Earthen walled villages in the Shanxi Province: Laoniawan (老龙湾) case Laura Genovese, Loredana Luvidi, Roberta Varriale, Fabio Fratini	229
Mud brick architecture in Sardinia. Sulcis as case study Marco Bianchi, Massimo Botto, Paolo Pasci	239

FOREWORD

GILBERTO CORBELLINI

Director, Department of Social and Human Sciences, Cultural Heritage, National Research of Science of Italy - CNR

In 2015 CNR and CACH initiated their collaboration, which introduced, next to the bilateral research project programs, also a book series on China and Italy. This volume is the fourth publication in this series.

The research carried out within this bilateral project and discussed in the contributions of this book deals with the conservation of earthen architecture, widespread in many regions of China and Italy, as well as in other countries of the world. These buildings represent a very perishable cultural heritage due to the low durability of earthen artefacts towards atmospheric agents. Therefore, their existence is in danger because it is difficult to consolidate the earth without causing further damage to the original material.

In China, earthen artefacts comprise wall structures, whole cities and monumental or historic buildings of great value. Their characteristics differ from one territory to another, in relation to the geographical context in which are located and the cultural environment. There is also a diffused vernacular architecture of lesser value that gives character to each territory making it different from any other, but at serious risk of disappearance. Urbanization and the aspiration of people to conditions of better comfort has meant that the countryside has become depopulated with the abandonment of houses that are disappearing without maintenance.

The collaborative work between CACH and CNR researchers aimed at identifying products and methods suitable for the conservation of the earthen material which characterize this architecture. The earthen architecture of Italy is different from the Chinese one and generally present in vernacular heritage. It is a little-known cultural asset but through its study it will be possible to enhance and preserve this architecture which testifies to the wealth of technological-cultural diversity of man's housing adaptations to changing environmental contexts.

The challenges faced by the CACH - CNR joint research project have been and are an important scientific growth ground for ISPC, the CNR Institute dedicated to the study of the conservation and enhancement of cultural heritage in a multi- and interdisciplinary perspective.

Scientific methods and new technologies are now used to improve the understanding of building technologies, conservation aspects and enhancement of this architectural heritage, whose knowledge for a long time was based only on historical and socio-anthropological studies.

CHAI XIAOMING

Director General, Chinese Academy of Cultural Heritage – CACH

Based on the bilateral cooperation framework between CACH and CNR, five selected projects have been initiated and launched in 2016. To show and exchange the achievements of cooperation, both sides plan to jointly edit a series of academic publications. This book, I am glad to see it as the fourth collection of papers growing out of the bilateral cooperation, includes papers on both sides' achievements in researches of history, existing status, conservation and perspectives in earth architectures in China and Italy.

Earthen sites is one of earliest kind of human remains. They show not only our past, but also future. Through the bilateral cooperation, as shown by the papers in the book, refreshing and inspiring light have been shed on complex issues concerning conservation and valorization of earthen sites, the theme of which indeed deserves academic comparison from multi-cultural perspectives to comprehend the evolution of research, conservation and management under different social contexts.

As much as I am pleased to see the book, I look forward to continuing and deepening this kind of bilateral exchanges with more and more fruits growing out of it. Therefore, CACH would like to further our cooperation with CNR and provide all necessary support, to strengthen and advance conservation communication, and cultures behind.

INTRODUCTION

FABIO FRATINI¹, LOREDANA LUVIDI², SILVIA RESCIC³, JINFENG ZHANG⁴

^{1,3} *National Research Council of Italy – CNR – Institute of Heritage Science, Florence, Italy*

² *National Research Council of Italy – CNR – Institute of Heritage Science, Rome, Italy*

⁴ *Chinese Academy of Cultural Heritage – CACH, Beijing, Cina*

The National Research Council of Italy (CNR) and the Chinese Academy of Cultural Heritage (CACH) during the past three years (2016-2018) carried out a Joint Research Project on “Assessment of innovative methods for the conservation of earthen surface”. The project was carried out by the Institute for the Conservation and Valorization of Cultural Heritage (ICVBC) of the CNR that since 1st October 2019 was suppressed to join the new Institute of Heritage Science (ISPC-CNR). The ISPC deals with the study of the conservation and enhancement of cultural heritage with a multidisciplinary approach, which take advantage of scientific methods and new technologies together with historical and social aspects.

The subject of this Joint Research Project was a real challenge and continues to be so. Actually if the decay of building stone materials exposed to the external environment still represents one of the main threats to monuments and architecture all over the world, a fragile architecture such as the earthen one, is in a situation of increased risk considering the climate change problem and the increased rainfall intensity.

Earthen architecture is a type of construction almost unknown to most of the inhabitants of the developed countries and when it is talked about it, is most often in a derogatory way (i.e. “poor mud houses”). Actually, the earthen constructions are spread in many countries and constitute a testimony of skills and habits of peasant civilizations. Earth is one of the oldest materials used in architecture. It was widely used in ancient Egypt and in the civilizations of Mesopotamia and it is mentioned in the Bible (Book of Exodus 5, 6-8). The constructions of Iran, Afghanistan, Yemen, Iraq, Morocco and Mali testify that earthen architecture has evolved and specialized until reaching a remarkable technical perfection (vaulted systems, domes, multi-storey buildings, decorated surfaces). About 30% of the world population lives in earthen buildings.

Earthen buildings are present also in Europe: Germany, United Kingdom, Spain, Portugal, Poland, Hungary, Romania, Baltic countries. In France 15% of the rural population lives in earthen buildings. In Italy, earthen architecture is present in Sicily,

Sardinia, Calabria, Basilicata, Abruzzo, Marche, Tuscany and Piedmont. Similarly, throughout the western part of China, along the Silk Road, earth is the most widespread building material, both in civil and monumental architecture and in fortifications. It is therefore a type of architecture that for good reason constitutes an important cultural heritage, both from a material and immaterial point of view due to the social implications relating to the construction of the buildings which often involves entire communities.

For some decades, however, we have witnessed the gradual abandonment of earthen buildings, because they are considered unhealthy and unsafe, incompatible with the modernity that people are looking for. In addition, there are three other aspects that hinder the use of earth: it is a material whose application requires specific knowledge and skills; it is a fragile architecture that requires scheduled maintenance which, if it fails, leads to decay; modern building standards are still very restrictive and do not favour the use of earth in architecture.

For all these reasons, preserving earthen architecture and ensuring its existence over time is a real challenge. Experiments are needed to identify the means by which to improve its resilience, so as to foster both the preservation of the existing earthen heritage and a more widespread use of earth in new constructions.

This book, in addition to contributing to the dissemination of knowledge of earth architecture in China and Italy, examines the conservation techniques used in the respective countries and the researches that are being carried out to improve these interventions in order to make them more durable and compatible with a material as delicate as earth. The new opportunities that the earth architecture can have in future in the two countries are also illustrated.

Ultimately, this book is an attempt to bridge the gap between the science applied to Cultural Heritage and the real meaning of the so-called "cultural asset".

Cultural heritage is the result of sensitivity, thought, expectations and skill of men and women stratified over the centuries who, with their identities and personalities, have built the reality in which we live today and with the help of science we want to contribute to its preservation.

PART 1

**HISTORICAL USE OF EARTHEN MATERIALS FOR
ARCHITECTURE**



EARTHEN ARCHITECTURES: HISTORY, TYPOLOGIES AND CONSTRUCTION TECHNIQUES

MANUELA MATTONE

Politecnico di Torino, Department of Architecture and Design - Torino - Italy

Keywords: Earthen buildings, construction techniques, typologies

INTRODUCTION

Earthen architectures are ones of the best evidence of the human capacity to create built environments adopting locally available resources. Earth is a versatile material, used since ancient times for the construction of architectural artefacts independently or associated with other materials such as stone, wood, gypsum, lime, vegetable fibers. Although today, earthen constructions are widely perceived as “mud huts”, associated with an image of poverty and social and cultural marginalization, their significance and potential are known and recognised. Many of the oldest buildings in the world have been built with earth; at least one quarter of the world’s population lives in earthen dwellings and in more than 180 sites of the UNESCO World Heritage List incorporated earthen elements (Joffroy et al., 2017, p. 15). As the Lyon declaration¹ states, “earth has been, is, and will be one of the major materials used by humankind to build its habitat and shape its environment” (Joffroy et al., 2017, p. 15).

Earthen buildings, whether monumental buildings or rural dwellings, are traceable all over the world, where the chemical-physical characteristics of the earth and the climatic conditions would allow the adoption of this material for the construction of architectural artefacts. There are many ways to use earth for construction purposes, which are expressions of the cultural identity of the different sites. Hugo Houben and Hubert Guillaud (Houben, Guillaud, 1989, 101) identified twelve ways² which can be

1 Subscribed by all the participants to the XIIth World Conference on Earthen Architecture, Terra 2016 and published in Joffroy T. et al. eds. (2017), *Terra Lyon 2016 Proceedings*, Villefontaine (France).

2 According to Houben and Guillaud earth can be: dug out, cut, filled in, covered, compressed, shaped, stacked, moulded, extruded, poured, formed, daubed (Houben, Guillaud, 1989, p. 15).

adopted for the erection of earthen constructions, among these, seven are the most widespread. They are: *pisé* (also known as rammed earth, it is a constructive procedure that consists in "beating" - *piser* - the specially prepared earth inside a mobile wooden formwork); *bauge* (earth-straw dough adopted to shape irregular elements which, once overlapped, are regularized with the aid of a sharp blade); *torchis* (earth application on a timber support); *adobe* (construction technique that uses raw bricks, made by hand compacting, in wooden forms, a mixture of earth which are often added vegetable fibres); *earth-straw* (earth, which must be characterised by high cohesion, is dissolved in water and poured on the straw so as to cover it all); *forming* (earth is shaped by hand as if it were pottery) and *compressed block* (earthen blocks are produced using hand tools or mechanical presses so as to improve mechanical performances, thanks to the reduction of cavities and water content) (Fig. 1).



Fig. 1 Adobe rural architecture in Morocco (by M. Mattone, 2015)

Many treatises and manuals widely address the earth constructions topic. Vitruvio in the *De Architectura* indicates how to select the earth to be used for the production of bricks³ and the best seasons for the construction of the buildings in order to guarantee their better durability. Plinio illustrates how to make the walls in *pisé*, underlining that "these last many summers resisting rains, winds, fires with more solidity

3 Vitruvio Pollione M. (15BC), *De Architectura*, Books X, Roma, (It. transl. Migotto L. Porde- none. Edizioni Studio Tesi, 1990), 2nd book, pp. 73-75.

than any cement wall"⁴. Rammed earth technique generates increasing interest at the end of the eighteenth century, when new construction systems are extensively experimented. In 1791 François Cointeraux⁵ published his studies on rammed earth. It was translated into English, German and Italian, ensuring the spread of this construction technique across Europe. The studies, concerning earthen building techniques, are resumed again in 1802 by Jean-Baptiste Rondelet⁶ and, later (Figg. 2-3), by Daniele Donghi⁷ (1920) and by Gustav Adolf Breyman⁸ (1926).

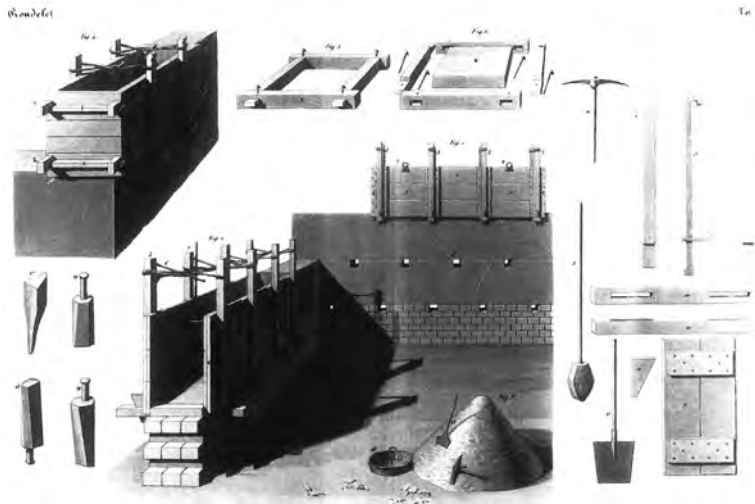

Fig. 2 Tools and methods for the construction of earthen walls in pisé (Rondelet J-B. (1860). *Traité théorique et pratique de l'art de bâtir*. Paris. Firmin-Didot, tav. IV)

- 4 G. Plinius Secundus, *De Naturalis historia*, 77, (It. Transl. M.L. Domenichi, G. Antonelli ed., Venezia 1844), XXXV, XLIII.14.
- 5 Architect and professor of rural architecture, François Cointeraux (1740-1830), born in Lyon, publishes four small volumes illustrating the construction system he perfected himself, thanks to the experimentation of a mechanical method of great simplicity, useful for the realization of earthen walls. In *Ecole d'architecture rurale, ou Leçons par lesquelles on apprendra soi-même à bâtir solidement les maisons de plusieurs étages avec la terre seule, ou autres matériaux les plus communs et du plus vil prix*. Paris, 1791, Cointeraux explains methods and rules for the production of earthen wall, for the choice of the optimal earth and for the production and application of plasters and decorations.
- 6 Rondelet J-B. (1860). *Traité théorique et pratique de l'art de bâtir*. Paris. Firmin-Didot.
- 7 Donghi D. (1920). *Materiali, elementi costruttivi. e finimenti esterni delle fabbriche*. Torino. UTET.
- 8 Breyman G. A. (1849). *Allgemeine bau Constructions Lehre*. Stuttgart. Hoffmann (It. Transl., *Trattato generale di Costruzioni civili con cenni speciali intorno alle costruzioni grandiose: guida all'insegnamento e allo studio*. Milano. Vallardi. 1926).



Fig. 3 Constructive features of a rammed earth building. (Rondelet J-B. (1860).
Traité théorique et pratique de l'art de bâtir. Paris. Firmin-Didot, tav. V)

EARTHEN CONSTRUCTIONS IN THE WORLD: monumental and vernacular architectures

The first use of earth as a building material probably comes from the need to make sheltered places, such as caves, more comfortable (Guerrero, 2007, Jaquin, Augarde, 2012). The progressive transition from a nomadic life model to a sedentary one has led to the birth of the first permanent settlements and the development of solid and durable building materials, too. "The first earthen building technique to develop is likely to have been wattle and daub: construction of a façade or roof using timber or grasses, which is covered in earth. Later a rammed earth type of technique may have been developed" (Jaquin, Augarde, 2012, p. 13), compacting earth by hand and afterwards using wooden formworks. Earthen constructions initially arose along the banks of rivers such as the Tigris, Euphrates, Nile, Indus and Huanghe, where sandy and clayey earth was normally mixed with straw resulting from the cultivation of cereals and adopted as building material. The subsequent development of single constructive elements (such as blocks) would allow, once dried, to transport them, giving the opportunity to build earthen constructions even at a certain distance from the rivers' banks (Jaquin, Augarde, 2012, pp. 13-14). Earth buildings can be found in Africa, Asia, Europe and America. Vernacular architectures, as well as monumental buildings are made using raw earth technology.

In Africa, the earliest woven reed and branch earth-covered sites date back to 5000 BC in the Nile Delta (e.g. Mermide and Fayun); the production of hand-made adobe bricks began starting from 2900 BC approximately and they were used in the construction of monumental buildings such as the large independent adobe structures at Shunetel-Zebib and Nekhen and the pyramids discovered at Tamis. Also many of the buildings built by the Pharaoh Ramsese II (1279-1213 BC), as well as the dwellings of artisans, nobles and temples were in adobe. Generally, the most modest dwellings consisted of one or more rooms whose walls were made of earth and covered with lime plasters. The rich mansions of the nobles, equipped with several rooms and spaces intended for servants, were more spacious and entirely built with earth (see, for example, the settlement of Deir el Medina). As far as North Africa is concerned, the influence exerted by different civilizations that have succeeded over time has contributed to the dissemination of both the techniques of adobe and pisé. Starting from the eleventh century, the spread of Islamic culture determines a significant change in the characteristics of urban settlements and the construction of a new type of religious buildings such as mosques. In Morocco, in the valleys of the Drâa and Dadès rivers there are hundreds of rammed earth settlements like the ksar of Aït Ben Haddan and the kasbah of Tourit in Ouarazazate (Figg. 4-6). The urban walls of Marrakech and Fes are also made of rammed earth. As for the mosques, the most significant examples can be found in Mali (such as the Great Mosque of Djenné and the Djinguereber Mosque in Timbuktu) and in the Niger (Great Mosque of Agadez). They are decorated with bundles of palm stalks that, protruding from the wall, are used as scaffold for annual maintenance interventions of the earth surfaces.



Fig. 4 Earthen settlement in Morocco (by M. Mattone, 2015)



Fig. 5 The Kasbah of Tourirt in Ouarazazate (Morocco) (by M. Mattone, 2015)



Fig. 6 Earthen building in Ouarazazate (Morocco) (by M. Mattone, 2015)

In the Near Middle East, the earth finds application in the construction of monumental buildings such as the temple cities of the Uruk period (3200-2800 BC) and the sanctuaries, erected in the third millennium BC (e.g. the temple of Euki a Eridu), made of bricks assembled without mortar. Interesting buildings can be found also in Iran. Historic adobe buildings stand in the cities of Yazd and Isfahan; rammed earthen walls surround the city of Tous; adobe structures characterised also the citadel of Bam, the largest adobe settlement in the world, unfortunately collapsed because of an earthquake in 2003. In Yemen, from the XVIII century many buildings were erected, such as the adobe minaret of the Al-Muldher Mosque which, being 53 m high, "is probably the tallest earthen structure in the world"

In the Far East, earth is widely adopted in the construction of walls, as well as residential buildings. The first defensive rammed earth walls were erected by the Qin dynasty (221-206 BC) in the plains along the northern borders in western China⁹. "However, it is in the Great Wall where the use of rammed earth is most recorded" (Jaquin, Augarde, Gerrard, 2008, p. 380). These walls were restored and extended by the Han dynasty (206 BC – 202 AD) and the Jin dynasty (265-420 AD), but few original sections remain (Jaquin, Augarde, Gerrard, 2008).

As far as residential buildings are concerned, the *Tu lou* (which means earthen structures) are particularly interesting examples: they are large round or square four storeys rammed earth constructions erected for defence purposes around a central open courtyard (Jaquin, Augarde, Gerrard, 2008). The presence of only one entrance and no windows at the ground floor make them easy to defend. Recently inscribed in the World Heritage List, they are "exceptional examples of a building tradition and function exemplifying a particular type of communal living and defensive organisation and, in terms of their harmonious relationship with their environment, an outstanding examples of human settlement"¹⁰.

In Europe, the construction techniques used are multiple (Guillaud, 2008; Correia, Dipasquale, Mecca, 2011). In northern Europe, mixed earth and timber structures with wattle and daub or half-timber techniques are adopted. *Cob*¹¹ structures dating back to the XVth century, have been found in the UK and this constructive technique has been used up to the XIXth century, even if the adoption of earth as a building material declined from the XVIth century because of the increasing use of fired bricks. In the South, adobe and rammed earth techniques are more common. The first buildings date back to about 5300 years ago and are located in Sesklo in Greece. These are single-storey residential buildings in torchis and dried bricks resting on a stone base. Rammed earth, which may have been brought to Europe by

9 Jaquin, Augarde, 2012, p. 16, Jaquin, Augarde, Gerrard, 2008, p. 380.

10 <https://whc.unesco.org/en/list/1113> (visited on the 12th October 2018).

11 English term used for earth walls built up without formwork.

Phoenicians (Houben, Guillaud, 1989), is widely adopted in Spain¹² (Mileto, Vegas, 2014, García-Soriano, Villacampa Crespo, Gómez-Patrocínio, 2018), France (Guillaud, 2008), Italy (Bertagnin, 1999; Sori, Forlani, 2000; Mattone, 2010; AA. VV., 2011), Portugal (Fernandes, Correia, 2005). City walls (e.g. the ones of Cordoba, Seville and Granada), monumental buildings (e.g. the Alhambra Palace in Granada) (Fig. 7), both urban (e.g. the historic city centre of Novi Ligure in northern Italy and of Lyon in France) and vernacular architectures (such as the rural buildings of Piemonte, Sardegna, Marche, Abruzzo, Calabria regions in Italy and of Rhône-Alpes and Auvergne regions in France) can be found in different countries (Fig. 8).



Fig. 7 The wall of the Alhambra Palace in Granada (by M. Mattone, 2017)

12 In Spain, the adoption of earth as building material is already stated by Plinius who, in 77 AD, writes: "Spain still sees the watchtowers of Hannibal [who invaded Iberia in 218 BC] and turrets of earth placed on mountain ridges" (Plinius Secundus G. (77). *De Naturalis historia*, (it. Transl. M.L. Domenichi, G. Antonelli ed., Venezia 1844), XXXV, XLIII.14). Rammed earth (called Tapia) would be widely used starting from the VIII century by Muslims for the construction of military and civil architecture.



Fig. 8 Earthen vernacular architecture in Priocca (Cuneo, Italy) (by M. Mattone, 2016)

In America, earthen constructions are both in the North and in the South. In North America (Mexico and Southern United States), earth was used by native populations. The Aztecs built their monumental architectures in stones, while vernacular buildings were built in adobe. The latter were also used by Europeans coming to North America for the construction of missions and frontier forts such as Tomacacori, Guevavi and Calabazas Jesuit missions in Arizona (1691). Later, in the middle of the XIX century, the US army also adopted the adobe technique to build Fort Union and Fort Selden. As for the rammed earth technique, it was brought to the American country by German immigrants. Rammed earth constructions can be found in Washington (Hilltop House), at Mount Vernon, in Trenton (New Jersey), in Canada (St Thomas Church in Shanty Bay and residential buildings in Greenville).

In South America archaeological evidence of earthen buildings can be found in the coastal regions of Peru. First proof of the use of raw bricks is related to Moche culture, which developed in northern Peru between the IInd century and the IXth century. In the city of Cerro Blanco, two pyramids, dedicated to the sun and the moon, were built. They are adobe core pyramids almost 50 m tall. After the decline of the Moche culture the largest civilisation to develop was the Chimú. Chan Chan was the capital of the Chimú culture. In 1875 the archaeologist Ephraim George Squier described

Chan Chan as "the most extensive and populous of all the cities of ancient Peru". It consists of "long lines of massive walls, gigantic chambered pyramids, or *huacas*, remains of palaces, dwellings, aqueducts, reservoirs, granaries, prisons, furnaces, foundries, and tombs, extending for many miles in every direction" (Squier, 1877, p. 113). Beside the adobe constructions, rammed earth buildings can be found in south America. In fact, during the XVIth century, the European settlers brought new building techniques. "In 1549 a Jesuit missionary sent a request to Europe to send 'artisans able to handle soil, and carpenters, for the construction of the Colégio da Companhia in São Paulo" (Jaquin, Augarde, 2012, p. 24). Monumental and vernacular buildings can be found also in other countries and, as it is stated by Houben and Guillaud, up to now, in Latin American countries, both earthen brick and rammed earth are still the main building materials (Houben, Guillaud, 1989).

EARTHEN CONSTRUCTIONS BETWEEN PAST AND FUTURE

Earth is one of the most used materials in the construction industry: the conservation of the earthen heritage guarantees the safeguard of a technological culture that includes landscape and historical values. The transmission of knowledge connected to these constructions represents, together with the protection of material testimonies, the way through which foster the preservation of the earth culture and, therefore, the transmission of its civilization values.

The "culture of the earth", expression of the peasant roots of populations, is found in many settlements that are nowadays often strongly compromised. The progressive lack of their necessary maintenance, due to the widespread desire to replace raw earth with materials more "modern", "durable" and with "better" performances, has significantly contributed to their rapid degradation. They have often been abandoned or subjected to inappropriate interventions such as: demolition, substitution or reintegration adopting materials with characteristics different from those of the earth and responsible for the onset of degradation phenomena and their consequent rapid destruction (Haman, 2008, Mattone, 2010).

Recently, however, they have become the subject of renewed interest. The results of researches carried out during the last decades state the advantages of earth as a building material. Available in nature at an extremely low cost, earth requires a reduced energy cost for its processing and offers the opportunity to realise building with a remarkable living comfort thanks to its characteristics of breathability and thermal insulation (AA. VV. 2011; Fontaine, Anger, 2009).

Preserving and passing on knowledge about the material, construction standards and construction techniques can constitute important possible references for the creation of a new sustainable architecture. Therefore, the preservation of such material evidence should be promoted not only for the protection of the culture of the raw earth and for the transmission of the values of civilization that characterize it, but also

for a greater diffusion of sustainable architectures, with none or very low environmental impact.

BIBLIOGRAPHICAL REFERENCES

- AA.VV. (2011). *Earth/Lands. Earthen Architecture in Southern Italy*. Pisa. ETS. ISBN 978-884672146-4.
- Bertagnin M. (1999). *Architetture di terra in Italia. Tipologie, tecnologie e culture costruttive*. Monfalcone. Edicom. ISBN 88-86729-14-6.
- Breyman G.A. (1849). *Allgemeine bau Constructions Lehre*. Stuttgart. Hoffmann (it. Transl., *Trattato generale di Costruzioni civili con cenni speciali intorno alle costruzioni grandiose: guida all'insegnamento e allo studio*. Milano. Vallardi. 1926).
- Cointeraux F. (1791). *Ecole d'architecture rurale, ou Leçons par lesquelles on apprendra soi-même à bâtir solidement les maisons de plusieurs étages avec la terre seule, ou autres matériaux les plus communs et du plus vil prix*. Paris.
- Correia M. Dipasquale L., Mecca S. (eds.). (2011). *Terra Europae. Earthen Architecture in European Union*. Pisa. ETS. ISBN 9788846729576.
- Donghi D. (1920). *Materiali, elementi costruttivi. e finimenti esterni delle fabbriche*. Torino. UTET.
- Fernandes M., Correia M. (2005). *Arquitectura de terra em Portugal*. Lisboa. Argumentum. ISBN 972-8479-36-0.
- Fontaine L. Anger R. (2009). *Bâtir en terre. Du grain de sable à l'architecture*. Luçon. Belin. ISBN 978-2-7011-5204-2.
- Galdieri E. (1982). *Le meraviglie dell'architettura in terra cruda*. Roma-Bari. Laterza. ISBN 978-8842020653.
- Galdieri E. (1986). *Arquitectura de tierra - histórica y moderna - en Italia*. "Informes de la Construcción", vol. 37, n. 377, pp. 51-53.
- Guerrero Baca L. F. (ed) (2007). *Patrimonio construido con tierra*. Ciudad de México. UAM Xochimilco. ISBN 978-970-31-0827-5.
- Guillaud H. (2008). *A global challenge: preserving earthen architecture*. "World Heritage", n. 48, pp. 4-17.
- Guillaud H. (ed.). (2008). *Terra Incognita. Découvrir une Europe des architectures de terre*. Lisboa. Argumentum. ISBN 9782960052732.
- Haman M. (2008). *Earthen architecture against impoverishment*. "World Heritage", n. 48, pp. 42-49.
- Houben H., Guillaud H. (1989). *Traité de construction en terre*. Marseille. Parenthèses. ISBN 2-86364-041-0.
- Joffroy T., Guillaud H., Sadozai C. (2017). *Terra Lyon 2016*. Villefontaine. CRA-terre. ISBN 979-10-96446-11-7. (Proceedings of the XIIth World Congress on Earthen Architecture, Lyon, 11-14 July 2016).
- Jaquin P., Augarde C. (2012). *Earth Building. History, science and conservation*. Bracknell, IHS BRE Press. ISBN 978-1-84806-192-7.

- Jaquin P., Augarde C., Gerrard C. M. (2008). *Chronological Description of the Spatial Development of Rammed Earth Techniques*. "International Journal of Architectural Heritage", 2:4, pp. 377-400.
- Mecca S. et alii (eds) (2011). *Earth/Lands. Earthen Architecture of Southern Italy*. Pisa. Edizioni ETS. ISBN 978-884672146-4.
- Mattone R. (2010). *Il paesaggio delle case in terra cruda*. Savigliano. L'Artistica editrice. ISBN 978-88-7320-232-5.
- Mileto C., Vegas F. (eds.). *La restauración de la tapia en la península ibérica. Criterios, técnicas, resultados y perspectivas*. Lisboa. Argumentum. ISBN 978-972-8479-83-1.
- Plinius Secundus G. (77). *De Naturalis historia*, (It. Transl. Domenichi M.L. (1844). Venezia. G. Antonelli ed.), XXXV, XLIII.14.
- Rondelet J-B. (1860). *Traité théorique et pratique de l'art de bâtir*. Paris. Firmin-Didot.
- Sori E., Forlani A. (2000). *Case di terra e paglia delle Marche*. Ascoli Piceno. D'Auria editrice.
- Squier E.G. (1877). *Peru. Incidents of travel and explorations in the Land of the Incas*. London.
- Vitruvio Pollione M. (15BC), *De Architectura*, Books X, Roma, (It. Transl. Migotto L. Pordenone. Edizioni Studio Tesi, 1990), 2nd book.

CONSERVATION OF EARTHEN ARCHITECTURE: AN OVERVIEW OF INTERNATIONAL GUIDELINES AND RESOLUTIONS

CARLA BARTOLOMUCCI

University of L'Aquila - Department of Civil, Construction Architectural and Environmental Engineering, L'Aquila, Italy

Keywords: Earthen architecture, conservation, authenticity, integrity, compatibility

Attention first turned to the conservation of the world's earthen heritage towards the end of the 1960s, following a few archaeological campaigns in the Middle East (Iraq). Starting in 1972, the topic became the subject of special academic conferences spearheaded by Piero Gazzola, the first president of ICOMOS.

Today, a fresh reading of the *Proceedings* and *Resolutions* resulting from the international meetings over a fifty-year period allows us to 'take stock' of the current situation and, in particular, compare the theoretical premises with the actual work that has been done. Through these documents and the rich body of published research that they inspired, a considerable corpus of in-depth (increasingly geographically broad) information about earthen heritage emerges to which the development of theoretical reflections on the topic and coherent conservation practices do not always correspond.

Since historical earthen architecture constitutes a considerable part of the Cultural Heritage identified by UNESCO (around 15% of the World Heritage List)¹, conservation of this evidence cannot neglect the essential aspects for which it is recognised as "Heritage of Humanity"². While recognising that the material out of which these works are made poses particularly complex conservation problems due to its perishable nature, this characteristic cannot justify total reconstruction or replacement

1 *Earthen architecture in today's world*, UNESCO 2012, 260.

2 "To bear a unique or at least exceptional testimony to a cultural tradition or to a civilization which is living or which has disappeared; to be an outstanding example of a traditional human settlement, land-use ... which is representative of a culture or human interaction with the environment" (UNESCO *Criteria*, III-V).

activity that would jeopardise its authenticity and erase its history. Such practices are extraneous to the conservation of historical-cultural heritage.

In the following, we shall trace the conceptual path marked out by the conferences over the years, with the aim of determining its topicality and identifying the criticalities entailed by the various developments, more or less in line with the original conservation premises.

THE INTERNATIONAL CONFERENCES FROM 1972 TO TODAY

It is immediately clear that a limited number of reports, devoted to historical knowledge of earthen architecture and study of conservation technologies, were presented at the first conferences (between 1972 and 1987). Comparison of research and experience was carried out in a really interdisciplinary context (Piaget 1967). Dedicated questionnaires were distributed to identify and compare the issues encountered in the conservation of these structures worldwide, "to encourage standardization of testing procedures" (Torraca 1980, p. VI). Particular critical issues were then highlighted to be addressed in subsequent research and it was stipulated that this research would be gathered by ICOMOS-ICCROM and circulated worldwide (*Resolutions Yazd 1976*, pp. 265-268).

Starting in 1990, the conference topics began to increase considerably and, as a consequence, the meetings were divided into distinct sections. This led to the separation of the historical-conservation approach from the technical-scientific one, having been addressed together until then. New research areas were added to the original themes, including anti-earthquake structural analyses, attention to urban and socio-economic context and restoration of existing buildings. In particular, this last topic highlights new interests (environmental sustainability, socio-economic aspects) and different aims (reuse, modernisation of building traditions) that led to maintenance practices that sometimes conflicted with the initial conservation premises.

At the first conferences, although a distinction was drawn between 'archaeological sites' and 'buildings in use', attention was primarily focused on the former due to their greater cultural interest. Subsequently (parallel to extension of the concept of 'monument' from the single building to include the urban environment and 'minor' architecture)³, case studies of existing buildings steadily increased, with the aim of keeping them in use or restoring them to functionality. From then on, the primary objective was no longer the conservation (understood as authentic transmission of material evidence of historical-cultural importance) since other factors (such as sustainability, economic feasibility, social issues and future development) being taken on board that led to a notable revival of earthen building techniques. These techniques were used both for the restoration of existing structures and the construction of new ones.

3 See the *Venice Charter* (1964) for the Restoration/Conservation of monuments and sites.

Taking a close look at the acts of the various conferences, we find that the aim of the first meetings was to “establish an international methodology for the study and conservation of earthen architecture”.

In particular, as early as the 1972 Conference (Yazd, Iran), it was not only recommended to protect the monuments from the damage of time but also to shield them from inappropriate interventions. The position taken was clearly in line with restoration guidelines, understood in a conservative sense and entailing attention to material and figurative authenticity. Indeed, we read that, “from the perspective of respect for the original structure, conservative surface treatment is preferable to covering the surface with plaster, which would need to be periodically renewed. Covering with cement plaster or with bricks completely conceals the original remains and belongs to the field of — more or less arbitrary — reconstruction and interpretation rather than that of the authentic conservation of historical monuments” (Gullini, Torraca 1972).

At the 1976 conference (Yazd, Iran), we find special attention paid to archaeological sites and it was recommended “that no archaeological excavation of sites likely to contain the remains of structures in mud brick should be undertaken unless a provisional conservation policy has been established”, since once unearthed, these structures deteriorate extremely quickly. In the case of structures in ruined state, their stability and integrity needed to be guaranteed; in that of buildings in use, periodical maintenance was of fundamental concern. It was, however, specified that “restoration should respect the spirit of the Venice Charter”; the reference to the principles of restoration, as opposed to falsifying reconstruction, is clear. The influence of this document also appears in the specific call for “towns and quarters (...) to be rehabilitated and adapted to modern living standards without losing their character, keeping their typical architectural features”.

At the subsequent meeting in 1977 (Santa Fé, New Mexico, USA), a need was expressed for development of historical research on earthen architecture, along with study of the material itself. Guidelines were also provided that were to “be considered when planning any adobe preservation project” laid out (as in the *Carta Italiana del Restauro* of 1972) in a list specifying what was ‘recommended/not recommended’. Consistent with restoration principles, the following were recommended: “contemporary intervention that is distinguishable”, “use of new materials which are compatible”, “preservation of alterations and additions that may have acquired historical significance”, “adequate documentation prior to initiation of any preservation action”.

In 1980 (*Ankara, Turkey*), the definition of ‘earthen architecture’ appeared for the first time; that required attention not only to materials (*mud-brick* or *adobe*) but also “to all architecture, historic or contemporary, that is constructed of earth materials”. In parallel, a distinction also seems to have been made between ‘monuments’ and ‘vernacular architecture’, which is to say minor structures to be preserved as evidence of a historical culture at risk of disappearance. The latter, while fully included within the UNESCO definition (see *Criteria III*), nevertheless seemed extraneous to the restoration sphere and became the object of building salvage. In spite of the initial

definition of *earthen architecture*, attention seems to have been focused more on materials and construction techniques than on the architecture itself. The history of the buildings seems to have been moved to the background⁴. As a consequence, the elements testifying to the authenticity of these works were neglected and often subjected to total reconstruction (Bartolomucci 2005).

In 1983 (Lima, Peru), the theme of training took on special importance, with the aim of reclaiming and passing down traditional construction techniques. The theme of conservation was flanked by sociological and ecological approaches, which had until then remained in the background. In particular with regard to the practical results of this change, it is here important to emphasise a few orientations that marked a reversal with respect to the past: the aim of the conference was no longer to study historical earthen architecture in view of its conservation, but rather to “circulate knowledge of adobe construction and raise awareness of the importance of preserving and reassessing both old earthen monuments and the techniques used for building with this material”.

The principle of distinguishability, included a few years earlier among the guidelines for restoration, seems to have now disappeared: use of traditional techniques is prescribed not only for maintenance but also for “completing and repairing old buildings, thus ensuring the survival of the skills through the use of like techniques and materials”. Therefore, the transmission of a traditional construction technique led to justification of such activities as completion and reconstruction of historical buildings that remained unfinished or were in ruin⁵. The historical meaning and authenticity of the buildings was undervalued or entirely ignored.

In 1987 (Rome, Italy), the importance of training was also stressed by the participation in the conference of CRATerre and the Ecole d’Architecture de Grenoble. The conference’s declared aim was “to expand current knowledge of methods and techniques appropriate for earthen architecture conservation”, but in this case as well, we find a marked inclination towards training focused on modernising traditional building techniques. In the opening speech, it was indeed affirmed that “this knowledge of historical heritage and the *know-how* of the people of the past is an invaluable treasure that can be reproduced today with the contribution of modern technology and science” (Doat, Verdillon 1988, p.V). In spite of these premises, which are quite distant from those of conservative restoration, the results were presented of important experiments that used ethyl silicate (Chiari 1988, pp. 25-32) and additives of organic origin to strengthen adobe (Vargas Neumann, Mehta 1988, pp. 103-107), with the aim of preserving the authentic material.

4 “The use of traditional methods and materials should be encouraged, because they are often highly appropriate for the preservation. Even more important is the contribution these methods and materials make to the organic quality of earthen architecture, particularly as it relates to its inhabitants” (*Recommendations* in Ankara 1980, 281–84).

5 See the restoration of the Bahla Fort in Oman, restored between 1993 and 1999.

The 1990 Conference (Las Cruces, USA) stands out for a high number of talks, divided into themed sessions (history and tradition, conservation and restoration, site preservation, material consolidation, current construction, humidity problems, chemical and micro-structure of clay, future directions). All of the initial interdisciplinarity seems to have disappeared, now replaced by a multi-disciplinarity that prevents true synergy. The theoretical and methodological orientations were fragmentary and, unlike previous conferences, there was, for the first time, no summary with final recommendations.

From then on, the number of reports steadily rose. In 1993 (Silves, Portugal), the various specialist topics remained divided, with a few changes from the previous meeting (history and tradition, conservation methodologies and techniques, conservation case studies, earthquake resistance, industrial prospects, future directions). In the final recommendations, emphasis was placed on the conviction that “conservation of earthen heritage should not be limited to building preservation but should also consider construction traditions” and that, “from this point of view, the priority is not only training activity but also modernisation of earthen technologies and building practices”. The historiographic approach remained wanting: attention was focused on study of “building cultures” but chronological references seem to have been almost entirely absent in the illustrated cases. There seems to have been confusion — already seen in the previous meetings — between restoration (understood as conservation of cultural evidence) and recovery (aimed at building reuse), as well as between interventions on historical buildings and new construction.

The emergence of diversified interests, often cited (“conservation of architectural heritage will need to be framed in a broader context of development, environment and quality of life. Technical issues will not be able to be disassociated from social, economic, political and cultural conditions”), seems to have contributed to the increasing distance between practice and methodological reflection on the one hand and the restoration sphere on the other. The need was highlighted to define “guidelines for correct conservation practices”, including in reference to the ethical principles of the restoration charters. Reference to the need to “conduct research with more scientific methods” revealed a rather chaotic overall tendency.

At the Conference in 2000 (Torquay, UK), the various topics were again divided: archaeological sites and monuments, materials, conservation and maintenance, continuation of tradition, political, economic and legal context. In the *Resolutions*, the ‘holistic’ approach to conservation was cited and the idea that ‘the conservation of earthen architecture must be aimed not only at preserving buildings but also building traditions’ was again repeated. The term ‘*geo-architecture*’ was introduced, but in this case as well, the reference to ecology seems to distance historical and conservation interests, in favour of sustainability and reuse.

The opening talks tried to take stock of the situation from the methodological perspective: one cited the state of the art of knowledge from the technical-scientific point of view and compared the topics of the previous international conferences (Chiari

2000, pp. 107-114); the other presented a summary of the previous recommendations synthesised by keywords (Taylor 2000, pp. 189-194). There was a call to focus more attention on assessment of the results and outcomes of previous work and, therefore, on documentation of the state of preservation and current interventions.

At the 2003 (Yazd, Iran) meeting, the reports were no longer organised by topic and there were no final recommendations. There was still clear (never resolved) contamination between history and tradition, the ecological approach for sustainable development and the dialectic/opposition between progress and continuity with the past. Among the contributions, there was a critical review of the literature on the topic (Guillaud-Avrani 2003, pp. 201-220) and reflection on the relationship between conservation and development, in which the concepts of integrated conservation, authenticity and integrity (functional, structural, visual) made a return (Jokilehto 2003, pp. 11-18).

At the 2008 Conference (Bamako, Mali), the reports were once again divided by theme and, in particular, distinction was again made between conservation of 'living sites' and of 'archaeological sites'. The 'intangible aspects' (in reference to oral traditions of know-how), which need to be preserved along with the tangible ones, made their appearance⁶. Alongside the multiplicity of topics (problems caused by natural and seismic activity, results of scientific research on conservation, training, challenges and opportunities for conservation and development) we find a proposal for '*Standards and Guidelines for new and existing structures*'. The recommendations and general conclusions emphasise that "the study of earthen architecture has become (or is fast becoming) a discipline in its own right with an explicit terminology, a defined body of knowledge, and its own pedagogy". It is again stressed that "conservation initiatives must involve the local community; this is essential if efforts are to be sustainable and the heritage is to be valued and cared for the long run" (Teutonico 2008, p. 389). It is further affirmed that "conservation and development are not antithetical, but are part of a *continuum*".

This affirmation, although sound, seems to increase the confusion between authentic conservation of historical-architectural heritage and possibilities for current/future development of earthen architecture. As we shall see below, there no longer seems to be a theoretical and practical distinction between two profoundly different themes. If the hoped-for continuity is detached from solid historical awareness, there is a risk of falsifying earthen heritage.

The 2012 Conference (Lima, Peru) also presented a multiplicity of themes and devoted particular attention to natural catastrophes (earthquakes, floods) and climate change, addressing issues linked to the conservation of *World Heritage Earthen-Architectural Sites* (WHEAP) from the perspective of prevention and risk management. The distinction remained between 'living sites' (*Human Settlements and Cultural*

6 See the *Convention for the Safeguarding of the Intangible Cultural Heritage* (UNESCO 2003).

Landscape) and monumental evidence of the past (*Archaeological Sites*), but this separation was in conflict with the definition of "Cultural Landscape" understood as a whole combined works of nature and humankind. In parallel, the mixing of "local knowledge, intangible heritage and social impacts", and that of "ancient/historic and contemporary architecture" created a clash of theoretical positions and aims.

There was a special session devoted to *Charters, Standards and Guidelines for Heritage and Construction* but, in this case as well, it is significant that there was no distinction made between historical architecture and new construction. The conservation of Earthen Architecture was by this point firmly associated with "the safeguarding of the communities that have, *since time immemorial*, handed down traditional knowledge and skills that are still studied and appreciated as examples of low-cost, adaptive and sustainable technology" (Bandarin 2012, pp. 14-15). The chronological vagueness seems to be in step with the prevalent (if not exclusive) focus on economic sustainability and '*adaptive reuse*'. It was followed by the devaluation of cultural heritage from "unique or exceptional testimony" to product to be replicated ("earthen architecture has been recognized for its heritage values and for its intrinsic technical and economic advantages in all regions of the world").

The *Reflections and Recommendations* from 2012 seem fairly generic from the theoretical perspective, but the "Lima Declaration for Disaster Risk Management" deals with the specific theme, highlighting interesting issues (against post-earthquake demolitions carried out in the name of safety; in favour of historical knowledge of past earthquakes). Hope is expressed for greater engagement with other disciplines in order to tackle the themes of materials conservation and technological innovation, in the interest of achieving "change and innovation". The mixing of "continuity of the architectural and construction culture" and "preservation of earthen-architectural heritage" remained. There was some criticism of current research ("the lack of definition of research problems, the repetition and redundancy of research topics, the lack of access to information"), revealing that the methodological premises that had been initially defined (cfr. Torraca 1980) had disappeared: "the existence of different groups, networks, associations ... engaged in earthen architecture" and the need "to promote exchange and collaborative activities, as well as the establishment of an international observatory to define priorities and strategies for research and communication" (Terra 2012, *Reflections and Recommendations*, p. 301).

It seems meaningful that another important International Meeting took place in 2012, spearheaded by UNESCO: *Earthen architecture in today's world* (Paris, France). At this meeting, contemporary earthen architecture was considered for the first time on its own (in the footsteps of Hassan Fathy) and in a way distinct from the World Heritage Sites and Cultural Landscapes. The "World Heritage Earthen Architecture Programme" was illustrated among the *Annexes* (WHEAP 2007-2017).

Of particular interest is the statement that "observing the traditional architecture provides relevant information on the most seismic-resistant structures" since it disproves the widespread overall mistrust, in the event of seismic activity, of historical

building⁷ (Annex 3, p. 256). In this regard, “inventories and the application of available and appropriate documentation tools are needed before, during and after disasters and conflict, to improve risk assessment, response and recovery” (a modern and necessary consideration for architecture in general, not just earthen).

Here as well, we can see frequent confusion between *tangible* and *intangible* values. The statement that “the conservation of the constructive culture of earthen architecture is at the hearth of sustainable development” reveals a greater focus on the ‘building tradition’ to be followed towards the aim of sustainable development, than on the conservation of material/tangible evidence produced by said culture over the centuries.

In the final recommendations, we find concepts that had already been expressed as early as the very first conferences (implementation of exemplary conservation and management projects), but there still seems to be the same confusion between the ‘tools’ and ‘aims’ of conservation (contribute to social and economic development; ... enhance the role of earthen architecture in environmental sustainability and economic and social development). Finally, noting that there are no specifications for Earthen Architecture Heritage in the *Operational Guidelines for the Implementation of the World Heritage Convention*, conclude that “a specialized annex be developed to address conservation guidelines, particularly in relation to *authenticity* and *integrity*, as well as principles for *use*, *interpretation*, and other aspects crucial” (*Appeal*, in Paris 2012, pp. 260-263).

In the *Declaration of 12th Congres Mondial: Terra 2016* (Lyon, France), the ecological motivations for environmental sustainability (use of “bio-based materials”) and the *Sustainable Development Goals* of the ‘2020 Agenda’ still seem to predominate over the cultural motivations that had oriented the first studies on earthen architecture conservation. The aims cited in the *Recommendation* (“to preserve and support the intangible values associated with earthen architecture and its building traditions”) emphasise that ‘intangible values’ seem to prevail over ‘tangible values’ and material conservation; the latter seems to be motivated by use and no longer by the need to protect heritage of cultural interest.

In spite of the call “to focus more attention on World Heritage sites in danger” and despite the noteworthy increase in knowledge regarding the first and second themes of the Conference (Heritage inventories and studies; Heritage conservation and management), the archaeological, historical and technical knowledge of this heritage seems to serve solely “to adapt earth building technologies to new socio-economic realities and evolving production conditions” and, in sum, “to demonstrate the business opportunities that the earth construction sector presents”.

The topics highlighted in the various recommendations for the conservation of earthen architectures are illustrated below (tab. 1).

⁷ See also the *International Workshop for the Recovery of Bam’s Cultural Heritage* (2004).

RECOMMENDATIONS	1972 Iran	1976 Iran	1977 USA	1980 Turk.	1983 Peru	1987 Rome	1990 USA	1993 Port.	2000 UK	2003 Iran	2008 Mali	2012 Peru	2016 Fran.
Moisture e drainage issues			x										
Field lab tests e coordination		x	x	x		x		x					
Traditional materials e techniques based on compatibility and continuous use	x		x	x				x	x		x		x
Excavation protection plans	x	x		x									
Backfilling	x	x											
Protective roof structures/ capping	x	x	x	x									
Application e maintenance of renders	x		x										
Surface treatments	x	x	x										
Maintenance	x	x									x		
Inventory of Earthen Sites					x	x	no recommendations		x	no recommendations			
Establish training centers					x	x		x			x	x	x
Contacts with industrial research						x		x					x
Activation of national committees						x		x					x
Conservation in broader context of social, political issues, planning								x			x	x	x
Sustainable building technologies								x			x		x
Media/didactic materials								x			x		x
Lab research		x						x				x	x
Information exchange system, data bank for research results		x	x	x	x	x		x	x		x	x	x
Utilities upgrade of building in use		x											x
Seismic issues			x					x				x	
Documentation e monitoring								x	xx				
Glossary													

Tab. 1. Summary of the *Recommendations* for the conservation of earthen architecture (cfr. Taylor 2000, 190)

CONCLUSIONS

Today, it seems more important than ever to reaffirm theoretical and methodological reflection on the conservation of Earthen Architecture, since the protection of a substantial heritage of cultural interest is now flanked by other important factors (see the ecological approach and sustainable development in *Agenda 2020*) that, as we have seen, risk predominating over the authentic safeguard of this evidence.

First and foremost, the goals of the conservation of Earthen Architecture need to be clarified: whether it is a matter of preserving architectures of recognised cultural interest (*tangible* heritage), or of transmitting building cultures and traditions that are also important for future development and environmental sustainability (*intangible* heritage).

Both aims are of primary importance, but it is opportune to maintain the distinction between the sphere of conservation of historical earthen heritage and that of new construction, since they are distinguished by different aims. On the contrary, at the most recent conferences the two have always been indistinctly associated. Indeed, the dialectic between conservation and development seems to have created a certain degree of confusion between the aims of safeguarding cultural heritage and those of reclamation and new construction.

Study of earthen architecture has resulted in increasing use of these building traditions both in the recovery of existing architecture and in new construction, but this can create serious problems of authenticity in the area of the conservation of cultural heritage.

Separating the conservation of earthen architecture from the Theory of Restoration — which provides the conceptual bases and guidelines for the authentic conservation of historical evidence — is dangerous and ineffective. Indeed, without the necessary knowledge of the history and the values that the architecture documents, one risks falsifying this material evidence and passing down the historical building methods negating the history itself and the values for which this heritage is recognised to be of 'cultural' interest. In this sense, instead of the implied disciplinary autonomy outlined at the 2008 conference, it would be more opportune to stress the need for an interdisciplinary effort, indispensable for tackling such a complex theme.

As concerns the premises expressed at the first conferences and in spite of the considerable body of knowledge gained in regard to this heritage, what still seems lacking today is a true historiographic approach that makes it possible to frame the phenomenon not only in terms of geography and typology but also in that of chronology. The challenges here are considerable above all because, as has already been observed, it is almost impossible to date this architecture due to its constant reconstruction. Nevertheless, it is precisely for this reason that it seems urgent to rethink the criteria for intervention, in a direction more rigorously conservative and attentive to material authenticity.

BIBLIOGRAPHICAL REFERENCES

- Alçada M., ed (1993), *Terra 93: 7th International Conference on the Study and Conservation of Earthen Architecture* (Silves - Portugal, 24-29 October 1993), Lisbon: Direcção Geral dos Edifícios e Monumentos Nacionais.
- Alva Balderrama A. et Al. (1990), *CRATerre-EAG, ICCROM long-term plan for the preservation of the earthen architectural heritage: The Gaia Project*, in *Adobe 90 Preprints*, Los Angeles 1990, pp. 461-468.
- Alva Balderrama A., Houben H., eds (1988), *5th International Meeting of Experts on the Conservation of Earthen Architecture* (Rome, 22-23 October 1987), Grenoble: CRATerre.
- Avrami E. et al., eds (2008), *Terra Literature Review. An Overview of Research in Earthen Architecture Conservation*, Los Angeles: The Getty Conservation Institute.
- Bandarin F. (2012), *Preface*, in "Terra 2012" 11th International Conference on the Study and Conservation of Earthen Architectural Heritage - 12th Iberian-American Seminar on Earthen Architecture and Construction (Lima - Perù, 22-27 April 2012), Lisbon - Portugal, pp. 14-15.
- Bartolomucci C. (2005), *L'architettura storica in terra cruda: problemi di conservazione e questioni di metodo*, in "Teoria e Pratica del costruire: saperi, strumenti, modelli" (Ravenna 27-29 ottobre 2005), Bologna.
- Bartolomucci C. (2013), *Earthen Architecture: a challenge for the conservation*, in "Recupero e Conservazione", 106, settembre 2013, art. 09 (<https://www.recmagazine.it/magazine/106.html>).
- Chiari G. (1988), *Consolidation of adobe with ethyl silicate: control of long term effects using SEM*, in "5th International Meeting of Experts on the Conservation of Earthen Architecture" (Rome, 22-23 October 1987), pp. 25-32.
- Chiari G. (2000), *Materials and craftsmanship*, in "Terra 2000: 8th International Conference on the study and conservation of Earthen Architecture", Preprints (Torquay, United Kingdom, 11-13 May 2000), pp. 107-114.
- Cooke L. (2010), *Conservation approaches to earthen architecture in archaeological contexts*, Oxford: Archaeopress.
- Correia M. (2006), *The conservation of earthen architecture: the contribution of Brandi's theory*, in "Theory and practice in conservation. A tribute to Cesare Brandi" (Lisbon 4-5 May 2006), Lisboa: LNEC, pp. 233-241.
- Correia M. et Al., eds (2016), *Terra 2012 - Siacot Proceedings*, 11th International Conference on the Study and Conservation of Earthen Architectural Heritage - 12th Iberian-American Seminar on Earthen Architecture and Construction (Lima - Perù, 22-27 April 2012), Lisbon - Portugal.
- Doat P., Verdillon C., (1988), *Preface*, in "5th International Meeting of Experts on the Conservation of Earthen Architecture" (Rome, 22-23 October 1987), p. V.
- Eloundou L., Joffroy T. eds (2013), *Earthen architecture in today's world*. Proceedings of the UNESCO International Colloquium on the Conservation of

- World Heritage Earthen Architecture (Paris - France, 17-18 December 2012), Paris: UNESCO.
- Fidler J., ed. (2002), *Terra 2000: 8th International Conference on the Study and Conservation of Earthen Architecture* (Torquay - Devon, UK, 11-13 May 2000), Postprints, London: English Heritage.
 - Galdieri E. (1996), *Da Yazd al progetto Gaia: storie di una strategia di conservazione*, in F. Storelli (ed), "Habitat e architetture di terra", Atti del Convegno Internazionale (Roma 2-3 dicembre 1994), Roma 1996, pp. 41-46.
 - Grimstad K., ed (1990), *Adobe 90: 6th International Conference on the Conservation of Earthen Architecture* (Las Cruces - New Mexico, 14-19 October 1990), Los Angeles: The Getty Conservation Institute.
 - Guillaud H., Avrami E. (2003), *Research in earthen architecture conservation: a literature review*, in *Terra 2003: 9th International Conference on the Study and Conservation of Earthen Architecture* (Yazd - Iran, 29 November - 2 December 2003).
 - Guillaud H., Joffroy, T. (2016), *Terra Lyon 2016, 12th World Congress on Earthen Architecture* (Lyon - France, 11-14 July 2016), Preprints, CRAterre.
 - Gullini G., Torraca G. (1972), *Rapport general*, in "First international conference on the conservation of mud-brick monuments" (Yazd - Iran, 25-30 November 1972), Paris: ICOMOS, pp. 71-83.
 - Joffroy T. et Al., eds (2018), *Terra Lyon 2016, 12th World Congress on Earthen Architecture* (Lyon - France, 11-14 July 2016), articles selected for on-line publication, Villefontaine - France: CRATerre (<https://craterre.hypotheses.org/1827>).
 - *International Workshop for the Recovery of Bam's Cultural Heritage* (Bam City - Iran, 17-20 April 2004), Declaration and concluding Recommendations, UNESCO-ICOMOS.
 - *Lehm 2004: International Conference on building with earth* (Weimar, Germania, 27-30 Oct. 2004), Dachverband Lehm.
 - *Lehm 2008: International Conference on building with earth* (Weimar, Germania, 9-12 Oct. 2008), Dachverband Lehm.
 - *Lehm 2016: International Conference on building with earth* (Weimar - Germania, 12-14 November 2016), Dachverband Lehm.
 - Piaget J. (1967). *Le système et la classification des sciences*, in Bourguignon, A. "De la pluridisciplinarité à la transdisciplinarité", Congrès CIRET-UNESCO (Locarno, 30 avril - 2 mai 1997), Annexes au document de synthèse.
 - Rainer L. et al., eds (2011), *Terra 2008: the 10th International Conference on the Study and Conservation of Earthen Architectural Heritage* (Bamako - Mali, 1-5 February 2008), Los Angeles: The Getty Conservation Institute.
 - *Recommendations of the US/ICOMOS-ICCROM Adobe Preservation working session*, (Santa Fe - New Mexico, 3-7 October 1977), in "3rd International Symposium on Mud-brick (Adobe) Preservation" (Ankara - Turkey, 29 September 29 - 4 October 1980).
 - *Resolutions* (1972), in *First international conference on the conservation of*

- mud-brick monuments* (Yazd - Iran, 25-30 November 1972), Paris: ICOMOS, pp. 68-70.
- *Resolutions* (1976), in *2nd International Conference on the Conservation of Mud-Brick Monuments* (Yazd - Iran, 6-9 March 1976), Paris: ICOMOS, pp. 265-268.
 - Sāzmān-i Mirās-i Farhangī-i Kishvar, ed. (2003), *Terra 2003: 9th International Conference on the Study and Conservation of Earthen Architecture* (Yazd - Iran, 29 November - 2 December 2003), Teheran - Iran: Iranian Cultural Heritage Organization.
 - Taylor M. R. (2000), *Conservation, maintenance and repair of earthen architecture. Which way do we hold the map?* In "*Terra 2000: 8th International Conference on the study and conservation of Earthen Architecture*", Preprints (Torquay, United Kingdom, 11-13 May 2000), pp. 189-194.
 - Teutonico J.M. (2008), *General Conclusions and Recommendations*, in *Terra 2008: the 10th International Conference on the Study and Conservation of Earthen Architectural Heritage* (Bamako - Mali, 1-5 February 2008), pp. 389-391.
 - Torraca G. (1980), *Introduction*, in "*Third International Symposium on Mud-brick (Adobe) Preservation*" (Ankara - Turkey, 29 September 29 - 4 October 1980), pp. VI-IX.
 - Üstüncök O., Madran E., eds (1980), *Third International Symposium on Mud-brick (Adobe) Preservation* (Ankara - Turkey, 29 September 29 - 4 October 1980), Paris: ICOM-ICOMOS Turkish National Committees.
 - Vargas Neumann J., Mehta P. (1988), *Preservation of adobe constructions in rainy areas*, in in "*5th International Meeting of Experts on the Conservation of Earthen Architecture*" (Rome, 22-23 October 1987), pp. 103-107.
 - 1964, *The Venice Charter*, in "*2nd International Congress of Architects and Experts on Restoration Monuments*" (Venice, 25-31 May 1964).
 - 1972, *Italian Charter of Restorations* (Rome 1972).
 - 1975, *European Charter of Architectural Heritage* (Amsterdam 1975).
 - 1983, *Adobe: International Symposium and Training Workshop on the Conservation of Adobe* (Lima and Cuzco, 10-22 September 1983), Lima: UNESCO, ICCROM.
 - 1985, *Proceedings of the International Symposium on Earth Architecture* (Beijing, 1-4 November 1985), Beijing: Architectural Society of China.
 - 1987, *International Charter for the Protection of Historic Cities* (Washington 1987).
 - 1999, *The Australia ICOMOS Charter for Places of Cultural Significance* (Burra Charter, 1st edition 1979).
 - 2000, *Principles for the Conservation and Restoration of Built Heritage* (Cracovia 2000).

SITES Accessed April 29, 2021

- <https://whc.unesco.org/en/earthen-architecture/>
- <https://whc.unesco.org/en/guidelines/>
- <http://isceah.icomos.org/>
- https://www.getty.edu/conservation/our_projects/field_projects/earthen/index.html
- <https://craterre.hypotheses.org/category/congres-terra-2016>
- <http://www.earthbuilding.info/>
- <https://terra2016.sciencesconf.org/>

PART 2

EARTHEN CONSTRUCTIONS IN ITALY AND CHINA



HISTORICAL EARTHEN ARCHITECTURE IN ITALY

MADDALENA ACHENZA

Department of Civil and Environmental Engineering, and Architecture, University of Cagliari (Italy). ICOMOS-ISCEAH

Keywords: Italy, earthen architecture, historical architecture

INTRODUCTION

In Italy, the use of earth as a building material has been historically well distributed throughout the Country, with the exception of the most mountainous areas in the centre and north of the peninsula. All the 20 political regions, from south to north, from Sicily to Piedmont, attest a diverse but often rich architectural production in which earth represented, in a not very distant past, a very commonly used material. Whether for walls, bedding mortars and plasters, floors and roofs, earth was everywhere used on a more or less large scale.

The different techniques used in the construction of simple units demonstrate the skill developed for centuries in the construction of houses and cities. From the Etruscans (VI-III sec B.C.), who built adobe walls on stone foundations or even on foundations made with the same earth blocks, for both rural and urban buildings and monuments, as well as for the fortifications of their settlements (Baldacci 1958), continuing with the Romans (V-I sec B.C.) who left a considerable number of vestiges throughout the Country, up to the more recent constructions, all of these constitute the historical and traditional earthen architecture heritage of the extended Italian territories.

Few researchers have really studied the role of the earth in the Etruscan architecture, but important documentation indicates its existence through the texts of Pliny and Vitruvius: both mention this material, describe its production, and the monuments still in good condition at their times, in order to demonstrate the quality of their structure and their stability. In particular, Pliny the Elder in his book *Naturalis Historia*, dedicates a whole paragraph to earth construction "*Quid? Non in Africa Hispaniaque e terra parietes, quos appellant formaceos, quoniam in forma circumdatis II utrimque tabulis inferciuntur verius quam struuntur, aevs durant, incorrupti imbribus, ventis, ignibus omniq[ue] caemento firmiores? Spectat etiam nunc speculas*

Hannibalis Hispania terrenasque turres iugis montium inpositas. Hinc et caespitum natura castrorum valis accomodata contraque fluminum impetus aggeribus. Inlini quidem crates parietum luto et lateribus crudis extrui quis ignorat?" (So? Aren't in Africa and Spain walls of earth, which they call clay walls, because they are done in a form surrounded with boards on both sides, they last over time, are not to be destroyed by rains, winds, fires and are more solid of any concrete? Even now in Spain, we see the Hannibal's observatories and earthen towers built on the yokes of the mountains. For this reason, it is adapted as structure to the valleys of the camps and of the riverbanks against the rush of water. Furthermore, who does not know that the surfaces of the walls are smeared with mud and are built with raw bricks?).

From these historical documents we know that different types of buildings were constructed with adobe: many temples, town walls (Arezzo, Gela), tombs (Lipari), *villae* (Roman country villas). Finally, according to a famous quote from Augustus, we can also assume that Rome itself was largely built with adobe: *Marmoream se relinquere, quam latericiam accepisse* (I left a city of marble where I found a city of earth) (Svetonio). During the Middle Ages and thereafter, the use of earth for construction was limited to public housing, as stone was reserved for wealthier families, fortifications and religious buildings. However, we have reason to believe that this material has therefore been constantly used throughout the country for centuries and also during the long period marked by the incursions of Albanians, Greeks and Slavic peoples, in the Marche, Puglia and Calabria. Slavic migrations began at the end of the 14th century, introducing new construction traditions that received a great contribution from the material earth in general, and from adobe in particular. Many places in Calabria where adobe is still in use remind of this period: Spezzano Albanese, Tarsia, Santa Caterina Albanese, Copolati, Crosia, Ghirio, Roccaforte del Greco (Galdieri 1982).

Until the middle of the last century, with a peak following the Second World War, Italy could boast of having many small villages and rural settlements, variously built with earth according to the adobe, rammed earth and cob technology. Distributed in the north, in Lombardy (Lomellina, Oltrepò Pavese, S. Angelo Lodigiano, Mirandolo, Valle Sermeide and Ostiglia in the province of Mantua), in Emilia (Cento), in Umbria (the Umbrian valley from Perugia to Spoleto) in Tuscany (Lake Trasimeno, area of Cortona, Valdarno), in Abruzzo (provinces of Chieti, Pescara, L'Aquila), in Calabria already mentioned, or in Piedmont (plain of Marengo, Frascetta), in Sardinia (Campidano, Cixerri, Sarrabus), in the Marche (provinces of Macerata and Teramo). What remains of this earthen architecture now is an articulated and widespread built heritage that testifies a dignified past and a strong identity but that is slowly being replaced by a unified and generalized way of life, that most of the time overlooks the significance of this inheritance.

The strong heritage protection actions carried out in the last two decades by public administrations, universities and private entities have finally led to many significant actions of conservation in many regions and, in some cases, have sustained new

earth construction. In the following, I will try to provide a concise overview of what earth building represents in those Regions where the remaining heritage is still well recognizable. In some cases, this legacy is more related to the memory of written documents, in other areas earth buildings are still in use proudly showing a living heritage.

THE EARTHEN BUILT HERITAGE IN THE ITALIAN REGIONS

As previously mentioned, not all Italian regions have preserved an evident heritage of earth construction. But for some of them this heritage is still present, and sometimes even still in use, and for some others it has been possible at least to refer to historical documents. In the following, is a description of the heritage of the eight Regions that have been better documented: Sicily, Sardinia, Calabria, Basilicata, Abruzzo, Marche, Tuscany and Piedmont.

Sicily

In Sicily, the unfired brick technique was used in the past for the construction of a large number of Punic, Roman and Greek sites (Fig. 1). There are now numerous archaeological findings that testify earth construction: the city walls of Capo Soprano in Gela (4th century B.C.) are the most impressive evidence of the island (Fig. 2). The walls built around 340 B.C. by the Corinthian general Timoléon, forced to restore and partially rebuild the walls already built 60 years earlier with large blocks (40 x 40 x 8 cm) (Galdieri 1982). Studies conducted by researchers from the University of Palermo led by Maria Luisa Germanà have contributed substantially to highlighting the true Sicilian roots of earthen architecture. From the research carried out on numerous archaeological sites, the findings from different periods, ranging from prehistoric to Roman times, cover different types of buildings: religious, residential, funerary, artisanal, without excluding fortifications (Germanà 2008).

The most interesting archaeological remains, after the VII century BC, when the island opened to non-indigenous influences and when earth constructions began to spread. The earth therefore remains present in the architectural heritage of Sicily until the Middle Ages, with constructions in unfired bricks and rammed earth from the Hellenistic and Roman period. Currently, apart from the archaeological remains, nothing in Sicily reminds about the construction in earth, although there is considerable interest regarding the material and its potential for new building.



Fig. 1 Sicily, Bosco Littorio. Credits: M.L. Germanà



Fig. 2 Sicily, Capo Soprano. Credits: M.L. Germanà

Sardinia

Sardinia represents a special region in Italy thanks to its numerous unfired brick constructions. In this region the earthen house is present in both rural and urban areas (Baldacci 1958).

The island has had a long and continuous tradition of earthen constructions. The remains of the Phoenician and Roman period testify that earth was already a widely used material both for the production of bricks and as a mortar for plasters and floors in stone constructions. The findings in the Punic/Roman city of Nora near Cagliari testify the current use of earth bricks also for representative buildings such as the forum (Bonetto 2012; Bonetto 2013).

Subsequently, the use of earth brick was consolidated during the Spanish domination from 1326-1718 in an area that corresponds to the great Campidano plain which occupies almost a third of the entire island.

This long domination has left a culture that has marked the consistent built heritage still recognizable in the constructive elements and the words that define them as *ladiri* from ladrillo, *tabiccu* from tabique and *boveda* unchanged. In the Campidano everything is built with earth, public and private buildings, industrial and agricultural, urban and rural, rich and poor (Fig. 3 and Fig. 4). Here the adobe technique reached shapes and characters that are rarely found in the rest of Italy, starting from the private house, the most common type, which is always organized around a courtyard. The basic type of the courtyard house can have different forms depending on its location in the specific territories, the economic condition of the family, the particular function: depending on the predominance of one or the other factor, the courtyards can be small or large, placed in front or in the rear, the residential buildings can have one or more levels, face the street or the courtyard. As always, the courtyard houses have a very introverted character, projected towards the internal space where most of the activities take place. Outside, along the access road, often represented by narrow alleys, the surrounding wall runs to protect the intimacy of the family. A sequence of solids and voids, of public and private spaces provides the rhythmic cadence of the inhabited spaces.

At the end of the nineteenth century, another typology appears in small towns, the *palazetto*, built on the street front, a two-story building, open to the public street with large windows and balconies, which escapes the logic ordered by the centrality of the courtyard. These new buildings have an urban character that replicates the model of the noble palaces in Cagliari, the main city of the island. In this case, intimacy surrenders in favour of revealing the family's wealth: stuccoes and external decorations, wrought iron balconies, proudly show the richness of the people who live there.



Fig. 3 Sardinia, Villasor. Credits: M. Achenza



Fig. 4 Sardinia, Musei. Credits: M. Achenza

Calabria

Calabria, with Sardinia and Piedmont, is one of the regions that best represent earth construction in Italy. In ancient times, earth, and the earth brick in particular, were used in Calabria to erect fortifications as evidenced by the remains of ancient Reggio Calabria (6th and 5th century B.C.), Locri and Vibo Valentia (5th century B.C.). The walls of the ancient colony of Region (Ρήγιον), today's Reggio Calabria, were built during the period of Greek domination on the Ionian coast of southern Italy. This defensive structure, discovered at the end of the 1970s, was built in the highest part of the city by ramming a mixture of earth inside two fired brick walls (Galdieri 1982).

The earth brick, used also in modern times until the middle of the last century, is known by different names, depending on the places where it is still present: *mat-tunazzu* (valley of Crati), *bresta* or *vresta* (centre-south of the region), *bisola* (near the strait of Messina). Despite the diversification in terminology, the bricks are manufactured according to identical methods used in historical times and were used both in the countryside and in the urban context until a few years ago (Cavalcanti 1999). Their dimensions vary according to the place of production: around Vibo Valentia and on the plateau of Monte Poro the bricks are larger (38 × 18 × 10 cm), in the valley of Crati and the area of Lamezia Terme, they had a size equal to 30 × 15 × 15 cm, while closer to Reggio Calabria its dimensions are smaller (27 × 14 × 12 cm). Their use is quite diversified involving both rural and urban buildings, both rich and poor.

Although there are no particularly precious decorations as sometimes happens in other countries, it is possible to find very interesting formal and technical applications such as terrace houses, noble palaces, and even industrial buildings and defensive walls. According to a re-organization of the different typologies present, made by Ottavio Cavalcanti and Rosario Chimirri (Cavalcanti 2009), the hut typology is identified which is the most primitive example of agro-pastoral construction. It is a simple and very small space (rarely larger than 7 m²), built with the wattle and daub technique. The cottage, also a rural building, but slightly larger in size, represents the most widespread type in the region. Starting from a single cell, it can have several additional rooms, and an upper floor. The animals and agricultural tools are housed in annexed service buildings.

The walls are made of bricks coated with earth plasters or with lime slurry. The farm, a building type belonging to wealthier families, has a more complex organization, with a central element on two floors around which all other service spaces are organized. This complex of several buildings can accommodate from 50 to 100 people, and can be considered as a small autonomous village, so independent that sometimes it even integrates a small church. Town houses are located within small agglomerations, along historic streets and in the vicinity of religious or military structures. These are basically of two types. The former has a single-storey terrace and has a single room where men and animals live together. The latter, more articulated,

has several rooms for different purposes. It is still possible to find, albeit infrequently, three-storey buildings with artisan shops on the ground floor (Cavalcanti, 1999).



Fig. 5 Calabria, Rural Houses. Credits: R. Chimirri



Fig. 6 Calabria, "Palazzotto". Credits: R. Chimirri

Basilicata

In Basilicata, the construction of earth houses was widely diffused throughout the nineteenth century and during the first half of the twentieth century both in rural and urban areas, for the availability of the materials on site and for the ease of realization of the artifacts (Guida et al 2015).

Now earth houses are no more commonly found, but they are still present in the valleys of Sini and Agri and can be distinguished in two types. The first one is formed by one small room, generally square or rectangular, built at the centre of the property that was cultivated. It was used as a temporary shelter during the day and permanently during the summertime. The second one was a two-storey building and represented the family house in town, built with recurrent typologies. In 1932, De Grazia reported the diffusion in the village of Senise of earthen houses in replacement of those built with stone (De Grazia 1924). These were called *casedda*, had stone foundations and adobe walls (*ciùcioli*): "The dug clay was brought close to the place chosen for building the house. It was broken, pulverized, and then put in a basin where it was wettened and mixed. To the mix wheat straw was added to make it more coherent and insulating, and as soon as the mix hardened, bricks were formed and then sun dried" (Dragonetti 2014).

Floors were made of pebbles or rammed earth, with the use of fired tiles only in rich houses and in town. Sloped roofs protruded from the walls to protect them from rain. Houses were always plastered with one or more layers of lime mix, not just for aesthetic but mainly for sanitary reasons.



Fig. 7 Basilicata, Senise. Credits: W. Secci



Fig. 8 Basilicata, Senise. Credits: W. Secci

Abruzzo

The earthen heritage of Abruzzo is mainly represented by rural buildings, documented since the mid-nineteenth century widespread in the countryside, almost never in the urban area. These are houses with a rectangular or square plan on two levels connected by an external staircase. In urban areas they are houses up to two floors high with walls that can have both raw and fired bricks together.

The ground floor, normally used as an artisan workshop or shop in the city, is used as a barn in the countryside. The use of earth has spread widely in the countryside thanks to its low cost and the availability of the material. Furthermore, the construction process was the result of an exchange of work between neighbouring farmers (Giardinelli 2004).

The most represented technique (95% of cases) is that of the freemason (Conti 2004), characterised by monolithic walls built starting from a clayey earth mixed with a large amount of straw, associated with earth brick only in very rare circumstances. According to a census of earthen houses built by the Abruzzo Region in 1997, it appears that in the areas of Chieti (Loc. Buon Consiglio and Villamagna), there are only 5 houses built entirely with earth bricks. The walls, 40 cm thick, are built with bricks measuring 10 x 12 x 35 cm, the joints and plaster are also made with earth (Gentile 2004).



Fig. 9 Abruzzo, Manoppello. Credits: M. Achenza



Fig. 10 Abruzzo, Manoppello. Credits: A. Lattanzio

Marche

Earth construction is widespread in the Marche, especially in the lower hilly areas and constitutes an important construction tradition in the province of Macerata and in the city of Treia in particular. It has been thought for many years that earth construction was present only in very limited territories (Volpe 2004). In fact, more in-depth research conducted over the last few decades by architects Gianni Volpe and Anna Paola Conti have brought to light many buildings, the most recent of which date back to the late 19th century. These buildings known as *atterrati* (literally in dialect: built in earth) were rural buildings as well as urban ones. The walls were mainly made with almost pure clay with a technique called *massone* (cob, in English), more rarely with bricks. It is worth mentioning the exceptional example of a neighbourhood built almost entirely with earth bricks now incorporated into the town of Macerata, but once a rural agglomeration, Villa Ficana (Conti 2002). It is a set of about fifty terraced houses, some of which have a mixed technique of cob and adobe. The analysis of the existing building demonstrates a masterful knowledge of mason construction and detects the presence of unfired bricks prepared without straw, especially used for internal partitions (Giustozzi 2007).



Fig. 11 Marche, Treia. Credits: A. P. Conti



Fig. 12 Marche, Villa Ficana. Credits: A. P. Conti

Tuscany

Tuscany is not a region of Italy that immediately evokes earth construction, but this material has been widely used in the region, especially in some areas, like those of Val di Chiana around Lake Trasimeno and in Valdarno. It is important to remember the well-known booklet by Giuseppe del Rosso (Del Rosso 1793) (Bertagnin 1992) which extensively describes the earth constructions in those territories. However, there are documents that refer to defensive structures built with rammed earth, and sometimes even with earth bricks. In the third century BC, during the transition period between the Etruscan and Roman domination, part of the walls of the ancient Arretium (Arezzo) was rebuilt using large rectangular unfired bricks measuring 48 ×

28 × 12 cm. These bricks had a particularity described by G. Lugli: “the bricks of the wall are made with a not very refined clay that contains stones without added straw; these were first dried in the sun, and then lightly passed over the fire, but their interior remained mostly raw due to their great thickness” (Lugli 1952). The semi-firing process has given these bricks the same shiny surface appearance of the Assyrian walls and represents in our eyes the transition phase from raw to fired brick (Galdieri 1982). Another interesting example is the Villa Settefinestre, built on a hill near Cosa, an important Roman maritime commercial port founded in 273 BC, sited along the Via Aurelia near Argentario promontory.

The villa was built in 40 BC by a family linked to the Roman Senate and had a property of 125 ha used for agriculture and livestock. Certain parts of the building made of earth prove that a good part of the Roman republican buildings used this material. What remains in Tuscany today is a limited heritage and almost unknown, essentially concentrated in the south of the region, with rare but not unimportant urban presences. This is the case of San Giovanni Valdarno where are still visible, in the historic centre of the city a group of houses perhaps designed by Baldassarre Buontalenti (1536-1608) made of unfired bricks (Galdieri 1982).

A recent uncovering is the one inside the Grange of Cuna near Monteroni d’Arbia, a big farm owned by the Santa Maria della Scala Hospital in Siena. Among the different masonries, fired brick masonries with earthen bedding mortars have been found in the original medieval nucleus, while rammed earth masonries plastered with lime mortar are present in some late medieval or post-medieval additions (Giamello 2016). Moreover, two examples of rammed earth masonries yet in the territory of Siena were reported by Parenti (2002): the Palace Bandinelli Corboli in Asciano (in the second building phase, dating to the 13th century) and Castelverdelli (San Giovanni d’Asso), where the earthen walls, made with different techniques, are largely used in the large complex, related to the 13th-14th centuries (Fratini 2020).



Fig. 13 Tuscany, Alberoro. Credits: M. Achenza (1993)



Fig. 14 Tuscany, S. Giovanni V. Credits: E. Desantis

Piedmont

Although there is no specific documentation of earth archaeological findings in the region, Piedmont is one of the richest Italian areas in earth constructions. The heritage still visible today mainly dates to the past two centuries even if it is still possible to find more ancient buildings. Many earth constructions are concentrated in an area between Alessandria, Novi Ligure and Tortona, the so called Marengo plain, where rammed earth coexists with brick construction to form an architectural presence of great diffusion and importance.

The shape of the buildings varies according to their destination. Sometimes these are residential block buildings such as in the cities of Alessandria and Novi Ligure or smaller units, as in the case of Bosco Marengo, Frugarolo and Spinetta Marengo. But also rural houses are numerous throughout this area. In the remaining part of the Alessandria province the use of earth bricks is widespread their presence characterizing many small towns such as Fresonara, Castelnuovo Bormida, Castellazzo and Basaluzzo.

Studies conducted over the last decade have shown the presence of interesting examples of earth architecture also in the provinces of Asti, Torino, Biella and Cuneo (Fratini 2020). In these buildings the use of earth brick does not exclude the employ of fired bricks and they may coexist. In some cases, in fact, earth bricks are

found only in the upper floors immediately below the roof that protects it from the elements, while in other cases the fired bricks are used for the bearing structures and earthen bricks for internal and external walls. The fired brick can be also found only as a decoration (Robboni 2007).

For the most part, these earth bricks architecture is represented by isolated houses, very simple in shape, almost always with two floors, more rarely with the addition of a mezzanine attic. In the urban context the buildings are adjacent with large façades on narrow streets or small squares, windows only starting from the first floor and open only to the back. These two or three storey buildings do not differ at all from the more recent buildings built next door, which have maintained the shapes and decorations of the earth buildings.



Fig. 15 Piemonte, Novi Ligure. Credits: I. Parodi



Fig. 16 Piemonte, Novi Ligure. Credits: G. Bollini

CONCLUSIONS

The diffusion of earth buildings in Italy has been very extended in ancient times in the whole country, as evidenced by the most recent archaeological campaigns. Nowadays, even if there are no significant concentrations of earthen buildings left, except in some regions described above, earth as a building material, where present, is well recognized and mostly still in use. In these regions, the use of earth as building material has sometimes reached such levels of exceptional skill, sobriety and richness that the heritage has survived despite almost a century of neglect and abandonment. These constructions and the culture that they bear are still far from being put at the centre of political actions of conservation and valorisation, but some activities at national level were carried out in order to frame a dedicated normative in the years 2004-2009 and several Regional laws have stated the need to recognize, preserve and valorise the local earthen built heritage.

The pandemic events of the last months seem to put this heritage again under a focus lens, as the Italian villages, the very backbone of the country, are places where people live better and differently from large cities, on a human scale; they are places of thought and slowness, that same slowness that very well represents the figure of Italian artisans, of high quality agriculture, of the protection of biodiversity, of the landscape suspended between city and countryside, between sea and hinterland. These are concepts that need to be protected and spread in order to make the living in these peripheral places more and more attractive. Famous architects as Stefano Boeri and Massimiliano Fuksas are convinced that the rehabilitation of old minor villages will be our future, able to stop the diffused uncontrolled soil consumption and to assure energy efficiency, enhance circular economies, both key instruments to respond to the climate and the pandemic crisis we are facing.

BIBLIOGRAPHY

- Baldacci O. (1958). *L'ambiente geografico delle case di terra in Italia*. Rivista geografica italiana LXV, Num. spec. Studi geogr. in onore R. Biasutti pp.13-44.
- Bertagnin M. (1992). *Il pisé e la regola. Manualistica settecentesca per l'architettura in terra*, Edilstampa, Roma.
- Bonetto J., Falezza G., Ghiotto A.R., Savio L., Tabaglio, M. Zara A. (2012). *Il Saggio PR3. Campagne di scavo 2009-2010*, in Quaderni Norensi IV, pp. 155-183.
- Bonetto J. (2013). *L'insediamento fenicio di Nora e le comunità nuragiche: contatti e distanze*, in P. Van Dommelen, A. Roppa (edd.), *Materiali e contesti nell'età del ferro sarda*, Atti della giornata di studi, Museo civico di San Vero Milis (Oristano), 25 maggio 2012, Rivista di Studi Fenici, 41/1-2, pp. 173-182.
- Cavalcanti O., Chimirri R. (1999). *Di fango, di paglia... Architettura in terra cruda in Calabria*, Rubettino Ed., ISBN 8872847877.

- Conti A. P. (2002) *Il recupero di una casa di terra*, Edicom Edizioni, Monfalcone.
- Conti G. (2004). *Viaggio nella terra cruda in Italia*, ed. Tinari, Villamagna (CH).
- De Grazia P., *Lucania e Basilicata. Contributo al problema della divisione dell'Italia in regioni e provincie*, vol XXXI (1924), pp. 213-232.
- Del Rosso G. (1793). *Dell'economica costruzione delle case di terra, opuscolo diretto agli'industriosi possidenti e abitatori dell'agro toscano*; Bouchard, Firenze.
- Dragonetti P. (2014). *Terra mediterranea. Il richiamo alla sostenibilità attraverso la promozione delle case di terra*, ed Ceged, EAN: 9788890541360, available at www.terramediterranea.com.
- Fratini F., Mattone M., Rescic S., Rovero L. (2020) "Analysis of the earthen architectural heritage in Piedmont (northern Italy): typologies, construction techniques and materials", Gremium©| Volumen 7 | Número 14 | August-December 2020, pp. 101-112.
- Gaio Plinio II il Vecchio, *Naturalis Historia*, libro XXXV, p. 169.
- Galdieri E. (1982) *Le meraviglie dell'architettura in terra*; Laterza, Roma-Bari, 8842020656.
- Gentile P. (2004). *Il censimento delle case di terra in Abruzzo*, in Conti G., *Viaggio nella terra cruda in Italia*, ed. Tinari, Villamagna (CH).
- Germanà M.L., Panvini R. (2008). *La terra cruda nelle costruzioni. Dalle testimonianze archeologiche all'architettura sostenibile*; Nuova Ipsa, Palermo, ISBN 9788876763793.
- Giamello M., Fratini F., Mugnaini S., Pecchioni E., Droghini F., Gabbriellini F., Giorgi E., Manzoni E., Casarin F., Magrini A., Randazzo F., (2016) "Earth Masonries in the Medieval Grange of Cuna – Siena (Italy)", *Journal of Materials and Environmental Sciences*. 7 (10), 3509-3521.
- Giardinelli S., *Stato dell'arte dell'architettura in terra in Abruzzo*, in P. Gentile, *Il censimento delle case di terra in Abruzzo*, in Conti G., *Viaggio nella terra cruda in Italia*, ed. Tinari, Villamagna (CH) (2004).
- Giustozzi S., *La terra cruda e gli atterrati*, in A.P. Conti (a cura di), *Il recupero di una casa di terra*, Edicom Edizioni, Monfalcone (2002).
- Guida A., Mecca I., Forlenza G. (2015) *La terra cruda in Basilicata tra memoria tradizione e conservazione*, in XI CIATTI 2014. Congresso Internacional de Arquitectura de Tierra Cuenca de Campos, Valladolid, e-print, ISBN: 9788460695431.
- Lugli G. (1952). *La tecnica edilizia romana*, G. Bardi editore, Roma.
- Parenti R., *Il "chasamento" dei Bandinelli ad Asciano e Castelverdelli nella Val d'Asso*, in *Le dimore di Siena, l'arte dell'abitare nei territori dell'antica Repubblica dal Medioevo all'Unità d'Italia*, ed. Morolli G., Firenze, Alinea (2002), pp. 107-112.
- Robboni F.C. (2007), *Terra rossa: le case della Frascetta*, ed. Spinetta Marengo.
- Svetonio, *Vite dei Cesari*, Aug., XXVIII, 3.
- Volpe G., *Le costruzioni di terra nelle Marche settentrionali*, in P. Gentile, *Il censimento delle cose di terra in Abruzzo*, in *Viaggio nella terra cruda in Italia*, a cura di G. Conti, ed. Tinari, Villamagna (Ch) 2004.
- XIV LEGISLATURA. House of Representatives - N. 2347. Bill of initiative of the

- deputy Marco Lion. Amendments to the law 2 February 1974, n. 64, containing provisions for buildings with prescriptions for seismic areas, presented on February 14, 2002.
- The Unified Text. Provisions for earth constructions (C. 2347 Lion and C. 4019 Cossa). Proposal for a Unified Text prepared by the Rapporteur based on the work of the Select Committee. Provisions for earth constructions.
 - XVI LEGISLATURE – Preparatory work sheet. Parliamentary act: 2358 (Fase iter Camera: 1[^] lettura). Dep. Schirru Amalia. Provisions for the promotion of earth constructions. April 2, 2009: Presented to the Chamber. To be assigned to the commissions: Schirru Bill - "Provisions for the promotion of earth constructions" (2358).
 - XIII LEGISLATURE – Law proposal n. 47. Presented by the Regional Councilors: Calleda, Marrocu, Barracciu, Cherchi, Corrias, Cugini, Floris Vincenzo, Lai, Mattanna, Orrù, Pacifico, Pirisi, Sanna Alberto, Sanna Franco, on October 20, 2004. Provisions for the protection, recovery and the enhancement of the architectural heritage made with earthen artefacts and construction techniques and for the promotion of new bio-ecological building productions.

EARTHEN HOUSES IN ABRUZZO REGION (ITALY)

SILVANO AGOSTINI¹, GIANFRANCO CONTI²

¹ *Superintendence of Archeology, Fine Arts and Landscape (ABAP) of Abruzzo Region, Geological and paleontological service, Chieti, Italy*

² *Terrae non-profit association; CEDTerra, Italy*

THE "EARTH"

The eastern side of the Apennine chain of Abruzzo reaches the Adriatic Sea through a complex hilly landscape, whose environmental context is marked by remarkable geodiversity, with sandy and clayey sandy hills sediments of Middle Pliocene-Pleistocene age, the so called "sub-Apennine clays" (Fig. 1). Local communities indicate these sediments with the term "earth". This material, which is widely available, has been used in the past as unfired material in the construction of houses. Only later and progressively the houses have been built with fired bricks, first produced in pre-industrial single chamber kilns and then in modern industrial kilns. Nevertheless at present earthen materials are still used in architecture. From the compositional point of view the "earth" consists of a mixture of phyllosilicates (with prevalence of illite and smectite), associated with silt and a low percentage of fine sand. The amount of calcium carbonate, both as a debris fraction and as a cement, is considerable. These sediments have a marine origin, being deposited in a submerged platform environment. Their sequences are formed by layers of sub-metric thickness organized in regular morphostructures according to a monoclinical arrangement with dip direction towards E-NE. The natural exposure of these sediments is visible along the river incisions or where the slopes are deeply eroded (Fig. 2). The weathering and the intense erosion processes of these sediments leads to the formation of alteration outcrops of variable thickness (up to more than 5 meters).

The harmony between the earthen houses, the geometries of the agricultural fields, together with the hilly morphology of the sub-Apennine clays, represents a rural landscape of considerable historical and environmental value, closely related to the traditions and cultures of local communities.

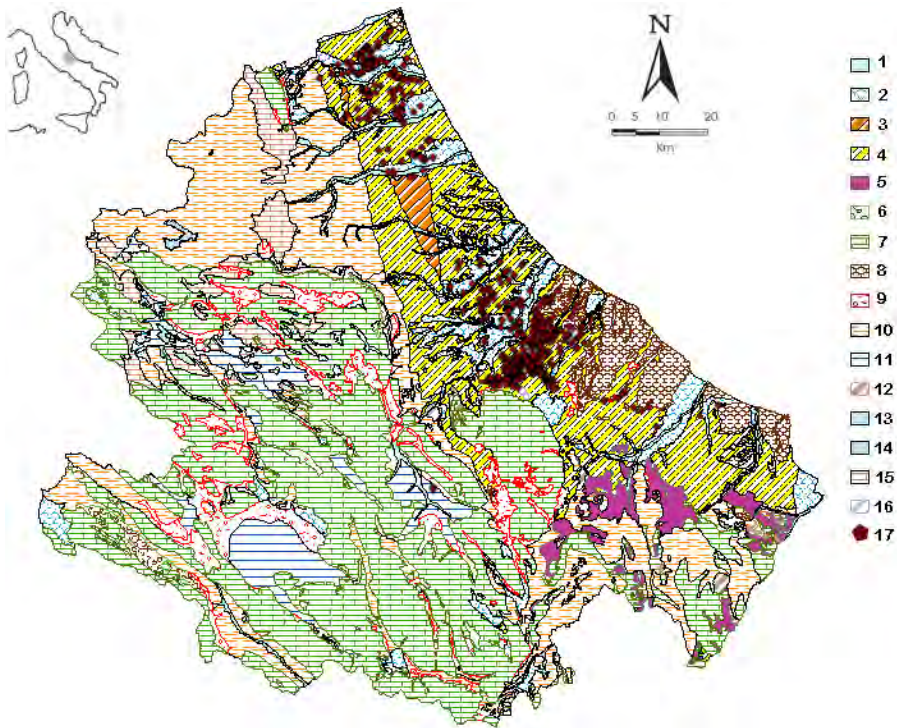

Fig. 1 Map of landscape units and houses of earth in Abruzzo

Symbol Legend

1- Alluvial flatlands (Holocene); 2- Alluvial flatlands (Pleistocene); 3- Hills of sandstones, sands and conglomerates (Plio-Pleistocene); 4- Clay hills (Plio-Pleistocene); 5- Reliefs and hills of marl, clays and chinks of the allochthone units of the Molise basin (Upper Cretaceous-Upper Miocene); 6- Carbonate reliefs (Lower Jurassic-Middle Miocene); 7- Transitional facies (sands and conglomerate) flatlands (Pleistocene); 8- Debris flow deposits and alluvial fan (Pleistocene – Holocene); 9- Reliefs of sandstones and marls of turbiditic flysch (Middle-Middle Pliocene Miocene); 10- Lacustrine basins intermountain, clays, silts and gravels (Pleistocene); 11- Hills of marls and chinks (Upper Miocene); 12- Lakes; 13- Artificial lake; 14- Hills and terraces of travertine and calcareous sands; 15- Houses of earth.



Fig. 2 The hilly clay landscape of Abruzzo near Bucchianico (Chieti) - Coste dello Spagnolo

THE "SURVEY" OF THE EARTHEN BUILDING IN ABRUZZO

Abruzzo earthen buildings are mainly rural houses that contribute to delineate the agricultural hill landscape made up of multiple signs of delimitation of agricultural spaces, reflecting the breakdown of land ownership. The survey project, carried out by the Abruzzo Region in 1999 (Cicchitti et al. 1999; Perrotti et al. 1999), entitled "Earthen houses: diffusion of settlements in Abruzzo", identified the presence of 806 earthen buildings on the whole regional territory, divided into 44 municipalities with respect to almost 7000 earthen buildings that were detected in 1934 in a "Survey on rural houses in Italy" (Ortolani 1961). These buildings are located mainly in two areas: the first including the valleys between the rivers Vibrata, Vomano, Tordino and Salinello (province of Teramo) and the other including the Val Pescara and Val di Foro (provinces of Pescara and Chieti).

The most conspicuous earthen building heritage in the whole of Abruzzo was identified in Casalıncontrada (province of Chieti) with 124 buildings, followed by the municipality of Manoppello (province of Pescara) with 92 and the municipality of Chieti with 84. The presence of earthen building dates back to the end of XVIII century and the second half of the XIX century, a period in which the crisis of the

feudal system and a strong demographic increase occurred at the same time (AA. VV., 1986). The consequence was the splitting of the agricultural property and the pressing necessity of a large number of farmhouses. The choice of the earth as a building material turned out to be the most easy self-construction system, based on the use of the available materials (Fig. 3). The update of the "survey", carried out on some selected Municipalities (Casalincontrada and Manoppello) after 1999, indicates a reduction of 20% of the existing earthen building heritage.



Fig. 3 Historical image of the early XX century: first phase of the earthen construction with the technique of the "massone"

THE BUILDING TECHNIQUES

It is a matter of fact that man has always been able to build with the earth, whatever was its composition, seeking and recognizing in the surrounding environment, when necessary, every possible additive: straw, animal dung, the mucilage of "succulent" plants, etc. Where the use of earth has become, over the time, a true and continuous tradition, specific technologies have developed, often sophisticated and aimed at improving its static performances, expressive possibilities and living comfort. The "earth", therefore, as local raw material, has been adapted by man to the particular needs of living in that specific site, according to particular building techniques. In Abruzzo and Marche the most widespread technique is "massone" that in the European context can be referred to the "cob" technique ("bauge" in French). This technique requires "earths" with a good clay content, at least 40-50 % (Fig. 4). This technique consists in the construction of buildings through the simple

overlapping of small blocks of wet earth, very often mixed with straw. After drying, the resulting wall presents a continuous structure, compact and without cavities, due to the complete connection of the individual constituent elements. The construction of the house is done by tracing the perimeter of the external walls through the digging of a trench 30-40 cm deep; from this trench, after having compacted the walls, starts the elevation of the masonry that is realized according to rings 60-80 cm height and thickness ranging from 60-80 cm (in buildings limited to the ground floor) up to about 100 cm or more in those with two floors. After the realization of each ring, the construction is interrupted to give a time of settling to the material. Then, the top layer of the masonry is wetted and a further ring is realized but with a different attachment point along the ring. This procedure, aimed at generating a monolithic and compact masonry, guarantees the continuity and homogeneity of the structure. The finished wall on the outside is progressively tapered upwards (Bertagnin 1999, Morfini 1995).



Fig. 4 Restoration site: kneading of the earth for the "massone" technique

RECOVERY PROGRAMS

Despite the decrease in the existing earthen building heritage, for the first time in recent years, even if with difficulty, we are in presence of systematic work of recovery implemented and favoured by regional laws but above all by the obstinacy of a group of professionals. In fact, they convinced the owners of the earthen buildings of the historical, landscaping, anthropological and cultural value of their houses and of the possibility of recovering them for receptive purposes.

A pilot significant experience, which preceded the current restoration and recovery projects, was the restoration of the D'Orazio house in Casalıncontrada, which started in 1997 and ended in December 2004 with the return of the D'Orazio family to the their earthen house, thereby demonstrating that *"with the earth we can"* (Giardinelli 2000). Today the in progress works of recovery concern 13 houses in the municipalities of Bucchianico, Casalıncontrada, Manoppello and Roccamontepiano. The recovery works have been financed by the Regional Law n. 64/99 that promoted Urban Recovery Programs.

An association, consisting of the aforementioned municipalities, which form part of a homogeneous hilly area located on the borders of the urban area of Chieti, responded to the competition announcement. These earthen buildings, after restoration, which will take place without changing their formal and material characteristics, will be re-implemented in a project called *"diffused hotel"*, for receptivity in traditional buildings (Figg. 5-6). In the restoration projects, the problem of the compliance of these constructions with seismic regulations was also tackled for the first time.

The last restoration project in Abruzzo involved the *"Teresa's house"* visitor centre, a local office of the *"Centre for permanent documentation on earthen houses"* (CEDTerra), created on the initiative of the Municipality of Casalıncontrada and recognized with the Regional Law n. 44/92 *"Regulations regarding museums of local authorities and local interest"* and today also Centre for Environmental Education (C.E.A.). The visitor centre *"Teresa's house"* is a permanent non-profit institution, open to the public, which through the direct involvement of the inhabitants, promotes and works for the protection, conservation, interpretation, enhancement and transmission of the architectural, historical, cultural, ethnographic and anthropological heritage of Casalıncontrada earthen buildings, in its material and immaterial manifestations, with a view to sustainability (Figg. 7-11).



Fig. 5 Casalincontrada (Chieti) Borgocapo: earthen building before restoration



Fig. 6 Casalincontrada (Chieti) Borgocapo: earthen building (Fig. 5) after restoration



Fig. 7 Casalincontrada (Chieti): Teresa's house, before restoration



Fig. 8 Casalincontrada (Chieti): Teresa's house, restoration of the walls



Fig. 9 Casalincontrada (Chieti): Teresa's house, application of earthen plaster



Fig. 10 Casalincontrada (Chieti): Teresa's house, after restoration



Fig. 11 CasalINTRADA (Chieti): Teresa's house, the interior after restoration

NEW BUILDINGS AND NEW USES

At present, the only example concerning an intervention in a public earthen building is the enlargement in 2002 of a building belonging to the Municipality of Roccamontepiano. This project involved the activation of a complex process that at the same time envisaged both the project and the organization of the production process for the supply of the material necessary for the construction.

Another experience was the set-up of a showcase at the "La Civitella" archaeological museum in Chieti, built in 1998 utilizing earth according to different techniques, from the pisé, to abobe and earthen plaster coloured in paste. This intervention was important in order to testify how the use of earth material is also possible in different forms like the realization of furniture and finishing. The earth was preferred because it was the material that best met the need to represent, as an example, an archaeological stratigraphic section and that better suggested the hilly landscape of Chieti territory. Taking into account that there is no tradition in the use of earth for the finishes, the work carried out at the museum "La Civitella" of Chieti was an example, to see and touch, which subsequently facilitated the proposals of earthen plasters.

THE CENTRE OF DOCUMENTATION OF EARTHEN HOUSES (CEDTERRA)

All the activities described were systematized thanks to the birth, in 1992, of the centre of permanent documentation on Earth Houses (www.casediterra.com), promoted by the Municipality of Casalincontrada, and recognized in 1993 by the Abruzzo Region.

The objectives of the centre are to disseminate the knowledge of the earth as a building material, to assist the research in the sector and to enhance the existing earthen buildings heritage and the new earthen constructions. The main event organized for the dissemination program is the "Earth Festival", a meeting event for national and international experts and lovers of earth, organized since 1997 and arrived today at the XXIV edition. These meetings have improved the birth of a network of Italian universities that conduct research on earth in architecture. The "Earth Festival" also contributed to the birth of the International Association of Earthen Cities (www.terraocruda.org). A side event of the "Earth Festival" is the photographic competition "The earthen houses - landscape of architectures", now in its 18th edition. The competition allows the collection of representative images of the international heritage of earthen buildings.

TRAINING ACTIVITIES

Training initiatives began with a workshop organized in 1997 with the Building School Authority of Chieti. The school included a week of specific construction yard on earthen buildings, just on occasion of the restoration of the D'Orazio house. The workshop allowed a group of 15 future masons to acquire a first knowledge of the earth as a building material.

This activity, promoted by the Terrae non-profit association and the Building School of Chieti is followed every year, since July 2001, at Casalincontrada, by other training seminars on the knowledge of the earth material, on the "massone" and adobe construction techniques and on the project of earthen buildings (Fig. 12). An example of the practical application of the methods was the recovery of the D'Arcangelo house. Furthermore, the involvement of schools and teaching for local children is very important in training activities.



Fig. 12 Participants in a training workshop organized by CEDTerra and the Association Terrae onlus

BIBLIOGRAPHICAL REFERENCES

- AA.VV. (1986) *“Le case di terra nel territorio abruzzese”*, Museo delle Genti d’Abruzzo, n.12, Arti Grafiche Garibaldi, Pescara, pp. 1-39.
- Bertagnin M. (1999) *“Architetture di terra in Italia. Tipologie, tecnologie e culture costruttive”*, Edicom edizioni, Monfalcone, pp. 53-64.
- Cicchitti M., Fiadone F., Gentile P. (1999) in AA.VV *“Terra cruda. Insedimenti in provincia di Chieti”*, COGESTRE, Penne (PE), pp. 43-62.
- Giardinelli S. (2000) *“Il restauro di casa D’Orazio”*, in M. Achenza, A. Sanna (a cura di), *Abitare la terra. Atti del Convegno. Villamassargia – Samassi 12-15 Novembre 1998*, CUEC, Cagliari, 2000, pp. 103-105.
- Morfini L. (1995) *“Terra cruda in Manuale di progettazione edilizia”*, vol. 5, Ed. Hoepli, Milano, pp. 84-85.
- Ortolani M. (1961) *“La casa rurale negli Abruzzi”*, L.S. Olschki, Firenze
- Perrotti A., Pisano P., Cicchitti M., Fiadone F., Gentile P., Vaccarini G. (1999) *“Case in terra cruda. Diffusione degli insediamenti in Abruzzo”*, Regione Abruzzo-Assessorato all’Urbanistica, Beni Ambientali, Parchi, Riserve naturali, Cultura, L’Aquila, Vol.1, pp. 12-16, 20/27-31.

THE STATUS OF EARTHEN SITES IN CHINA

GUO JUWEN

Chinese Academy of Culture Heritage - CACH, Beijing, China

Keywords: Chinese earthen sites, earthen construction techniques, earthen artefact decay

INTRODUCTION

Earthen sites, simple architectural structures built with earth as the main material, provide great historical, aesthetic, scientific, social and cultural insights into our human heritage ¹(Wang, 2008). As one of the most ancient civilizations in the world, China has a long and fascinating culture and history. The ages of earthen sites in China vary greatly, dating from the Stone Age to modern times: - the Liangzhu site in the middle and lower course of the Yangtze River, the birthplace of Chinese civilization; - the Erlitou site of the Xia dynasty, the first dynasty in traditional Chinese history; - the Yin Ruins of the Shang Dynasty; -the ruins of Jiaohe, Gaochang, Loulan and Niya, ancient cities in the Xinjiang section of the ancient Silk Road; - the Great Wall in the north and its ancillary facilities such as the Gate Fort, the Beacon Tower and so on. These earthen sites highlight the creativity and national spirit of the ancient Chinese people, teach us a great deal about Chinese history, and testify to the beauty of Chinese culture. They have irreplaceable value and status because of their long history, varied designs, and vast territories upon which they are found. However, due to being exposed to weathering for thousands of years and to the intensification of human activities in recent generations, many of these earthen sites are not well preserved. Based on the collection and comparison of relevant literatures on the protection of earthen sites, this paper summarizes the status of Chinese earthen sites including the distribution, types, raw materials and construction techniques, as well as the description and classification of the decay phenomena affecting them.

1 China National Committee of the International Council of Monuments and Sites, Guidelines for the protection of cultural relics and historic sites in China (only Chinese version), Cultural Relics Publishing House, 2015.

DISTRIBUTION OF EARTHEN SITES

Chinese earthen sites are widely distributed throughout the country. According to public data about cultural relics under state protection in 2013, there are 1072 earthen sites, accounting for nearly 30% of total units. Statistically earthen sites are a very important part of the cultural heritage of China. The distribution of existing earthen sites in China began from Stone Age to Ming-Qing Dynasty and even can be found in modern China. The original village Banpo site of Yangshao period in Xi'an, the pit site of the Qin Terracotta Army in Lintong, the Dadiwan site in Qin'an, Gansu, the Great Wall Ruins from the state of Qin in the Warring States Period in Dingxi area, Yumen Pass and the Great Wall of Han Dynasty in the outskirts of Dunhuang, the mausoleum of Xia Dynasty in Ningxia and the Great Wall of the Han Dynasty in Shanxi are only some of China's most famous sites.



Fig. 1 Distribution of earthen sites recognized as the State-level Cultural Relics Protection Units in the Chinese provinces

TYPES OF EARTHEN SITES

Chinese earthen sites are very rich in varieties. Earthen sites can be grouped according to several different methods of classification. They can be sorted on appearance and functionality: ancient residential sites, ancient cities, sections of the Great Wall, passes, beacon towers and earth towers, mausoleums, unearthened pits, caves, kilns, cellars, stratigraphic sites of ancient fossil, among other things. They also can be divided into open sites and indoor sites based on their level of external exposure. They can also be classified according to their surroundings, whether they were built in an arid region or a humid region. Due to environmental changes after excavation, they can be divided into superficial and subsurface earthen sites. Even further distinctions can be made based on the construction process: sites can be divided into raw earth, rammed earth, adobe, cob and other types. The classification of earthen sites in the State-level Culture Relics Protection Units in China include ancient sites, ancient tombs, and modern buildings, and among them, ancient sites and ancient tombs account for the majority (Wang, 2013).

1. Hominid site

Hominid sites are widely distributed in China, covering the Yangtze River basin and the Yellow River basin. At present, there are more than 10,000 known Neolithic sites and nearly 1,000 of them have been excavated (Sun, 2010). Usually Neolithic sites encompass well-preserved residences or burial places, with an area ranging from tens of thousands to millions of square meters. For example, the Banpo Site in Xi'an and the Jiangzhai Site in Lintong are composed of residential areas, pottery workshops and tombs. The Pingliangtai Ancient City Site in Huaiyang, Henan Province is the earliest urban relics in China to date.

2. Ancient city

Ancient city sites consist of walls, foundations, and cave dwellings built from raw earth, according to different techniques like rammed earth, adobe and stacked mud. For example, the Yin Ruins of the late Shang Dynasty in Anyang, Henan Province includes areas devoted to ancestral temples, palaces, mausoleums, handicraft workshops, civilian residences and tombs. Its total area is about 30 square kilometres. The Loulan ancient city of Han Dynasty was a transportation hub in the centre of Asia along the ancient "Silk Road". It played an important role in the cultural exchange between the East and the West.

3. Great Wall, pass, beacon tower and earth tower, etc.

The Han Great Wall, Yang Pass and Yumen Pass are considered the most iconic of all Chinese earthen sites. The Yumen Pass is located in the Gobi desert 80 kilometres northwest of Dunhuang city in Gansu Province. It is the only pass along the northern route of the ancient Silk Road. The remains of its existing city walls are generally

rectangular. They are all made of loess and enclose an area of 663 m². There are doors on the west wall and the north wall, as well as an east-west lane under the northern slope of the city. Historically, this area served as a road for communication and postal servicing between the Central Plains and the Western Regions.

4. The mausoleum

Tombs of ancient emperors are widely distributed throughout China. The mausoleum of XiXia Dynasty in Ningxia, the mausoleum of the first emperor of Qin in Shaanxi, and the tomb of the kingdom Guo in Sanmenxia, Henan are all very famous historical sites.

5. Sites of ancient fossil strata

There are more than 200 architectural sites in China containing Paleolithic human fossils, which are found in several different types of locations. Some, like Yuanmou man in Yunnan, were discovered near rivers or lakes. Others, like Lantian man in Shanxi, were scattered among the soil. And others, like the Peking man of Zhoukoudian, were found in a cave.

6. Sites of ancient handicraft industry and mining and metallurgy site

In a lot of ancient Chinese industrial sites, archaeologists found kilns for firing porcelain, and also unearthed a large number of kiln furniture pieces and defective porcelain. Representative kiln sites include the Shanglinhu Yue Kiln Site of Eastern Han Dynasty in Cixi, Zhejiang Province, the Longquan Kiln Site of Song Dynasty in Zhejiang Province, the Jun Kiln Site in Henan Province, and the Ru Kiln Site at Qingliang temple, Baofeng, Henan.

In addition to places that produced pottery, there are also locations that processed ores. Mining and smelting sites include the Tonglushan bronze mine site in Daye, Hubei, and the iron-making sites of Han Dynasty in Gongxian, Henan Province.

7. Other

There are many other remains of earthen sites, such as the canal of Zheng Country site in Shaanxi province.

CONSTRUCTION TECHNIQUES OF EARTHEN SITES

The construction techniques of the earthen sites are roughly divided into five categories: excavation, rammed earth, stacked mud, adobe masonry and raw earth block masonry. (Shenet al., 2011)

The excavation method was used to create architectural structures by digging into the earth. (Zhanget al., 2008). Excavation sites include crypts, semi-crypts, cave-style buildings, courtyard buildings and ruins of ancient cities. In northern China, many

early housing structures were found partially underground, such as the 7000-year-old Cishan mountain cultural relics in Hebei, the Peiligang cultural relics in Henan, the Dadi Wan site in Qin'an, Gansu Province and the Xinle Site in Shenyang, Liaoning Province. These semi-underground sites showed round or square symbols often found in semi-cave-style sites. From the ruins of the ancient city Jiaohe, it is possible to notice that on the original terrain of the platform, the highest place was selected to open a door on a wall. More space was then created by cutting along a vertical wall and digging into a cave.

The rammed earth method is to build walls by pressing layers of earth into form-works, which is one of the most widely used construction methods in Chinese earthen buildings (Wang, 1994). The earliest rammed earth wall in China was found in Chengtoushan ancient city in Feng county of Hunan Province 6,000 years ago. The shapes left behind from instruments used to press the earth are clearly visible. These instruments were often hammers obtained from local river stones. Many important buildings from the Shang Dynasty to the Tang Dynasty, including palaces, were built with rammed earth as a base and also to form the walls. For example, the Erlitou site in Henan, the Xianyang City in the Qin Dynasty, the Chang'an City and Luoyang City in the Han Dynasty are all built in rammed earth. Until the Qing Dynasty, important building foundations still used rammed earth method in China.

The method of stacked mud is to use a mixture of sand and lime, together with straw and water, and then pile them together to form walls. Building that was created using this method is called as straw mud buildings (Zhang et al., 2008). The first Chinese battlements from the early Zhou Dynasty at Qishan County, Shaanxi Province were built based on this method. This method was also widely used in the Jiaohe Old City, near Turpan in Xinjiang.

The adobe masonry method uses moulds to shape earth into bricks, which are then used for larger structures. The characteristic of adobe masonry is that the construction is more flexible and convenient, such as in the case of the beacons of the Han Dynasty in Dunhuang, Gansu Province. Adobe masonries were used in the same period as rammed earth buildings. The size of adobe bricks varies in different regions and periods. Straw can be added to earth in the realization of the bricks as in the case of the Jiangzhai site, Beishouling site in Shaanxi and Baiying site of Longshan culture in Tangyin, Henan province.

Raw earth masonries refers to the use of earth which is cut into moderate size blocks for masonry. This kind of masonry technology is relatively less used, and it can also be classified into adobe masonry class. (Wang, 2011)

CLASSIFICATIONS OF DECAY PHENOMENA IN EARTHEN SITES

Earthen sites play an important role in the study of Chinese history. At present, many cultural relics of earthen sites in China are severely damaged. Therefore, it is

particularly important to study the mechanism of deterioration in earthen sites (Wu, 2014).

1. Classification of decay phenomena

In response to the existing problems of Chinese earthen sites, scientific and detailed researches on the development of earthen sites have carried out by Chinese researchers; the deterioration of earthen sites can be due to natural reasons and to man-made destruction. It can be divided into 9 categories: spalling, erosion, fissure, gully, pulverization, biological reasons, microbial destruction, historical destruction and modern destruction (Zhang, 2006) (Sun et al., 2007).

1.1 Spalling

Spalling is a process in which the surface of an earthen site suffers pressure from external or internal forces, which results in a layer of crust peeling off in sheets or small blocks. The external or internal forces that lead to this phenomenology can be rain, wind, temperature or crack. The first two factors are very common in earthen sites in arid areas of northwest China.



Fig. 2 Spalling decay effect on a wall

1.2 Erosion

Erosion refers to the loss of earth to a certain depth, under the action of wind, rain, water and salt crystallization. It is a typical decay in the arid regions of northwest China.



Fig. 3 Erosion deterioration

1.3 Fissures

Fissures can develop due to different causes such as unloading fissures, structural joints, deformation fissures and manufacturing fissures. They often started the process of collapse.



Fig. 4 Fissure deterioration

1.4 Gully

Gully are formed through surface runoff generated by rainfall especially in the proximity of reliefs (Zhao et al., 2003). Fissure gullies and runoff gullies can be recognised.



Fig. 5 Gully deterioration

1.5 Pulverization

Pulverization is caused by periodic changes in the temperature and humidity, freezing and thawing or salt crystallizations.



Fig. 6 Pulverization decay effect

1.6 Biological decay

Biological damage is caused by the actions of animals or plants present around earthen sites.



Fig. 7 Biological damage caused by plant growth on earth sites

1.7 Microbial destruction

The decay due to microorganisms can cause serious damage to earthen sites. Some bacteria and molds can produce organic acids that directly decompose organic and inorganic matter in the earth causing powdering and flaking. In addition, some molds can secrete pigments which can adhere to the surface of cultural relics, and affect the appearance of earthen sites.



Fig. 8 Deterioration due to the growth of microorganisms: color variations, powdering and flaking

1.8 Historical destruction

Historical destruction refers to the destruction of earthen sites throughout history, although they should be protected as the original state of an earthen site.

1.9 Modern destruction

Modern destruction refers to the destruction of earthen sites caused by modern human activities. The forms and contents of modern destruction are complex and varied, such as industrial construction, agricultural farming, soil collection, houses building, roads building and water carriage system construction.



Fig. 9 An example of modern destruction, the Great Wall cut into two sections by a road

2. Research on decay mechanisms

Many factors can lead to damage of an earthen site. Common factors such as weathering, wind erosion, rain erosion and their associated decay phenomena are described in the following paragraphs (Zhao, 2008).

2.1 Weathering

Weathering is one of the most important causes of the decay in earthen sites. Weathering results in changes of the shape and colour of earthen sites. The factors affecting weathering of earthen sites include internal and external factors. Internal factors concern mainly the mineralogical composition and grain size distribution of the earthen material itself. The most important external factors lies in the kind of the outdoor environment. The weathering of earthen sites caused by environmental factors includes physical weathering, chemical weathering and biological weathering.

2.2 Wind erosion

In some areas where strong winds and sandstorms occur, the earthen artefacts have been eroded by wind and sand for thousands of years. The stronger the wind speed, the greater the capability of airflow to carry sand, and the greater the impact force on the earthen artefact, the higher is the erosion. Prolonged exposure to wind erosion can result in honeycomb-like surface textures, or surface layers that peel off like fish scales. A persistent enough wind can even penetrate a wall or a structure (Liu et al., 1985).

2.3 Rain erosion

The kind of earthen building (technology of construction, structural defects etc.) and the composition of the earthen material (grain size distribution, clay minerals composition) determine how much the earthen artefact can withstand exposure to water, especially in areas where rainfall intensity is high and concentrated. The damage of rain erosion is often quite serious. Rain erosion consists of raindrop erosion and runoff erosion. It is typical in the humid environments of southern China.

CONCLUSIONS

Earthen sites are scattered all over China and represent an important cultural heritage from a scientific, historical and landscape point of view. Due to heavy rainfall, most of the earthen sites in the south of China have disappeared. The most abundant interesting sites lie in the north, especially in the arid areas of northwest China. Nevertheless, some of them are in poor conditions of conservation. Recently, a lot of efforts have been done for the conservation of earthen sites in China. However, due to the complexity of the outdoor conservation and the rate at which earthen sites are deteriorating, the technology of earthen site protection cannot fully meet the needs of preserving the sites, and the protection work is still very difficult and arduous.

BIBLIOGRAPHICAL REFERENCES

- Chen X.N. (2014), *Monitoring and Simulation of Thermal Deterioration of Unsheltered Earthen Monuments*, Lanzhou, p. 56.
- Chen W.W., Lu H.M., et al. eds (2014), "Influence on Strength of Site Soils about Chlorine and Sulfate Salt in Dry Environment", in *Journal of Engineering Geology*, S1, pp. 333-338.
- Chen W.W., Lu H.M., et al. eds (2015), "Comparative study of the influence of chlorine and sulfate salt on grain size distribution and limit moisture content in site soils", in *Journal of Lanzhou University (Natural Science)*, 3, pp. 334-338.

- Cui K., Chen W.W. et al. eds (2007), *Research on geological-engineering characters of relic's soil in arid region of northwestern china*, Urumqi, pp. 367-371.
- Han L. (2009), <http://www.paper.edu.cn/releasepaper/content/200911-649>.
- Han L., Chen W.W., et al. eds (2010), "Influence of salt content and salt category on the elastic wave velocity of soil samples from ancient ruins in Shandan county", in *Journal of Lanzhou University (Natural Science)*, 46, pp.18-22.
- Jones C.I., Hammond G.P. (2008), "Embodied energy and carbon in construction materials", in *Energy*, 161(2), pp. 87-98.
- Liu L.X., Zhang Z.R., et al. eds (1985), "A Preliminary Study on the Weathering Mechanism and Protection of Ancient Cultural Relics", in *Relics and Museology*, 7, pp. 71-75.
- Mu J. (2016), "Exploring Renewing and Inheriting the Tradition of Earthen Construction", in *Architectural Journal*, 4, pp. 1-7.
- Ren F.F., Liang S.Y. et al. eds (2005), "The Protection of An Ancient City: Base on Thinking of the Soil Physical Characteristics", in *Journal of Gansu Sciences*, 4, pp. 117-120.
- Shen Y.X., Chen W.W., et al. eds (2011), "Testing Study on Influence of Salt Contents on Shear Strength of Ancient Relics Soil at Dry-wet Cycle", in *Northwestern Seismological Journal*, 1, pp. 227-230.
- Sun M.L., Li Z.X., et al. eds (2007), "Classification of Deteriorations Associated with Many Earthen Heritage Sites in Arid Areas of Northwest China", in *Journal of Engineering Geology*, 6, pp. 772-778,765.
- Sun M.L. (2010), *Preliminary study on the protection of earthen sites*, Beijing, pp. 3.
- Sun B., Zhou Z.H., et al. eds (2011), "Characteristics and prediction model of surface temperature for rammed earthen architecture ruins", in *Rock and Soil Mechanics*, 3, pp. 867-871.
- Wang X.D. (2008), "New progresses on key technologies for the conservation of Chinese earthen sites in arid environment", in *Dunhuang Research*, 6, pp. 6-12.
- Wang X.D. (2013), "Exploration of Conservation Philosophy for Earthen Sites in Humid Environments and an Outlook on Future Conservation Technology", in *Dunhuang Research*, 1, pp. 1-6.
- Wang W.Q. (1994), "Application of rammed earth technique", in *Standardization of Engineering Construction*, 5, pp. 46-47.
- Wang Y. (2011), "Analysis of the Forms and Causes of Damage to Earthen Sites", in *Science and Technology Information*, 25, p. 563.
- Wu X.J. (2014), *Study on Deterioration Evaluation Model of Earthen Sites*, Ganzhou, p.15.
- Zeng J.Q. (2017), "Research status and advance of the conservation on the ancient earthen sites based on the literature review", in *Western archaeology*, 13, pp. 297-308.
- Zhang G.H. (2006), *Research on Protection and Reinforcement of Earthen sites*, Xian, pp.9-10.
- Zhang H.Y., Zhao T.Y. et al. eds (2008), "The geotechnical construction methods

- in ancient China*", in *Dunhuang Research*, 5, pp. 81-90.
- Zhang H.Y., Liu P. et al. eds (2009), "*Generation and detachment of surface crust on ancient earthen architectures*", in *Rock and Soil Mechanics*, 7, pp. 1883-1891.
 - Zhang H.Y., Zhang X.C. et al. eds (2014), "*Research on thermal parameters of different earthen monument soils*", in *Rock and Soil Mechanics*, 1, pp. 57-62.
 - Zhao H.Y., Li Z.X., et al. eds (2003), "*Main Diseases and Their Causes of Earthen Ruins Arid Region of Northwest China*", in *Chinese Journal of Rock Mechanics and Engineering*, S2, pp. 2875-2880.
 - Zhao H.Y., Wang R., et al. eds (2007), *Tentative Research on the Consolidated Great Wall of Qin Dynasty at the Warring States*, Wuhan, pp. 79-84.
 - Zhao M.X. (2008), "*On reinforcement and conservation measures of earthen archaeological site*", in *Shanxi Architecture*, 8, pp. 144-145.
 - Zheng L., Zhou Z.H., et al. eds (2008), "*Monitoring the temperature changes of earthen architecture walls*", in *Journal of Lanzhou University(Natural Sciences)*, S1, pp. 58-60.
 - Zheng L. (2009), *Study of Simulation Experiment on Hydrothermal Change in the Artificially Wall of Earthen Architecture Sites*, Lanzhou, p. 23.



PART 3

**CONSERVATION OF EARTHEN ARCHITECTURE
SITES IN ITALY AND CHINA**



EARTH MATERIALS: CHARACTERIZATION AND TRADITIONAL/INNOVATIVE TECHNIQUES OF CONSERVATION

FABIO FRATINI, LOREDANA LUVIDI, SILVIA RESCIC

National Research Council - CNR, Institute of Heritage Science - ISPC, Italy

Keywords: Earth materials, characterization, conservation, earthen architecture, on site treatment

INTRODUCTION

The word “earth” commonly designates what must be correctly called soil, namely the surface layer that covers the Earth’s crust and is formed through weathering of the rocky substrate due to rain, thermal cycles, salt crystallisation, growth of plant, the metabolism of microorganisms, etc. These agents through chemical, physical and biological actions determine the transformation of the rock in another material, the soil, which has compositional, physical and mechanical characteristics completely different from the original rock material.

A solid portion (mineral component and organic component), a liquid portion and a gaseous portion compose the soil. Along its formation, it differentiates in a series of layers called horizons:

- the superficial horizon that contains 5%-10% of organic substance;
- an underlying eluviation horizon made of residual minerals (quartz), clay minerals and insoluble organic substances (humic acids) in which the meteoric water leaches the alkaline and alkaline earth elements towards the underlying illuviation horizon;
- the underlying illuviation horizon where the inorganic fraction prevails strongly with respect to the organic fraction and it is enriched of alkaline and alkaline earth metals.

In the following, the characteristics that mostly influence the behaviour of the “earth” in the masonries will be considered, namely the composition of the mineral component and the physico-mechanical characteristics (Fratini, 2011).

THE MINERALOGICAL CHARACTERISTICS OF AN EARTH

The mineral component of an earth consists of a fine-grained fraction mainly composed of *clay minerals* belonging to the Phyllosilicates class (which dimension is below $4\ \mu\text{m}$) and a coarse-grained fraction (silt, sand and gravel fractions) composed of quartz, feldspars, carbonate, iron hydroxides and rock fragments (Fig. 1).



Fig. 1 Particular of an earth, it is possible to recognize the different grain fraction and the organic component

The clay fraction is very important in the earth, because it is the binder that allows the realization of earthen artefacts. It is also true that the behaviour of clay minerals affects the durability of the earthen building and in particular because these minerals are strongly influenced by the interaction with water.

Genetically the clay minerals form through chemical physical alteration of feldspars in exogenous environment or through hydrothermal phenomena with loss of Na, K, Ca, Mg and consequent enrichment in Al and Si. From the chemical point of view they can be classified as silico-aluminate hydrates containing Mg^{2+} , Fe^{3+} , Na^+ , K^+ .

The word *Phyllosilicates* comes from *filos*, leaf in Greek, with clear reference to their most common habit which is tabular. The crystal lattice is characterised by the various combination of *tetrahedral layers* (constituted by Si-O tetrahedra) and *octahedral layers* (gibbsitic and brucitic layers). These layers, depending on their

composition, can establish more or less strong bonds among them and give rise to particles of different granulometry. This results in a very different mechanical behaviour. For example, kaolinite has a typical particle size of about 1 μm , with rather strong bonds and therefore it gives rise to a stable clay, less sensitive to the action of water. On the other hand, smectite gives rise to particles of a few nanometers (1 nm = 10^{-3} μm), and has weak bonds between the layers that in presence of water tend to break (swelling behaviour). Water can interact with the clay minerals because the octahedral and tetrahedral layers despite being generally neutral, have a positive charge in the interior and negative charge on the external surface. This feature leads to establishing very strong bonds with water molecules which, being dipolar, are electrically attracted to the surface of the clay particles. The water that is immediately in contact with the particles therefore becomes an integral part of their structure and is defined as "adsorbed water".

Moving away from the surface of the particles, the bonds gradually become weaker until the water takes on the characteristics of "free water" or "interstitial water". Even taking into account the presence of adsorbed water, the clay particles are negatively charged on the surface of the flakes and positively charged on the edges (neutral environment). Therefore, they tend to manifest repulsive forces, to which are added the Van der Waals forces, attractive on the long distance and repulsive at short distance.

This means that if the clay particles are surrounded by a fluid with a high concentration of positive ions (for example, in the marine environment), the superficial negative charges will tend to neutralize and therefore the repulsion effect will be lower and the particles will tend to aggregate with consequent sedimentation. On the contrary, in an environment that is poor in positive ions (for example in freshwater), repulsion forces tend to prevail and the clay particles will tend to remain in suspension.

Therefore, in earth rich in clay, the particles may also not be in direct contact with each other while retaining the material characteristics of continuity, favouring the flow of interstitial water and consequently making this type of earth susceptible to swelling.

From the mechanical point of view, earths are considered as pseudo-coherent rocks and can be divided into the following two categories:

- *fat earths*, consisting of a high % of clay minerals, retain a large amount of water and lose it slowly by evaporation, have high plasticity, strong cohesion of the dried product but at the same time cracking in the shrinkage phase;
- *lean earths*, consisting of a high % of coarse fraction, retain a low amount of water and lose it quickly, have low plasticity, low shrinkage in drying, low cohesion of the dried product.

The type of porosity that develops during shrinkage is different for the two kinds of earths: fat earths display mainly a cracking macroporosity while lean earths, where the coarse fraction acts as framework contrasting shrinkage, display mainly an intergranular porosity.

The characteristics of the dried product depends also on the kind of clay minerals: the presence of swelling clay minerals (smectite, vermiculite) can increase the shrinkage with strong cracking and worsening of the mechanical characteristics. The presence of non-fibrous dispersed organic materials can increase the plasticity and could cause cracking problems. The regularity during drying allows developing balanced cohesive forces that hinder the formation of cracks. Therefore, in order to have good mechanical characteristics in the dried product, we need a quantity of clay minerals such as to produce a good cohesion (i.e. a low intergranular porosity) but also to avoid the development of cracking during shrinkage.

THE CHARACTERIZATION OF EARTH MATERIALS

The study of the *mineralogical composition* is carried out by X-ray diffraction, an analytical method that allows recognition of phases with crystalline structure present in a material.

In particular, the clay minerals are studied by analysing the granulometric fraction below 4 μm (obtained by separation from the bulk through sedimentation) on oriented powder samples meaning that the clay minerals are oriented according to the lattice baseline planes. This preparation is needed because these minerals are characterized by different distances between the lattice baseline planes and the orientation makes it possible to better investigate this distance thanks to special heat treatments and absorption of substances (e.g. ethylene glycol).

The determination of *calcium carbonate content* is performed through the method of calcimetry.

The *organic matter content* can be determined gravimetrically by attack with hydrogen peroxide.

The *content of soluble salts* can be determined according to the following methods:

- gravimetric method (the amount of all ionic species is obtained);
- ion chromatography (the amount of individual ionic species is obtained)

The *grain size distribution* can be determined through different methods. A common grain size classification is according to the Wentworth scale: gravel (diameter > 2 mm), coarse sand (0.2 - 2 mm), fine sand (0.02 - 0.2 mm), silt (0.002 - 0.02 mm) and clay (< 0.002 mm).

Sieving methods, operating at dry or wet conditions, are used for the study of the coarser fraction (gravel and sand).

In order to study the fine fraction (silt and clay) (< 0.075 mm according to ASTM or < 0.063 mm according to BS and AFNOR standards), the *Sedimentation method* can be used which is based on the separation of the sample suspended in a liquid placed in a cylinder where the particles tend to settle at different speeds due to gravity according to Stokes Law. Different measurement methods can be used:

- *pipette method*: it consists in sampling the material in suspension at a depth s and time t ;
- *densimeter method* with hydrostatic balance: the grain size distribution is determined through the measurement of the progressive reduction of the density of an earth suspension, caused by the sedimentation of the particles;
- *optical methods*: are based on the principle that particles diffract a light ray according to an angle that is higher the smaller the particles.

Study of plasticity: Atterberg limits

“Earth” may occur in one of the following four states, depending on the content of water: liquid, plastic, semi-solid, solid. In fact, for low values of water content, the forces among the clay particles prevail and the material has a consistent aspect (solid or semi-solid depending on the water content). With increasing water content, the pore volume increases, the forces among particles becomes negligible and the material loses its formability assuming the characteristics of a very viscous fluid.

The characteristics of plasticity are measured in the laboratory by tests for determining the content of water to which an earth passes from a liquid to a plastic state and solid state. These are the *limits of consistency or Atterberg limits*:

- *liquid limit* (WL): minimum water content for which the earth runs due to a little pressure (on the order of 2-3 kPa) and behaves like a viscous fluid;
- *plastic limit* (WP): minimum water content for which the earth may be deformed plastically without splintering;
- *shrinkage limit* (WS): water content below which the earth does not undergo more reduction in volume when it is dried.

The *activity of the clay fraction* is determined through the *method of methylene blue*. The principle consists in quantifying the capability of ionic absorption of an earth by measuring the amount of methylene blue required to cover the total area of the particles constituting the earth.

CONSERVATION PROBLEMS OF EARTHEN ARCHITECTURE

Earth architecture is particularly subject to decay processes. For this reason it requires *constant maintenance* not only from the point of view of conservation, but to guarantee its real functionality, a prerequisite to make sure that this architecture continues to be inhabited and built (Figg. 2, 3). In particular, the factors of decay are *internal factors*, due to structural defects and *external factors*, such as the action of water and the type of use (Fratini, 2014).

The earth material is particularly sensitive to the action of water because water tends to make earth plastic again with consequent loss of the mechanical characteristics of resistance and rigidity. The water acts both as an erosive agent (rain) and as

capillary rising damp with consequent disaggregation phenomena (Fig. 4). The decay phenomena can be grouped into the following categories:

- superficial decay of physical and biological nature;
- humidity patches; fracturing, swelling and exfoliation of plasters; biological patinas;
- loss of material due to erosion and fall of elements.

This last phenomenon develops in areas that have lost cohesion due to the action of water. They can influence the stability of the structures in case the loss of material affects important building elements. These phenomena are mainly located at the base of the walls (due to bad drainage that determines capillary rise and disintegration of the masonry) and at the corners (exposure to rain and wind).



Fig. 2 Syrian corbelled dome house, well maintained



Fig. 3 Syrian corbelled dome house, lack of maintenance



Fig. 4 Rain erosion of an adobe masonry in Piedmont (Italy) due to lack of maintenance of the roof

PREVENTIVE CONSERVATION OF EARTHEN ARCHITECTURE

The above mentioned factors of decay are usually related. Therefore, in order to develop an adequate intervention, non-damaging and preventive with regard to the possible establishment of new decay phenomena, it is important to understand which is the actual cause of the processes and not just intervening on the single phenomenology. It has been said that the factors of decay are essentially due to action of water and structural problems. Therefore, a preventive conservation will have to act in these two directions.

With regard to water, all the solutions designed to protect buildings from the rain, to avoid capillary rise and infiltrations must be taken through the following interventions:

- more resistant plaster coatings, possibly stabilized with suitable products (e.g. lime) and reinforced with non-rigid vegetable fibres that prevent shrinkage cracking (Fig. 5, 6). Furthermore, whitewashing would be desirable (normally limited only to the lower part of the constructions) to make them a little more resistant to the washing action of the rain (Fig. 7);
- improvement of the run-off water drainage system, in order to avoid stagnation and concentrated flow on the walls (Fig. 8, 9);
- improvement of the drainage system on the ground in order to avoid erosion at the base of the walls and to avoid capillary rise.

With regard to structural problems, it is necessary to implement strategies that limit the consequences of the poor connection among the walls and with the roof and foundations (Fratini, 2012).



Fig. 5 Accurate maintenance of houses in the village of Ait Ben Haddou (Morocco)



Fig. 6 Earthen plaster added with vegetable fibers to avoid shrinkage fractures (Morocco)



Fig. 7 Whitewashing in a Syrian corbelled dome village



Fig. 8 Improvement of the water run-off to avoid concentrated flow on the walls in a Syrian corbelled dome house



Fig. 9 Protection of the ridge of the walls to avoid water infiltration (Morocco)

TRADITIONAL/INNOVATIVE TECHNIQUES OF CONSERVATION

Earthen plasters for the protection of surfaces

The term plaster generally indicates the superficial layer that covers the masonries in order to protect them, ensuring adequate waterproofing and a regular finishing (Figg 10, 11). Specifically, with regard to earthen plasters, their use has been documented since ancient times; in the Neolithic period, to give greater resistance over time to the artefacts, a layer of mud was applied on a wooden trellis forming the wall of the huts (similar to the present building technique called wattle and doubt). Later, other and more refined types of plaster, such as mixes of clay, sand and gypsum, evolved from the Minoan era, until reaching, at the beginning of the Roman Empire, the highest expression. In the Middle Ages there was a stop in the progress of the technique while in the Renaissance, thanks to the flourishing of the treatises, the knowledge and techniques of earth use were rediscovered. Afterwards, during the XIX century, with the increasing use of the modern hydraulic binders, new types and applications of plaster were developed causing the progressive abandon of the earthen plasters. Today, however, the new bio-architecture currents are trying to recover these artefacts. The properties of an earthen plaster, suitably stabilized applied on earthen masonries have many positive aspects with respect to those made of lime or cement:

- mechanical and chemical compatibility with the earthen support;
- good permeability to water vapour;
- increasing the thermal and acoustic insulation.

In addition the earthen plasters are reversible, recyclable, non-toxic, easily removable, non-polluting, easily available and without energy consumption.

The additives/stabilizers used to improve the durability of the earthen plasters and in general the earthen masonries are distinguished in inorganic and organic (natural or synthetic), sometimes mixed. Among the inorganic additives, there are lime, gypsum, Portland Cement, or other pozzolanic materials (rice husk ash, ground granulated blast furnace slag) (Eires, 2015; Choobbasti, 2010; Rescic, 2021).

The stabilizing action of cement (improvement of compressive strength, resistance to erosion, to rain and abrasion) develops through the formation of hydraulic compounds (CSH, CAH). These cement compounds do not bind with all of the earth particles, but help to form a stable matrix throughout. Lime is one of the oldest and most widely used stabilizers. Several authors have studied the interaction between lime and earth and it has been determined that the addition of lime improves strength, stiffness, plasticity/workability of raw earth. The lime-earth reaction can be described by three phenomena: 1) cation exchange; 2) pozzolanic reaction with formation of hydraulic compounds; 3) carbonation (Ciancio, 2014). The lime offers the advantage of carrying out its action by maintaining the peculiar characteristics of the pure earthen plaster (breathability in the first place) (Mattone, 2016; Falchi, 2016). Gypsum is an

additive widely used for the stabilization of the earthen plasters thanks to its compatibility, breathability, elasticity and for its economic convenience and eco-sustainability (Mattone, 2017). Gypsum is easily available and low energy consumption is needed for its production process. Furthermore, during the setting phase, it increases in volume contrasting shrinkage during the drying phase thus preventing the formation of cracks. Chemical stabilization (alkaline activation or geopolymerisation) was recently introduced for the in situ consolidation of the Alhambra earthen walls (Elert, 2008). The process of geopolymerization can be simplified in two main phases which interact with each other during the process: 1) the alkaline solution attacks the crystal lattice of the clay minerals with weaker structure (the expandable lattice clay minerals such as smectite and illite-smectite) with subsequent release of silicon and aluminium in solution; 2) polymerization by condensation of the species released and formation of silico-aluminates compounds similar to those of cement (Hardjito, 2010; Mubarak, 2011). The results of this process are time dependent, therefore a long curing time is essential for a complete reaction and compounds formation.

Organic compounds (e.g. bitumen, fibres, mucilage, gums, resin, oils and fats, tannins, etc.) (Van Damme 2017; Kita, 2013; Vissac, 2017; Gomes, 2012; Laborel-Préneron, 2016) traditionally used to improve the performances of mortars and blocks are numerous and are often mixed with the inorganic materials (e.g. lime) (Rodriguez-Navarro, 2017). Bitumen is added in the form of an emulsion and forms a thin film which coats the clay particles during drying. The main effect of adding bitumen is to improve cohesion and water resistance. Fibres are widely used in earthen building (Fig. 6). The fibres act to increase the tensile strength, reduce density, accelerate drying and reduce cracking by dispersing stresses. The most common fibres used include straw, for example from wheat, rice or barley. The chaffs or husks of these crops can also be used. Other suitable vegetable fibres include hay, hemp, millet, sisal, filao needles, and elephant grass. The influence of biopolymers addition (i.e. mucilages, gums, resin, oils and fats, tannins, etc.) in earth materials result in rheological effects developed in clay particles of soil. The main effect verified is related to the change of the electrostatic charge of the clay particles. This causes dispersion and after attraction. The use of oils or fats has been the most used waterproof process in earthen buildings. In fact if oils or fats are added in basic environments (earth based plasters with lime) their triacylglycerol's content, when hydrated, results in insoluble calcium salts of fatty acids. These salts are hydrophobic and connect well with the calcium of lime and provide water repellency (Čechová, 2009). In some Latin American territories and, in particular, in Mexico, earthen mixtures stabilization was traditionally made through the addition of vegetable fibres such as straw and mucilage of succulent plants. The use of the mucilage of Nopal (*Opuntia Ficus Indica*) is particularly widespread. This product was commonly used since the pre-Hispanic era in earthen buildings and, according to scientific studies conducted so far, it would offer a solution to the problem deriving from the scarce availability of water, necessary for the realization of architectural artefacts, in many Central American territories.

More recently, synthetic compounds like PVC, polyvinyl acetate, acrylics, sodium silicate and many others have also been introduced in various amounts to stabilize earth-based materials.



Fig. 10 Ongoing works to protect with an earthen plaster the walls of a village in Morocco



Fig. 11 The earthen plastered city walls of Marrakech

Products for on site treatments

Particularly valuable earthen masonries in which the application of an earthen plaster is not admissible for aesthetic reasons, requires consolidation/protection of the earth material itself with appropriate products.

The first experimentations were concentrated in the identification of consolidants and water-repellent products, based on silicates and epoxy resins. However, the application of these products gave rise to many problems; the interventions were completely irreversible, the cost was high, some products were polluting/toxic and in general they did not lead to definitive and effective solutions. Therefore, over the years, the use of these products has decreased. Research focused first on other products like sodium silicate, colourless silicon-based paints or polyurethane-based inorganic products. Nevertheless also these products showed to be ineffective or with disadvantages, such as the lack of vapour permeability.

At present the researches are concentrated around substances of natural origin obtained mainly from plants such as banana leaves, coconut oil, carob, prickly pear sap, aloe vera, cactus mucilage, etc. (Mattone, 2010). Only some of these materials are tested in the laboratory and only occasionally, on the private initiative of a few scholars, are thoroughly investigated and scientifically verified.

BIBLIOGRAPHICAL REFERENCES

- Čechová, E. (2009). *The effect of linseed oil on the properties of lime-based restoration mortars*. Ph. D., University of Bologna.
- Choobbasti A.J., Ghodrat H., Vahdatirad M.J., Firouzian S., Barari A., Torabi M., Bagherian A. (2010). *Influence of using rice husk ash in soil stabilization method with lime*. *Front. Earth Sci. China*, 4(4): pp. 471-480.
- Ciancio D., Beckett C.T.S., Carraro J.A.H. (2014). *Optimum lime content identification for lime-stabilised rammed earth*. *Construction and Building Materials*, 53: pp. 59-65.
- Eires R., Camões, A., & Jalali, S. (2015). *Ancient Materials and Techniques to Improve the Earthen Building Durability*. *Key Engineering Materials*, 634: pp. 357-366.
- Elert K., Sebastián E, Valverde I., Rodriguez-Navarro C. (2008). *Alkaline treatment of clay minerals from the Alhambra Formation: Implications for the conservation of earthen architecture*. *Applied Clay Science* 39(3-4): pp. 122-132.
- Falchi L., Fratini F., Rescic S., Pirolandi L., Ricci G., Zendri E. (2016). *From the historical sugar refinery of Chichaoua (Morocco) to the lab: a reverse engineering experimentation on the hydration of earthen materials stabilized with lime*. *J. Mater. Environ. Sci.*, 7 (10): pp. 35-35.
- Fratini F. (2011). *Earth and earth conglomerates*. In "Earth/Lands: Earthen Architecture of Southern Italy", Collana Sentieri Saperi e Progetti, ETS Editions, Pisa (Italy): pp. 99-105 ISBN: 9788846721464.

- Fratini F., Rovero L., Tonietti U. (2012). *Earthen domes in the Aleppo region (Syria): materials and building techniques*. In Congress Proceedings “Domes in the World”, Florence, March pp. 19-23, 2012, Tampone, Corazzi, Mandelli Scientific Editors, Nardini Editore Firenze (Italy) ISBN:9788840442112.
- Fratini F., Rescic S., Riminesi C., Mattone M., Rovero L., Tonietti U. (2014). *The vernacular earthen architecture near Turin (Piedmont, Italy)*. In “ Earthen Architecture: Past, Present and Future – Mileto, Vegas, García Soriano & Cristini (Eds), pp. 145-150 © 2015 Taylor & Francis Group, London. ISBN 978-1-138-02711-4.
- Gomes M.I., Goncalves T.D., Faria P. (2012). *Earth-based repair mortars: experimental analysis with different binders and natural fibers*. In RESTAPIA 2012 – International Conference on Rammed Earth Conservation (A), Universitat Politècnica de València, Valencia, 21-23 June 2012, Mileto, Vegas & Cristini (eds.), Taylor & Francis Group, London, pp. 661-668.
- Hardjito D., Fung S.S. (2010). *Fly Ash-Based Geopolymer Mortar Incorporating Bottom Ash*. *Modern Applied Science*, 4 (1) pp. 44-52.
- Kita Y. (2013). *The functions of vegetable mucilage in lime and earth mortars – A review*. In HMC2013 - 3rd Historic Mortars Conference , Glasgow (2013) CD-ROM.
- Laborel-Préneron A., Aubert J.E., Magniont C., Tribout C., Bertron A. (2016). *Plant aggregates and fibers in earth construction materials: A review*. *Construction and Building Materials*, 111: pp. 719-734.
- Mattone M. (2010). *Prevenire il degrado: la protezione delle costruzioni in terra cruda*. In proceedings of the congress “Scienza e Beni Culturali: pensare la prevenzione, manufatti, usi, ambienti” Bressanone July 13-16, 2010: pp. 141-149.
- Mattone M., Ibnoussina M, Rescic S., Fratini F., Magrini D., Mecchi A.M., Nocairi M. (2016) *Stabilization of earthen plasters: Exchange of knowledge and experiences between Italy and Morocco*. *J. Mater. Environ. Sci.* 7(10): pp. 3647-3655.
- Mattone M., Rescic S., Fratini F. & Manganelli Del Fà R. (2017). *Experimentation of Earth-Gypsum Plasters for the Conservation of Earthen Constructions*. *International Journal of Architectural Heritage*, DOI: 10.1080/15583058.2017.1290850.
- Mubarak Y.A., Al-Swalkah A.I., Sweis F.K. (2011). *The Effect of Alkaline Additives on the Operating Conditions of Kaolinitic Polymerization*. *Jordan Journal of Mechanical and Industrial Engineering*, 5(5): pp. 389-401.
- Rescic S., Mattone M., Fratini F., Luvidi L. (2021). *Earthen Plasters Stabilized through Sustainable Additives: An Experimental Campaign*. *Sustainability* 13 (3), 1090. <http://doi.org/10.3390/su13031090>.
- Rodriguez-Navarro C., Ruiz-Agudo E., Burgos-Cara A., Elert K., Hansen E.F. (2017). *Crystallization and Colloidal Stabilization of Ca(OH)² in the Presence of Nopal Juice (Opuntia ficus indica): Implications in Architectural Heritage Conservation*. *Langmuir* 33, pp. 10936-10950.
- Van Damme H., Houben H. (2017). *Earth concrete. Stabilization revisited*. *Cement and Concrete Research* <https://doi.org/10.1016/j.cemconres.2017.02.035>.
- Vissac A., Bourgès A., Gandreau D., Anger R., Fontaine L. 2017. *Argiles & Biopolymères les stabilisants naturels pour la construction en terre*. CRAterre éditions, Villefontaine Cedex (France). ISBN: 978-2-906901-93-3.



EARTHEN CONSTRUCTION AND SEISMIC ACTION: NEW PERSPECTIVES BETWEEN TRADITION AND INNOVATION

LUISA ROVERO, GIULIA MISSERI, ARASH BOOSTANI, UGO TONIETTI

Department of Architecture, University of Florence – Italy

Keywords: Earthen construction, Earthquake, Timber retrofitting, Glass Textile Reinforced Mortar (TRM), Three-Point Bending Test

INTRODUCTION

The earth material, in all possible variants (adobe, rammed earth, cob, etc.), has a lot of potentiality because it uses a low-cost and non-polluting environmental resource, the soil, and allows the construction of sustainable buildings, which naturally guarantee environmental well-being also in climates with high temperatures (Minke, 2006; Pacheco-Torgal, 2012).

History has given us earthen buildings of great architectural value, also protected by UNESCO, and about 30% of world population (50% of developing countries population) lives in building made with earth material (Houben, 1994). Therefore, the interest in the earthen buildings does not only concern the preservation and enhancement of an architectural heritage of seductive beauty (Boostani, 2018; Baglioni, Fratini, 2016; Baglioni, Rovero, 2016; Rovero, 2015; Rovero, 2012; Gamrani, 2012), but it is also connected to social and environmental issues because it can represent an alternative living resource in a sustainable perspective.

The main limit of the earth material is related to the low mechanical properties (Briccoli Bati, 2011; Fratini, 2011; Liberotti, 2016). In particular, as regards the resistance to compression forces, earthen constructions can guarantee good levels of safety thanks to the use of walls with high thicknesses and therefore considerable masses. However, these high thicknesses combined with around zero tensile strength make the earthen constructions very vulnerable to the actions produced by earthquakes, which inevitably induce traction in the walls. The result is that the orthogonal walls separate, the floors lose supports and collapse, and the walls overturn. In

the literature, there are many works that describe the effects on earth constructions produced by earthquakes and the modeling suitable for capturing the mechanical behavior of earthen buildings (Tolles, 2003; Cancino, 2010; D'Ayala, 2012; Lourenço, Pereira 2018; Lourenço, Ciocci, 2018; Briceño 2018; Misseri, 2020).

The goal of this work is to investigate the seismic safety conditions of earthen buildings, exploiting a simplified case study: one-storey building, consisting of a single cell made of adobe walls reinforced with two different anti-seismic retrofits. In particular, a timber system and a fibreglass reinforced earthen plaster are considered as retrofits and the out-of-plane capacity of the reinforced adobe walls is evaluated through the linear kinematic analysis, varying the dimensions of the walls.

CASE STUDY

A set of simplified adobe buildings were chosen as reference models on which evaluating variations of the effect induced by seismic actions on earthen architectures. A one-floor squared cell, centre-line side equal to $l = 4$ m, is considered and variations of geometry consider height and thickness of walls (Fig.1a). The limits set are within the ranges recommended by the New Mexico State Building Code (NMAC, 2010). Table 1 reports the variations considered for walls.

Table 1 – Values of thickness (t), height (H) and slenderness ratio (t/H) for the reference models

t/H	t	H
[-]	[m]	[m]
0.0923	0.30	3.25
0.0972	0.35	3.60
0.1110	0.40	3.60
0.1250	0.45	3.60
0.1667	0.60	3.60

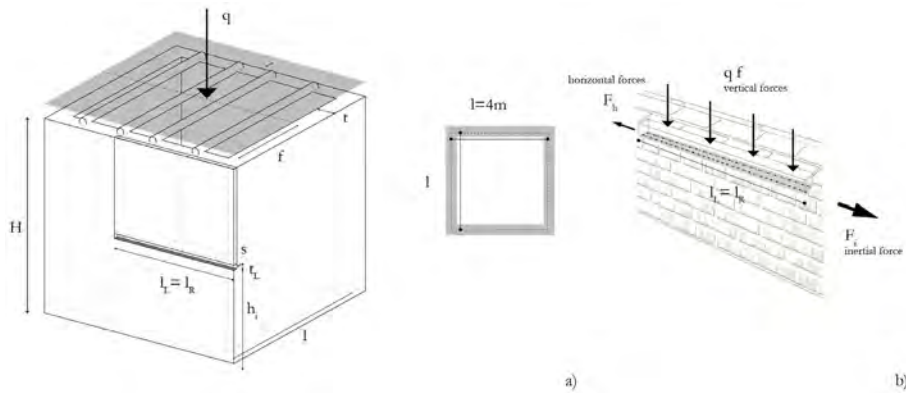

Fig. 1 a) Reference model of the masonry box: H , l and t are respectively height, centre-line length and thickness of the masonry box (thickness and heights considered are reported in Table 1); q , f and t_2 are respectively: the surface load of the slab, the influence length of beams and the support depth of beams. b) Indication of the timber-masonry interface, in grey, where horizontal restraint forces, F_h , (in the opposed direction of inertial forces, F_i) that can develop thanks to vertical forces, $q \cdot f \cdot l$, inducing frictional resistive mechanisms

ANALYSIS METHOD

Assuming good quality of adobe masonry and low quality of connections between walls makes possible to analyse the effect of the out-of-plane overturning of an entire wall panel, such a local response mechanism often occurs during earthquakes inducing deep cracks and failures. This kind of response is frequent in masonry buildings because a low level of energy, i.e. acceleration, is sufficient to induce the activation of motion and eventually the complete collapse. To investigate this typical behaviour of masonry structures, i.e. local response through activation of out-of-plane overturning mechanisms, limit analysis (Heyman, 1966, Livesley, 1978 Koocharian, 1952) represents an adequate and acknowledged investigation tool; in fact, conservative estimations with low computational costs can be made.

For the present case study, the external forces acting on the considered wall are those connected to inertial mass: the self-weight of the wall, P , and the horizontal force caused by the acceleration of the wall mass, proportional to self-weight by means of a coefficient, λ_w , as represented in Fig. 2a. The value of the load coefficient for the simple overturning of a wall without any superimposed force has to do with geometrical proportions only:

$$\lambda_w = \frac{t}{H} \quad (1)$$

where t and H are respectively the thickness and the height of the wall.

To measure the actual mechanical capacity of adobe, it can be assumed that the vertical compressive stress at the foot of the wall shows a linear distribution that cannot exceed in intensity the value of the compressive strength of adobe, see Fig. 2b. Therefore, the resultant of reacting forces, and thus the position of the plastic hinge, moves inward and the vertical horizontal displacement of P would become:

$$\eta_y^* = \varphi \cdot t^* = \varphi \cdot (t/2 - b/3) \quad (2)$$

$$\text{where } b = 2 \frac{P}{f_{CD} l}$$

f_{CD} , is the compressive design strength of adobe masonry, i.e. characteristic compressive strength reduced by appropriate safety coefficients (see below), and l is the centre-line length of the adobe wall, assumed equal to 4 m.

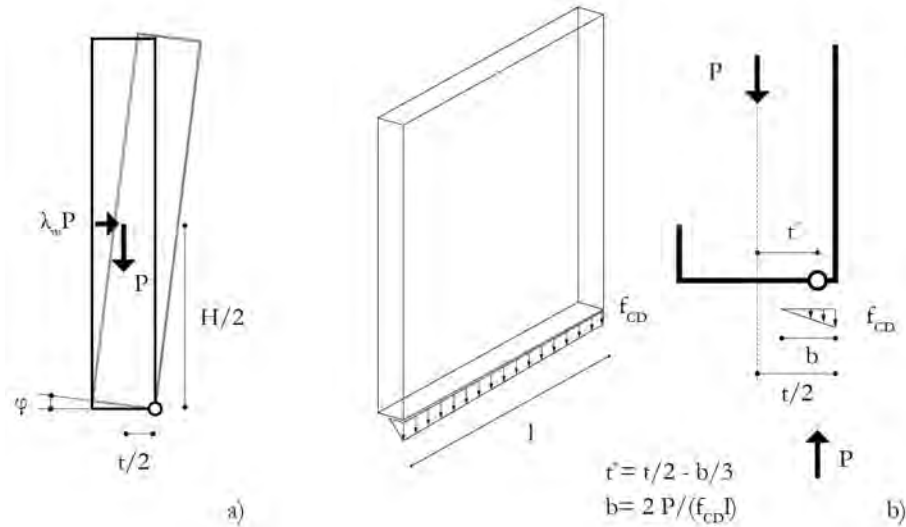

Fig. 2 a) Overturning of rigid wall of thickness t and height H subjected to self-weight (P) and inertial load ($\lambda_w P$). b) Overturning of a wall assuming limited compressive strength, f_{CD} , which makes the plastic hinge moving inwardly of $b/3$

In the Fig. 3a is represented the value of the load coefficient, λ_w , obtained through Equation (2) for the overturning rigid wall (RW series), superposed to the series RW- f_{CD} of load coefficients, in which it was assumed a limited compressive strength of adobe,

$$f_{CD} = \frac{f_m}{\gamma_m F_C} = 0.56 \text{ MPa,}$$

where f_m is the characteristic compressive strength, $\gamma_m = 2$ is a partial safety coefficient for masonry and $F_c = 1.35$ is a safety index, named confidence factor in the Italian National Standards, (NTC 2018), that takes into account the level of knowledge about the construction (e.g. types and extension of direct and indirect surveys, *in situ* and laboratory tests). It can be noted that the higher is the load coefficient the stronger will be the intensity of the earthquake necessary to trigger an overturning mechanism.

Fig. 3a shows, in addition to the results of the load coefficient, γ_w , the linear bisector of the quadrant, with the aim of highlighting that the RW sequence follows a linear law equal to the slenderness of the wall. Fig. 3a also shows the Peak Ground Acceleration levels of three sites in Italy characterised by medium and high hazards. The comparison of with real PGAs shows that only stockier walls would not overturn if subjected to a medium level acceleration.

Buildings also bear the weights of slabs or ceilings; beams of the slab can lay orthogonally or parallel to the wall under investigation, anyway, values of the load coefficient would tend to lower.

When multiple loads act on the wall, the value of the load factor must be transformed into the acceleration necessary to activate a mechanism:

$$\alpha_{\dot{0}} = \frac{\lambda \cdot \sum P_i \cdot \sum P_i \delta_{x,i}^2}{\sum (P_i \cdot \delta_{x,i}^2)^2} \quad (3)$$

where, P_i is the i -th load acting on the wall and $\delta_{x,i}$ is the x -(horizontal) virtual displacement of the i -th load.

For a configuration of the slab on the 4 x 4 m masonry cell where main beams rest on the overturning wall, Fig. 3b shows the values of the activation acceleration of the mechanisms, RW-P2, compared to those of the overturning rigid wall, RW. Looking at Fig. 3b it can be noted that the superimposed slab force P2 affects slender walls more than stockier. Owing to superimposed loads, the value of the activation acceleration decreases, with respect to that of the simple rigid wall, by 5.4% and 0.6% respectively for the slenderest and stockiest profiles.

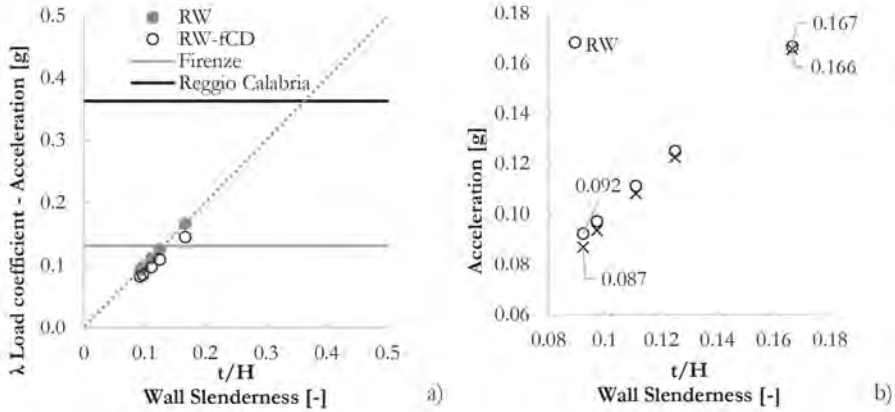

Fig. 3 a) Load coefficient values, coincident with the activation acceleration, for the overturning rigid wall (RW) and assuming a limited compressive strength $f_{cd}=0.56\text{MPa}$ (RW- f_{cd}) superposed to the expected peak ground accelerations in Firenze and Reggio Calabria (Italy). b) Activation acceleration values of an overturning rigid wall (RW) and for the same wall bearing an over load P2=28KN (RW-P2)

RETROFITS

Two different anti-seismic systems have been considered. The first set of retrofit systems has ancient roots and is based on the use of wood. In fact traditional construction techniques of seismic risk areas (Balkans, Near East, Maghreb, etc.) have often identified this material appropriate to supply tensile capacity to in the masonry constructions (Abdessemed-Foufa, 2010; Vissilia, 2010) as showed in Fig. 4. Among these systems, there are continuous *ring beams* or *bond beams*, which are installed at each slab level with the main objective of transferring homogeneously loads to the walls. Timber elements, placed along the top of the walls and on both sides, constitute the main components of bond beams. Then transverse and littler wood elements provide a link between the former two, constituting a sort of "ladder", as recommended, for example, in the Indian and Peruvian anti-seismic building codes and guidelines (International Association for Earthquake Engineering 2004; Centro Nacional de Conservacion and Restauration 2010). In addition to *bond beams*, there are *corner keys* or *chains*, which are isolated timber elements, placed at different heights, and are provided with a restraint placed orthogonally to the main façade with the aim of tying and deferring the overturning. The reinforcement device is identified by its geometrical dimensions: l_L , s and t_L and by its height, h_i , Fig 1a. Thanks to bond beams and corner keys, horizontal frictional response mechanisms develop at masonry-timber interfaces due to the ceiling overload and the self-weights of wall portions insisting on timber, see Fig. 1b.

In the context of the linear kinematic analysis, horizontal restraining forces due to the weight of slabs, F_{hs} , and masonry, F_{hm} , can be evaluated, according to Gilbert (2006), through the following expressions:

$$F_{hs} = 2 q f l_R \mu \quad (4)$$

$$F_{hm} = \gamma \cdot 2s \cdot l_L \cdot (H - h_i - t_L) \mu \quad (5)$$

where, q and f are respectively the surface load and the influence length of the slab insisting on the wall orthogonal to the one on the verge of instability; l_R is the length of the restraining device (whole depth of the masonry cell in case of a bond beam) and μ is the wood-earth friction coefficient. In Equation (5), γ is the specific weight of masonry, l_L is the length of the masonry portion insisting on the restraining device, s and t_L are respectively the depth and the thickness of the restraining device. Then, H and h_i are the height of the wall and the height at which the i -th restraining device is placed respectively.



Fig. 4 Examples of anti-seismic and traditional retrofitting techniques making use of timber: a) Bayt es-Suhaymi palace, Cairo, Egypt, XVII century; b) and c) The Kalà of Elbasan, Albania, XV century; d) detail of a capitol of the Dey Palace, Algiers, Algeria, XVI century; e) and f) Malatya, Turkey

Besides traditional strengthening systems pivoting on the use of timber elements to confer tensile capacities to masonry, innovative composite technologies exploiting organic or inorganic fibre textiles coupled to mortar matrixes are becoming increasingly widespread recently for masonry constructions (Alecci, 2015, 2016; Alecci, De Stefano, 2017; Alecci, Focacci, 2017; Misseri, 2019). Fibre textiles characterised by a loose mesh are applied in long strips at wall corners or as an all-around-wrap, eventually covering the full height of walls; the layout, acting as a bandage, provides an efficient confinement of the masonry box. This system has been proposed for earthen constructions in the in-depth research activities carried out at the Catholic University of Lima (Vargas, 2005; Blondet, 2007, Blondet, 2019).

Different fibres are employed to this aim, from polypropylene basalt or glass, to natural fibres, e.g. jute, cocoa, flax, hemp (Sidik, 2011; Sidik, 2015). The implementation requires that after arranging a primer layer of mortar, textiles are applied and then covered by a second layer of mortar in order to complete the reinforcing jacket. Composite jackets manufactured with mortar matrix based on lime, cement or earth, known as Textile Reinforced Mortars (TRM) or Fibre Reinforced Cementitious Matrix (FRCM), show thicknesses ranging around one centimetre. To evaluate the effect that this kind of reinforcement could provide to a reference masonry box of the kind shown in Table 2, the results of an experimental campaign are used (Fig. 5).

The reference composite was tested at the Official Testing Laboratory of the Department of Architecture, University of Florence. The innovative and sustainable reinforcement consists of an earthen-based mortar matrix and a balanced fibre glass mesh, i.e. a fibre mesh where warp and weft fibre bundles have the same cross section. The mesh grid spaces 12 mm and shows a cross section of 40 mm²/m in both warp and weft directions; the weight of the mesh is 220 g/m². The textile employed is made of alkali-resistant uncoated fibreglass and shows, according to the datasheet provided by the manufacturer, tensile strength 1.4 GPa and Young's modulus 74 GPa, elongation at rupture is 2%.

The test specimens consist of a 300 x 220 x 60 mm rammed earth block reinforced by a 200 x 200 mm composite sheet with thickness ranging 13-15 mm. The mortar employed for the jacket was made with the same raw earth together with 11% water and 0.5% of propylene fibres 20 mm long (percentages are related to weight of dry earth). The composite sheet was put in place through a specifically designed mould. After placing the mould on the block, a first layer of earthen matrix was applied. Then, on fresh mortar, the glass mesh was placed and covered by a second layer of the same mortar. The mould was removed after three days and drying was continued at standard temperature and humidity conditions for 28 days.

Each test specimen was placed on two cylindrical supports spaced 125 mm from symmetry axis and loaded by a 600 kN gauge load cell interposing an upper steel cylinder (Fig. 5a); tests were carried out in displacement control, the control parameter of the test is the displacement rather than force so as to acquire the load path also after peak load. Load and displacement measures were acquired through a

linear variable displacement transducer integrated into the test machine (INSTRON SATEC™ 5592-315 HVL-F2-G2). To evaluate the tensile force sustained by the reinforcement the following relation is employed:

$$f_{g-TReM} = \frac{5 P_{max} l}{16 b_j (h_b+h_j)} = 4.856 \text{ N/mm} \quad (6)$$

where, $\frac{P_{max} l}{4}$ is the maximum recorded bending moment, $b_j = 200 \text{ mm}$ and $\frac{4(h_b+h_j)}{5}$ are respectively the width of the jacket and the reduced height of the specimen. To define Equation (6) it was assumed that the tensile strength of the tested block is negligible. Moreover, it was assumed that the bending moment that balances the external action (i.e. $\frac{P_{max} l}{4}$) and activates tractions within the fibre reinforced composite jacket is defined on a reduced height of the specimen (i.e. $\frac{4}{5}$ of the total height). The results of three-point bending tests, in terms of force deflection diagrams, are showed in Figure 7b while in Table 2 are showed, for each specimen, the values of load required to evaluate Equation (6).

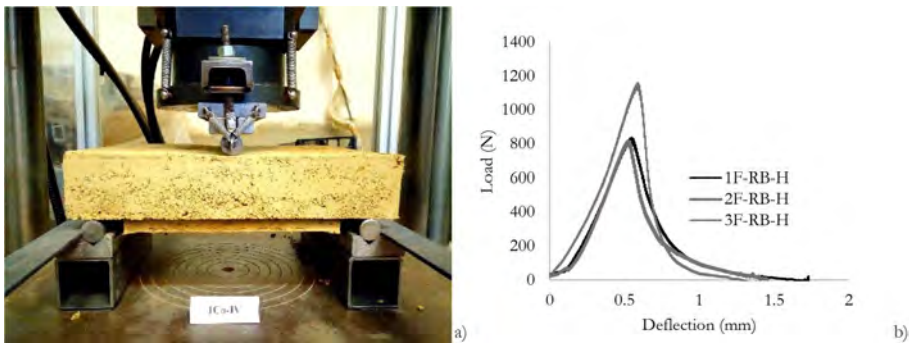

Fig. 5 a) The specimen 1F-RB-H subjected to three-point bending test; b) Load-deflection diagrams of the xF-RB-H specimens

Table 2 – Results (maximum recorded load and related deflection) of the three-point bending tests on the xF-RB-H specimens; l , b , and h_b are the dimensions of the brick, h_j is the height of the reinforcing jacket

Specimen	l [mm]	b [mm]	h_b+h_j [mm]	Max Load [N]	Deflection at Max Load [mm]
1F-RB-H	250	220	72	768	0.4246
2F-RB-H	250	220	74	819	0.3873
3F-RB-H	250	220	74.8	1160	0.5884
Average	250	220	73.6	915	0.4667
Standard Deviation				213	0.1069
Coefficient of Variation				0.233	0.2292

In the context of the linear kinematic analysis, to take into account the contribution offered by this reinforcement it is assumed that the maximum force per unit depth (dimension b in Table 2) recorded during three-point bending tests can be considered as the stabilizing force per unit height of a reinforcing jacket. For this kind of reinforcements, the effective length (minimum extension/length of the wrapping, i.e. dimension l in Table 2) is reached for few tens of centimetres after which the tensile capacity substantially does not increase (because the residual friction between fibre and matrix produces a very limited increase in load-bearing capacity). In fact, the design parameter governing the increase in tensile capacity is the extension in height of the strip or wrapping.

Finally, if the contribution of any retrofitting system is considered, the horizontal restraining force induced by frictional mechanism, and that counteracts the overturning mechanism, must be included in the computation of the load multiplier.

Corner keys and bond beams are particularly effective since they provide restraining forces without increasing the inertial masses, i.e. self-weights of timber elements, which were not considered relevant to the computation of the load multiplier value. If the contribution of the fibre textile composite is considered when evaluating the load coefficient, the tensile capacity must be included as a resistive force in the equilibrium balance expressed by the Virtual Works Equation.

Fig. 6 represents the values of the activation accelerations necessary to overturn the single rigid wall (RW) and assuming: the presence of a fibreglass textile one metre high (g-TReM), a bond beam (BB), a bond beam and a glass-fibre reinforcement strip of one metre height (BB+ g-TReM), as well as two corner keys and a bond beam (2CK+BB). To evaluate load coefficients of Fig. 6, it was assumed, referring to Equations (1-6): $q = 3.5\text{kN/m}^2$, $f = 2\text{ m}$ and $P_2 = 14\text{kN}$, $t_2 = \frac{t}{2}$, $t_{L,i} = 0.1\text{ m}$, $l_R = l_L = 1.5\text{ m}$ or 4 m for bond beams, $h_{m,i} = 1\text{ m}, 2\text{ m}$.

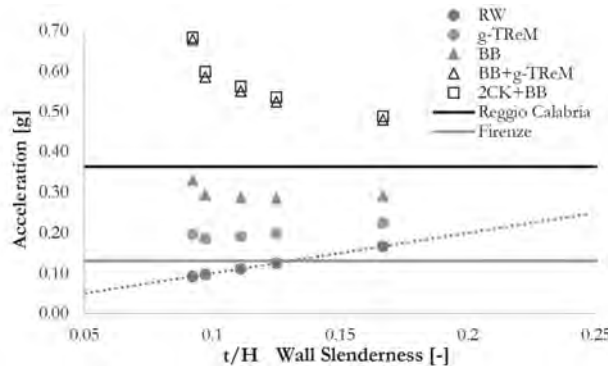

Fig. 6 Values of the activation acceleration necessary to overturn the single rigid wall (RW) and assuming: the presence of a one-metre high fibreglass textile (g-TReM), a bond beam (BB), a bond beam and a one-metre glass textile strip (BB+ g-TReM), as well as two corner keys and a bond beam (2CK+BB) superposed to the expected peak ground accelerations in Firenze and Reggio Calabria (Italy)

CONCLUSION

The investigation on seismic safety conditions of earthen buildings, exploiting a simplified case study, made it possible to draw some conclusions with reference to two reinforcement systems, a timber system and a fibreglass reinforced earthen plaster.

Considering the values of the activation acceleration necessary to overturn the walls of the case study, some considerations are possible. The use of corner keys in combination with bond beams, 2CK+BB series, provides activation acceleration levels comparable to that offered by the use of bond beams and one-metre-high strip of glass fibre textile reinforced earthen mortar (BB+g-TReM series). These solutions provide adequate safety margins also for those areas subjected to medium to high seismic hazard. Instead, the employment of the one-metre-high strip of glass fibre textile reinforced earthen mortar only (g-TReM series) would be satisfactory for most medium to low seismic hazard areas. Finally, the fibre composite solutions could be effectively employed for emergency repair or in restoration projects in which slabs modification could be hardly carried out.

BIBLIOGRAPHICAL REFERENCES

- Abdessemed-Foufa A.A., Benouar D. (2010). Investigation of the 1716 Algiers earthquake from historical sources: effect, damages and vulnerability. International Journal of Architectural Heritage. Taylor and Francis Group. London, England.
- Alecci, V., De Stefano, M., Focacci, F., Luciano, R., Rovero, L., & Stipo, G. (2017a). Strengthening masonry arches with lime-based mortar composite. *Buildings*, 7(2), p. 49.
- Alecci, V., De Stefano, M., Luciano, R., Rovero, L., & Stipo, G. (2015). Experimental investigation on bond behavior of cement-matrix-based composites for strengthening of masonry structures. *Journal of Composites for Construction*, 20 (1), 04015041.
- Alecci, V., Focacci, F., Rovero, L., Stipo, G., & De Stefano, M. (2017b). Intrados strengthening of brick masonry arches with different FRCM composites: experimental and analytical investigations. *Composite Structures*, 176, pp. 898-909.
- Alecci, V., Focacci, F., Rovero, L., Stipo, G., & De Stefano, M. (2016). Extrados strengthening of brick masonry arches with PBO-FRCM composites: Experimental and analytical investigations. *Composite Structures*, 149, pp. 184-196.
- Baglioni, E.; Fratini, F., Rovero, L. (2016). The characteristics of the earthen materials of the Drâa valley's architecture. *Journal of Materials and Environmental Science*, vol. 7, pp. 3538-3547.
- Baglioni, E.; Rovero, L.; Tonietti, U. (2016). Drâa valley earthen architecture: construction techniques, pathology and intervention criteria. *JOURNAL OF*

- MATERIALS & ENVIRONMENTAL SCIENCE, vol. Vol.7, pp. 3499-3508.
- Blondet M., Aguilar R. (2007), Seismic protection of earthen buildings, in Conferencia Internacional en Ingenieria Sismica, Lima, Perù 20th, 21st, 22nd august 2007.
 - Blondet, M., Tarque, N., Vargas, J., Vargas, H. (2019). Evaluation of a Rope Mesh Reinforcement System for Adobe Dwellings in Seismic Areas. In Structural Analysis of Historical Constructions (pp. 405-412). Springer, Cham.
 - Boostani, A., Fratini, F., Misseri, G., Rovero, L., Tonietti, U. (2018). A masterpiece of early Islamic architecture: The Noh-Gonbad Mosque in Balkh, Afghanistan. JOURNAL OF CULTURAL HERITAGE, pp. 1-9.
 - Briccoli Bati, S., Rovero, L., Tonietti, U. (2011). Experimental Analysis for Compressive Strength Evaluation of Earthen Materials. In Terra 2008: The 10th International Conference on the Study and Conservation of Earthen Architectural Heritage (p. 253). Getty Publications.
 - Briceño, C., Moreira, S., Noel, M.F., Gonzales, M., Vila-Chã, E., & Aguilar, R. (2018). Seismic vulnerability assessment of a 17th century adobe church in the Peruvian Andes. International Journal of Architectural Heritage, pp. 1-13.
 - Cancino, C., 2010. Damage assessment of historic earthen sites after the 2007 earthquake in Peru, Advanced Materials Research pp. 133-134, 665-670.
 - Centro Nacional de Conservacion and Restauration, 2010. Cartilla Patrimonio En Tierra, Sismo 2010, Consejo de Monumentos Nacionales, Gobierno de Chile.
 - Circ. NTC08, (2009). Circolare del Ministero delle Infrastrutture e dei Trasporti, n. 617 del 2 febbraio 2009, Suppl. Ord. n. 27 alla G.U. n. 47 del 26 febbraio 2009, "Istruzioni per l'applicazione delle nuove norme tecniche per le costruzioni di cui al decreto ministeriale 14 gennaio 2008".
 - D'Ayala, D., Benzoni, G. (2012). Historic and traditional structures during the 2010 Chile earthquake: observations, codes, and conservation strategies. Earthquake Spectra, 28(S1), S425-S451.
 - Fratini, F., Pecchioni, E., Rovero, L., Tonietti, U. (2011). The earth in the architecture of the historical centre of Lamezia Terme (Italy): Characterization for restoration. APPLIED CLAY SCIENCE, vol. 53 (3), pp. 509-516.
 - Gamrani, N., Chaham, K.R., Ibnoussina, M., Fratini, F., Rovero, L., Tonietti, U., Mansori, M., Daoudi, L., Favotto, C., Youbi, N. (2012). The particular "rammed earth" of the Saadian sugar refinery of Chichaoua (XVIth century, Morocco): mineralogical, chemical and mechanical characteristics. ENVIRONMENTAL EARTH SCIENCES, vol. 66 (1), pp. 129-140.
 - Gilbert, M., Casapulla, C., & Ahmed, H.M. (2006). Limit analysis of masonry block structures with non-associative frictional joints using linear programming. Computers & structures, 84(13-14), pp. 873-887.
 - Heyman, J. (1966). The stone skeleton. International Journal of solids and structures, 2(2), pp. 249-279.
 - Houben, H., Guillaud, H., Earth construction: a comprehensive guide ITDG Publishing, London (1994).
 - International Association for Earthquake Engineering (2004). Guidelines for

- earthquake resistant non-engineered construction. National Information Center of Earthquake Engineering. Kampur, India.
- Koocharian, A. (1952). Limit analysis of voussoir (segmental) and concrete arches. In *Journal Proceedings* (Vol. 49, No. 12, pp. 317-328).
 - Liberotti, G., Rovero, L., Stipo, G., Tonietti, U. (2016). Mechanical investigation on adobe samples belonging to the archaeological site of Arslantepe (Malatya, Turkey). *JOURNAL OF MATERIALS & ENVIRONMENTAL SCIENCE*, vol. 7, pp. 3656-3666.
 - Livesley, R.K. (1978). Limit analysis of structures formed from rigid blocks. *International Journal for Numerical Methods in Engineering*, 12(12), pp. 1853-1871.
 - Lourenço, P.B., Ciocci, M.P., Greco, F., Karanikoloudis, G., Cancino, C., Torrealva, D., & Wong, K. (2018). Traditional techniques for the rehabilitation and protection of historic earthen structures: The seismic retrofitting project. *International Journal of Architectural Heritage*, pp. 1-18.
 - Lourenço, P.B., Pereira, J.M. (2018) Recommendations for Advanced Modeling of Historic Earthen Sites: Seismic Retrofitting Project Research, Getty Conservation Institute.
 - Minke G. (2006). Building with earth. Design and technology for a sustainable architecture, Birkhäuser, Basel.
 - Misseri, G., Palazzi, C., & Rovero, L. (2020). Seismic vulnerability of timber-reinforced earthen structures through standard and non-standard limit analysis. *Engineering Structures*, 215, 110663.
 - Misseri, G., Rovero, L., Stipo, G., Barducci, S., Alecci, V., & De Stefano, M. (2019). Experimental and analytical investigations on sustainable and innovative strengthening systems for masonry arches. *Composite Structures*, 210, pp. 526-537.
 - NMAC (1982). New Mexico State Building Code, Section 2405 – Amendment, 1982.
 - NTC (2018) Aggiornamento delle "Norme Tecniche per le Costruzioni" D.M. 17 gennaio 2018, Suppl. ord. n° 8 alla G.U. n. 42 del 20/02/2018.
 - Oliver P. (1983). Earth as a building material today. *Oxford Art Journal* 5(2, Architecture): pp. 31-38. Oxford.
 - Omar Sidik D., Ridolfi F., Rovero L., Tonietti U. (2011). Experimental investigation on the anti-seismic effectiveness of textile-fibres net applied on earthen buildings. TerrAsia 2011. Mopko, Korea.
 - Omar Sidik D., Ridolfi F., Rovero L., Tonietti U. (2015). Diagonal tests on adobe panels reinforced by traditional and innovative anti-seismic retrofits. In: Proceedings of the International Conference on Vernacular Heritage, Sustainability and Earthen Architecture, Valencia (Spain), 11-13 september 2014, Taylor and Francis - Balkema, pp. 561-566.
 - Pacheco-Torgal, F., Jalali, S. (2012). Earth construction: Lessons from the past for future eco-efficient construction. *Construction and building materials*, 29, pp. 512-519.
 - Rovero, L., Tonietti, U. (2012). Structural behaviour of earthen corbelled domes

- in the Aleppo's region. *MATERIALS AND STRUCTURES*, vol. 45, pp. 171-184, ISSN:1359-5997.
- Rovero, L., Tonietti, U. (2015). The Jiayuguan Fortress: structural consistency and safeguarding programs. In: *Earthen Architecture: Past, Present and Future*, Valencia, 11-13/09/2014, CRC Press/Balkema, vol. 1, pp. 327-332.
 - Sinopoli, A. (Ed.). (1998). *Arch bridges*. CRC Press.
 - Tolles, E.L., Kimbro, E.E., & Ginell, W.S. (2003). *Planning and engineering guidelines for the seismic retrofitting of historic adobe structures*. Getty Publications.
 - Vargas, J., Blondet, M., Ginocchio, F., Villa-Garcia, G. (2005) "35 years of research on SismoAdobe". In Spanish. *Internacional Seminar on Architecture, Construction and Conservation of Earthen Buildings in Seismic Areas, SismoAdobe2005*. PUCP. Lima. Peru.
 - Vissilia A.M., Villi M. (2010). Adobe and timber ties as main construction materials for an historic greek dwelling. *International Journal of Architectural Heritage*. vol. 4:4, pp. 295-319. ISSN: 1558-3058 (Print) 1558-3066 (Online).

CONSERVATION OF EARTHEN ARCHITECTURE SITES IN CHINA

XIAO ZHOU, SHUAI TIAN

Conservation and Restoration Department, Chinese Academy of Culture Heritage - CACH, Beijing, China

Keywords: Earthen sites, anchoring, reinforcement materials, waterproof, earthquake prevention

INTRODUCTION

Most of the architectural cultural heritage in China is represented by earthen sites, but the conditions of these heritage sites are generally not good. In addition to being destroyed by human factors, these earthen sites are also subject to geological hazard (landslides, earthquakes, floods) as well to weathering caused by wind, rain, hydrothermal cycles, migration of groundwater and soluble salts, etc. Therefore, the conservation of earthen sites is an important part of the current protection of Chinese architectural cultural heritage. In the following paragraphs, the methods utilized for the conservation of Chinese earthen sites are illustrated.

ANCHORING AND GROUTING TECHNOLOGY FOR EARTHEN SITES

The number of earthen sites in China is large and their problems of conservation are serious. This means that the conservation work is mainly based on responding to emergencies and strengthening structures. Large-scale collapse is in fact the main problem affecting earthen sites (Wang, 2013). Therefore, the most important aspect in the reinforcement technology is the control of mechanical stability.

In the rescue and reinforcement project of the endangered earthen sites, the anchoring technology has become an important measure for controlling the mechanical stability of the earthen site due to its concealment and small disturbance of construction (Sun, 2010). The anchoring technology relies on the shear strength of the anchoring system to transmit the tensile force of the outward incline body. It is used to exercise the stability of the site itself, and effectively control the development of the crack.

Therefore, the use of anchor rods can preserve the sites for a long time.

After nearly 30 years of application, the anchoring technology of the earthen sites have become gradually reliable and standardized, and great progress has been made in the types of anchor, material of the grouting, anchoring process, anchoring system and its compatibility.

1. Type of anchor

In the early 1980s, anchoring technology was applied in projects for the cultural heritage sites protection in China, and the first application was in grottoes. In the 1990s, the first anchoring test on an earthen site was made by Li Zuixiong and others at the Pochengzi site in Anxi County, Gansu Province. Thin-walled steel pipes were used in that project (Li, 1997). Due to the uncoordinated deformation between steel and soil in the force mechanism, it is now rarely used in the anchoring of earthen sites.

1.1 Bamboo and wood anchors

Widely used in many earthen site conservation projects in China, bamboo and wood anchors have gradually gained wide recognition (Wang, 2009). In addition to the inherent characteristics of wood and the superiority of the wood structure itself, the wood anchor is also consistent with China's natural geographical environment, cultural orientation, architectural concept, architectural purpose and other factors. A large number of wooden structures have been preserved in the earthen sites of the northwest, which have been in use for more than 2,000 years and still play an important stabilizing role. Engineering practice and research have shown that the use of bamboo and wood anchors satisfies the need for compatibility with earthen sites.

1.2 Bamboo reinforced composite anchor

In the conservation projects of the Jiaohe site, Gaochang site and other large sites, the wooden and bamboo anchors alone were considered not to meet the requirements of the anchorage due to the large number of collapsing bodies with huge cracks cut. The Dunhuang Academy China has developed a bamboo-reinforced composite anchor. The inside of the anchor is a steel strand, the outer layer is a composite bonding material and bamboo, and the outermost layer is wrapped with a glass silk cloth. It can be seen in figure 1-2. The big cracks in the cliff of Jiaohe site have been successfully reinforced with bamboo-reinforced composite anchors (Sun, Li, 2008; Sun, Shen, 2008). This anchoring technology is a unique technology in China.

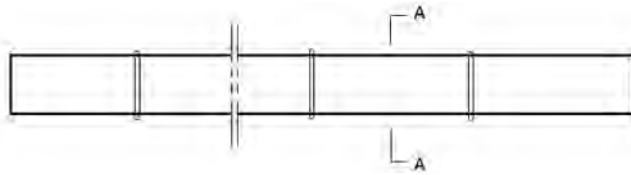

Fig. 1 Front view of the bamboo-reinforced composite anchor

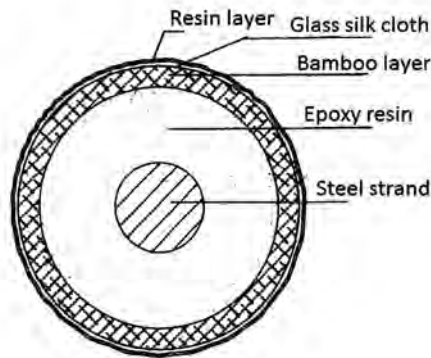

Fig. 2 A section of section of the bamboo-reinforced composite anchor

1.3 Other anchors

Other different types of anchors have been tried and used in the engineering of anchoring of earthen sites. Fiberglass anchors (GFRP) (Zhang, 2014), geotechnical filaments (Mao, 2008), carbon fibre bamboo anchors (Wang, 2009), Bakelite anchors and others have gradually been applied (Rong, 2016).

2 Type of grouting mortar

The requirements for mortar in the anchorage of earthen sites are different from those in geotechnical engineering. It requires that the strength of the mortar is higher than the strength of the earth, but not too much; otherwise, deformation will be uncoordinated, resulting in new damage. In addition to meeting the requirements of the soil's permeability coefficient, suitable cohesive force, and small shrinkage rate, it is also required to be compatible with the materials used in earthen sites. Cement mortar can provide sufficient anchoring force, but due to the large difference in the physical and chemical properties between cement mortar and earth, the migration and crystallization of soluble salts from cement toward earth, etc. it could be very dangerous for the site (Li, 2008). Therefore, a lot of research and application of more compatible grouting materials has been carried out.

2.1 Potassium silicate (PS) series grouting material

It is reported that the use of PS series mortar solved the problem of anchoring mortar in the earthen material. When anchoring the wall of the tomb No. 3 in Xixia ling tomb, in Yinchuan city, Ningxia province, PS+ fly ash and PS+ clay mortar were used. In the study of anchoring and reinforcement technology for the raw-earth site of Jiaohe, three kinds of mortar materials such as PS+clay, PS+ fly ash and PS+ (fly ash+clay) were selected, and the desired anchoring effect was obtained. It has been found that a weak interface exists between the anchor and the mortar. The mortar of different PS series has little influence on the anchoring strength (Sun, 2006; Sun 2007), and it is gradually applied to the small-body anchoring project of the earthen site.

2.2 Grouting material for calcined ginger nuts

In the large-scale archaeological excavation of the Dadiwan sites in Qin'an County, Gansu Province, the use of calcined ginger nuts was found in the ground floor. On this basis, a burnt calcined ginger nuts material with hydraulic and gas-hardening properties was developed. The material was obtained by calcinating ginger nuts in Quaternary loess at 1000 °C for 3 h (Li, 1988). Studies have shown that the burnt calcined ginger nuts has high mechanical strength and weather resistance, small shrinkage deformation, large porosity, good water permeability and good air permeability (Zhang, 2015). The modified material of quartz sand or silt mixed with the burnt calcined ginger nuts not only makes up for the shortcomings of the former materials, but also has good compatibility with earth materials. This material has also achieved good results in the reinforcement of earth sites.

2.3 Other grouting materials

In addition, there are mortars modified with silty clay, fly ash and cement. In the corresponding archaeological data and historical documents on the traditional cementitious materials (Wei, 2014), the glutinous rice pulp is used as a binder and mixed with lime, clay and sand to form a glutinous rice mortar (Peng, 2011). Considering the excellent fixing effect of the sand by means of modified polyvinyl alcohol (SH), organic polymeric materials have also been introduced in the anchoring of the earthen sites (Wang, 2016; Cui, 2017). The continuous innovation and research of grouting materials play an active role in promoting the anchoring technology of the earthen site.

3 Construction process

The anchoring project has the characteristics of invisibility and professionalism. Due to the particularity of anchoring projects of earthen sites, the safety of earthen cultural heritage is a prerequisite for construction. Therefore, the anchoring project of earth sites should avoid using modern equipment with excessive strength. It is usually to use light drilling rigs or manual drilling and during grouting activities are used low

pressure gravity grouting. The construction season is also important to the anchoring of the earthen site. If the temperature is too low, it will directly affect the hardening of the grouting material so the intervention should not take place in winter. At the same time, selecting appropriate construction methods according to engineering conditions and geological conditions is also essential to improve construction efficiency (Ren, 2010). The construction technology (Fig. 3 a-f), mainly includes artificial hole forming anchors installation, grouting, slotting, penetration strengthening, pad installation, anchor hole sealing and maintenance (Ren, 2009). The experience of the construction workers directly affects the construction quality, so only a construction company with certain professional experience should undertake the work.



Fig. 3a Artificial drilling



Fig. 3b Bolt installation



Fig. 3c Grouting



Fig. 3d Enlargement of the hole



Fig. 3e Pad installation



Fig. 3f Sealing the hole

REINFORCEMENT MATERIALS FOR EARTHEN SITES

Surface weathering is one of the important decay processes affecting earthen sites. Therefore, surface reinforcement is an important part of the earth protection project. The main types of materials currently used for the protection of earthen sites are shown in Fig. 4.

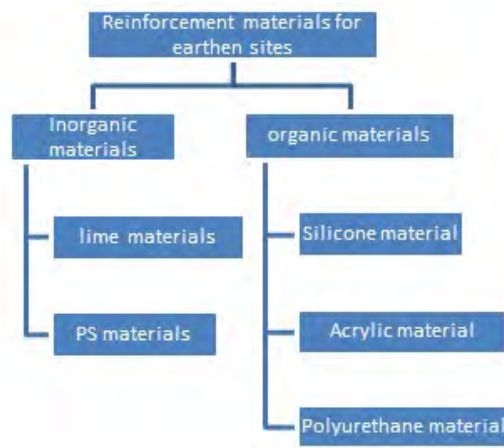

Fig. 4 Category of reinforcement materials for earthen sites conservation

1 Inorganic materials

At present, there are mainly two kinds of inorganic materials used for the protection of earthen sites: the lime-based materials, which are mainly used mixed with earth for concrete construction and the potassium silicate (PS) based materials, which are mainly used for surface consolidation.

1.1 Lime materials

In construction engineering, building mortar plays an important role in bonding loose-grained materials (such as sand and stones) and bulking materials (such as bricks and stones) into a whole (Liu, 2009). Some of the traditional materials used in ancient buildings have been found to have a good reinforcing action. These materials are based on inorganic materials such as lime and are blended with natural bio-materials such as glutinous rice syrup or egg white. They present significant advantages in terms of durability, strength and compatibility with the building body.

Zhejiang University's analysis of ancient mortar samples in the Ming Dynasty city walls of Xi'an shows that when the glutinous rice slurry and lime are mixed, the reinforcement performance will be greatly improved. These properties include bonding properties, compressive strength, surface hardness, and water immersion resistance. They show that the performance of glutinous rice mortar is good and scientifically

reasonable. Traditional glutinous rice mortar has been used for thousands of years. It has good compatibility with ancient buildings and no environmental pollution. It can be recommended as a repair material for ancient buildings today (Yang, 2008).

1.2 PS materials

There are a large number of earthen sites in the north western part of China. Most of these earthen sites are made of sand, silt, and silty clay. These earthen sites show very bad conditions of conservation due to strong winds and concentrated heavy rainfall.

The PS material is a relatively low molecular weight, water-soluble inorganic binder. The chemical formula is $K_2O \cdot nSiO_2$. The ratio between the number of molecules of SiO_2 and K_2O in an aqueous solution of potassium silicate is called the modulus. Reinforcement is generally carried out with a PS with a modulus of 3.84, which is considered a high modulus potassium silicate material. The general use concentration of PS solution is 3% -10%. It is obtained starting from a concentration of 25% of the PS stock solution, diluted with water, up to the desired concentration of PS solution. The prepared PS solution is mixed with a certain amount of curing agent ($CaSiF_6$), cross-linking agent [$Al_2(SiO_3)_3$], and stirred uniformly. Finally, about 10 ppm of the diffusing agent NNO is added, and evenly stirred, it can be directly sprayed or dripped (Li, Wang, 1998; Li, Wang et al., 1998).

In 1983, Li Zuixiong of Dunhuang Research Institute tried to reinforce the Dadiwan site of the Neolithic Age, Qin'an city, Gansu Province by using PS infiltration, and achieved obvious anti-weathering effects. In 1992, based on laboratory research, the Dunhuang Research Institute conducted a large number of field tests in the Han Dynasty's Pochengzi Site in Anxi County, Gansu Province, the Turpan Jiaohe Site, the Xi'an Banpo Site and the Qinyongkeng site (Li, 1995; Li, 1997). Through the aforementioned numerous indoor and field tests, the modulus, concentration and some process methods of the PS to reinforce the earthen sites were obtained.

In 1998-2002, PS materials were used to protect and reinforce the earthen sites such as Yumenguan, Hecangcheng, Ningxia Xixiawangling No. 3 tomb, and the observatory of Jiaohe Site, achieving obvious reinforcement effects (Li, 2003). In recent years, Li Zuixiong, Wang Xudong, Sun Manli and others, combined with the reinforcement and protection project of the Jiaohe Site in Turpan, Xinjiang, have further studied the main decay processes of the Jiaohe Site. According to the results of a large number of indoor and outdoor experiments, the main engineering measures and technical methods for strengthening the site were summarized. These technical methods have been used in the rescue and reinforcement project of Jiaohe Old City, and have achieved obvious protection effects (Wang, 2002).

2 Organic materials

At present, there are three main types of organic materials used for the protection of earthen sites: silicones, acrylates and polyurethanes. Because of the significant

shortcomings of a single type of material, the major organic materials developed in recent years are all modified materials.

2.1 Silicone material

There are two types of silicone based products such as the AWS-VX silicone system ([P] DE.2733686) - an organosiloxane - and the ethyl silicate series from Remmers and Wacker (Germany) which can be used as sealants for surfaces or as reinforcing agents.

Since 1959, China has used chemical materials on the reinforcement and protection of Banpo Site. For many years, reinforcement material such as ethyl silicate, long-chain alkyl silicone, and polyester acid vinyl acetate have been used. The ageing tests evidenced that after several years after the application only ethyl silicate has a slight effect on strength and permeability (Li, 2003).

RTV material is a kind of silicone material which can be cured at room temperature. It was developed for the protection of earthen sites in a wet environment by Zhejiang University. It combines the characteristics of ethyl silicate and short-chain polysilane. The indoor tests and field experiments of Liangzhu Site indicate that for the earth with a water content of 11.7-21.7%, it has a certain reinforcing effect and good waterproof and water resistance, and it does not change the appearance. 34WD-10 material is a long-chain silicone product produced by WuDa Silicone New Material Co. Ltd. Its main component is lauryl trimethoxysilane. In recent years, it has been used as a waterproofing agent in many cultural relics protection. WD-S is a waterproof material produced by Wuhan Luke Cultural Relics Co., Ltd. Its main component is water-based oligomeric methoxysilane, which has been used as a waterproof material for bricks (Zhou, 2004).

2.2 Acrylate materials

Acrylic resin is a polymer formed by an acrylic monomer under the action of a catalyst. It is widely used in many fields due to its excellent weather resistance. It can be used as a reinforcing agent, binder in cultural relic protection. There are various solvents for acrylic resins, such as benzenes, ketones, esters, chlorinated hydrocarbons, etc. It is difficult to apply acrylic resins in deep reinforcement due to the solute migration which causes a concentration of the product on the surface. After the solvent has been volatilized, the surface colour deepens and a surface crust forms. The film of this polymer has the following adverse effects: preventing moisture from migrating outward, then causing an internal enrichment of moisture. Since the thermal expansion coefficient of the shell is different inside and outside, it is easy to break due to tension during thermal cycles.

Currently, to improve the performance of acrylic resin, the following methods are generally used:

- a fluorine-containing structural unit is introduced, such as the new protective agent perfluoropolyether. Liang Guozheng et al. used a fluorocarbon-based

- multicomponent copolymer to improve the experiment in strengthening Banpo site (He, 2001; He, 2002);
- a structural unit containing silicon is introduced. Li (2009) synthesized an acrylic-silicone-epoxy composite system reinforcement material for the humid climate in southwest China. This material has been successfully applied to the reinforcement of the Jinsha site in Chengdu; it has significantly improved the water resistance, acid mist resistance and alkali resistance of the soil.

2.3 Polyurethane material

Polyurethane materials are organic materials widely used in coatings, adhesives, and chemical grouting materials. They are formed from the polycondensation of isocyanates and polyols. There are many types of isocyanates currently used, such as toluene diisocyanate, diphenylmethane diisocyanate, polymethylene polyphenyl polyisocyanate, etc. The materials used in earth protection are modified polyurethanes, the solvent is an aromatic hydrocarbon - n-butyl acetate, and the diluent is xylene - butanone. The advantage of this material is the fast penetration, deep penetration, the high reinforcement strength and the good water resistance; the disadvantage is that the colour changes considerably after reinforcement, and the poor aging resistance. The material is toxic and requires a large amount of organic solvent. During the manufacturing process, the operator is severely exposed and the toxic component remains for a long time after use. Lanzhou University polymerizes polyurethane and polyacrylate to form urethane acrylate (PUA), which was used for the consolidation protection of the ancient city of Jinyang, Shaanxi Province with good performances (Shen, 2016).

WATERPROOF AND MOISTURE-PROOF TECHNOLOGY FOR EARTHEN SITES

According to the investigation of multiple sites, the measures for water and humidity reduction of earthen sites in wet areas in China mainly include the following methods: water retaining wall, impermeable corridor, pumping method and arch coupon method (Table 1). The principles used in the various methods are different (Zhou, 2009).

Table 1 - Methods for reducing water and moisture on earthen architecture

Measures	Case studies	Effect evaluation	Disadvantage
Water-retaining wall	Tianzijialiu Site, Luoyang	Still damp	The water movement cannot be controlled in the lower part
Impermeable corridor	Beijing Dabantai Site Museum	Effective; the penetration of rainwater can be blocked	The water movement cannot be controlled in the lower part
Pumping method	Du Fu Caotang Site	Effective; microbial growth cannot be prevented	Easy to cause collapse of the earthen artefact
Arch method	Xunmakeng Site, Linyi Shandong, Zhenghan Site, Xinzhen, Henan	Good effect; the problem of groundwater can be solved	Difficult to operate; high cost

1 Evaluation of various methods

1.1 Water-retaining wall

The principle of water-retaining wall is to form a water-repellent layer around the site, which can cut off the water from the side. The disadvantage of this method is that it cannot solve the water infiltrated from below. If the level of the groundwater is high, or unstable, there will be no good effect. If the ambient humidity changes cyclically, the salt crystallization will cause the disaggregation of the earthen artefacts. If the retaining wall is leaky or the waterproof material is aging, it will easily fail.

1.2 Impermeable corridor

As in the case of the water-retaining wall, the function of the impermeable corridor is to prevent the water penetration of the side. Unlike the former, the space is increased in the middle, the ventilation facilities can be increased in this space, the water isolation efficiency can be improved, and maintenance is also easy.

1.3 Pumping method

The function of pumping is to actively reduce the groundwater level and the water content of the upper soil. The pumping method is applicable to the groundwater level within a certain height range. If the groundwater level is too low, it is not necessary to use it; if the groundwater level is too high, pumping cannot solve the problem. In addition, if the body of the soil is very permeable, the pumping method cannot solve the problem, because it is too expensive. Another disadvantage of the pumping method is that the pumping water tends to cause concentrated flow of water, which causes the soil particles to be carried away, resulting in the destruction of the soil structure, causing the local soil to sink.

1.4 Arch method

Arch method is to cut off the connection between the site and the groundwater, thus preventing the damage caused by the rise of groundwater. The advantage of the arch method is that it can completely isolate the influence of groundwater. The disadvantage is that it is difficult to realize and costly. In the case of high groundwater level, the operation is more difficult. If the structure is flawed, this method is easy to fail. The design of the arch method should be comprehensive, and the surrounding and the lower part must be considered. Otherwise, it is easy to cause partial damage, such as the situation of Linyi Che Ma Hang.

Arch method can solve the problem in case of groundwater level not too high, such as in the Xinzheng Chemakeng site. Nevertheless, we should pay attention not to modify the site during the excavation process.

2 Results and discussion of the measures against water and humidity in earthen structures

2.1 Results

Many interesting experimentations have been carried out in the waterproofing of earthen sites. In the "waterproof project" of Chinese sites, the methods used are the following: the retaining wall method, the waterproof corridor method, the pumping method, and the arch method. Each one of these methods has its own advantages and disadvantages. Among them, the arch method shows the best effect but several other methods have a certain effect on isolating water and moisture from the site.

2.2 Discussion

The choice of the above methods (table 1) must be based on the actual conditions of each site, and then it is necessary to carry out a complete geological survey in order to understand the stratigraphy and groundwater conditions before making a decision.

The destruction of earthen sites by groundwater and rainwater is a problem that must be overcome in the protection of earthen sites. In addition to the above

methods, there are some measures that can be undertaken, such as cutting the earth and sealing all. The method of cutting the earth has been applied in the No. 6 pit of the Terracotta Warriors and Horses of Qin Shi Huang. This site is a long strip-shaped burial pit. The stratigraphy of the site is the following: a 2-meter-thick alluvial layer was covered on the earthen site by using rammed earth technology. For the exhibition, the upper layer was excavated in the outside in order to form a wide walking trail. As a result, leaking of external rainwater, weathering, moulds growth, etc. mainly occurs in this part. Thus, the lower layer slowly releases water and gradually balances with the environment. The method of cutting earth can be carried out to counteract the effects of rain in case of a wet earthen site.

Another method was used at the Xianyangling site: the site was completely sealed to keep the environment of the remains highly humid, more than 80%. The purpose of this procedure is to avoid the evaporation of water, so even if there is high moisture content in the lower part of the site, it will not cause damage. Disadvantage is that it needs frequent anti-mildew treatments. The glass used in the site should also be a special material that can drive away the moisture that has condensed on the glass.

EARTHQUAKE PREVENTION MEASURES FOR EARTHEN SITES

1 Principle of seismic reinforcement

The seismic reinforcement of the earthen sites (Shi, 2013) should take into account the following principles:

(1) The protection and management of cultural heritage should follow the principle of "not to change their original appearance, focusing on the prevention of the destruction of the natural environment of the earthen site. The exposed engineering facilities should be concealed and managed to be in harmony with the surrounding environment in order to achieve the purpose of keeping the original appearance as much as possible.

(2) The resistance to seismic events should be appropriately increased: most of the earthen sites are represented by residual thin walls often with irregular shape, requiring difficult anti-seismic interventions.

(3) The interaction between the structure of the earthen site, the foundation and the surrounding environment should be considered. The reinforcement of the foundation and the comprehensive improvement of the surrounding environment are the basis for the reinforcement of the earthen site.

(4) In many cases, the seismic improvement interventions require several phases spread over time, therefore sufficient space should be reserved to follow the principle of reprocessing, which will facilitate for the future reinforcement interventions.

(5) Considering the non-renewability of the earthen site, an analogy test should be carried out before the implementation of the reinforcement project to verify the

feasibility of the design. At the same time, the reinforcement materials and processes should be scientifically tested to prove that they are harmless to the cultural artefacts and can be used after long-term protection, ensuring that the artistic value of the cultural artefact is not impaired.

(6) The safety of visitors is the primary goal of the seismic improvement of earthen sites.

2 Comparison between seismic improvement and general reinforcement

The ultimate goal of both reinforcement methods is to control the problem of conservation of the earthen site, so that it could be in safe conditions for a longer period.

The reinforcement principle is basically the same but the difference is the object of the reinforcement. The general reinforcement takes into account the different decay problems like weathering, water erosion, fracture development etc. The seismic improvement is mainly addressed to poor stability, risk to collapse under the action of earthquake, geological hazard in general.

Another difference is the reinforcement effect. The general reinforcement of an earth site is aimed at coping with various conservation problems and requires skilled restorers capable to satisfy the principle of "restoring the old as old". The seismic reinforcement of an earthen artefact mainly considers the safety condition of an earthen site subjected to an earthquake.

Finally, there is a difference in the reinforcement methods: the general reinforcement is usually based on chemical reinforcement while seismic reinforcement is usually based on physical reinforcement or a combination of physical reinforcement and chemical reinforcement.

3 Seismic reinforcement of earthen sites

3.1 Physical reinforcement

Physical reinforcement refers to change the stress and strain state of the earth through physical mechanical reinforcement, thereby increasing the stability of the earthen sites. Common physical reinforcement methods are as follows: adobe laying, pebble laying, bracket support, earth nail anchoring, foundation reinforcement, retaining wall reinforcement, and anchor reinforcement, etc.

3.2 Chemical physical reinforcement

Chemical physical reinforcement refers to the combination of physical reinforcement and chemical reinforcement. It mainly combines the advantages of the two reinforcement methods to adjust the mechanical properties and chemical composition of the earth to obtain the optimal reinforcement effect. Grouting and anchoring are relatively mature chemical and physical methods.

In view of the variety of conservation problems and types of earthen sites, some seismic reinforcement methods are proposed, as shown in the following Table 2.

Table 2 Anti-seismic reinforcement for earthen site with different problems of conservation

Conservation problem	Adobe laying	Anchor reinforcement	Foundation reinforcement	PS Grouting	Bracket support	Retaining wall reinforcement
Crack	•	•		•		
Missing	•	•			•	
Erosion	•	•		•		•
Settlement		•	•			•
Cliff		•				•

The results of the different methods of seismic improvement show that grouting and anchor reinforcement are a good solution. From the perspective of improving seismic performance, the anchor reinforcement can enhance the coupling ability of the relatively independent portions. Nevertheless, the large cracks should be treated with the combined action of grouting and anchoring.

BIBLIOGRAPHICAL REFERENCES

- Cui K., Wang D.H. et al. (2017), "Study on the Performance and Mechanism of Slurry Coating Based on SH-(C+F)", in *Chinese Journal of Engineering Geology*, 25(1), pp. 19-26.
- He L., Liang G.Z. (2002), "Study on the Protection of Earthen Sites by Partial Fluorinated Polymer", in *Dunhuang Research*, 6, pp. 92-98.
- He L., Zhen G.Q. (2001), "Research on Reinforcement of Banpo Site", in *Archaeology and Heritage Collection*, 5, p. 107.
- Li J.J. (2003), *Human Cultural Heritage Protection (1)*, Xi'an, pp. 21-24.
- Li Z.X. (1988), *The Oldest Concrete in the World*, in *Chinese Journal of Archaeology*, 8, pp. 751-756.
- Li Z.X. (2003), *Conservation of Earthen Sites on the Silk Road*, Beijing, pp. 25-26.
- Li Z.X. (2008), *Protection of Ancient Site on Silk Road*, Beijing, pp. 118-122.
- Li Z.X., Wang X.D. (1997), "New Progress in Research on Reinforcement of Ancient Earthen Sites", in *Dunhuang Research*, 4, pp. 167-172.
- Li Z.X., Wang X.D. et al. (1997), "The Reinforcement Test of Jiaohe Site", in *Dunhuang Research*, 3, pp. 171-177.
- Li Z.X., Wang X.D. (1998), "Reinforcement Test of Indoor Earthen Sites - Reinforcement Test of Banpo Earthen Site", in *Dunhuang Research*, 4, pp. 144-153.
- Li Z.D., Wang X.D. et al. (1998), "The Reinforcement Test of Qingyongkeng Site", in *Dunhuang Research*, 4, pp. 151-158.
- Li X.J., Wan T. et al. (2009), "Study on Preparation and Properties of Reinforcement

- Materials for Jinsha Site", in *Materials Science and Technology*, 4, pp. 215-220.
- Li Z.X., Zhang H.Y. (1995), "Research on Reinforcement of Ancient Earthen Sites", in *Dunhuang Research*, 3, pp. 1-17.
 - Liu J.Z. (2009), *Architecture Material*, Beijing, pp. 103-105.
 - Mao X.K., Zhao D. et al. (2008), "Anchorage Theory and Experimental Study of Geotextile Filament", in *Chinese Journal of Mechanics and Practice*, 30(2), pp. 74-77.
 - Peng H.T., Zhang Q. et al. (2011), "Effect of Glutinous Rice on the Properties of Triple Soil for Restoration of Earthen Sites", in *Chinese Journal of Building Materials*, 14(5), pp. 718-722.
 - Ren F.F., Shen W.W. et al. (2009), "Research on Construction Technology Optimization of Bamboo-reinforced Composite Anchor", in *Chinese Journal of Rock Mechanics and Engineering*, 28 (S2), pp. 3789-3794.
 - Ren F.F., Yang Z.J et al. (2010), "An analytical analysis of the full-range behavior of grouted rock bolts based on a trilinear bond-slip model", in *Chinese Journal of Construction and Building Materials*, 24(3), pp. 261-270.
 - Ren X.R., Zhang H.K. et al. (2017), "Performance of Grout Mixed with Calcined Ginger Nuts and Earthen Fabric in Anchoring Conservation of Earthen Sites", in *Chinese Journal of Materials Science and Engineering*, 35(1), pp. 62-66.
 - Rong Y., Li Y. et al. (2016), "Application of Bakelite Rod in Anchorage of Tangguangcheng Hanguangmen Site", in *Journal of Shaanxi Normal University (Natural Science Edition)*, 44(3), pp. 69-74.
 - Shen X.W. (2016), *Mechanism Analysis of the Wall of the West Wall of Jinyang Site and Experimental Study on Reinforcement Materials*, Lanzhou, pp. 69-70.
 - Shi Y.C., Wang X.D. et al (2013), "Earthquake Damage Prevention and Seismic Strengthening Counter Measures for Earthen Sites", in *Chinese Journal of Earthquake Engineering*, 3, pp. 42-50.
 - Sun M.L., Wang X.D. et al. (2006), "Study on the Reinforcement of Earthen Sites with Wooden Anchors", in *Chinese Journal of Geotechnical Engineering*, 12, pp. 2156-2159.
 - Sun M.L. (2007), Current Status and Progress of Research on Earthen Sites Protection, in *Chinese Journal of Sciences of Conservation and Archaeology*, 19 (4), pp. 64-70.
 - Sun M.L., Li Z.X. et al. (2008), "Study on Reinforcing Earthen Sites with Bamboo-reinforced Composite Anchor", in *Chinese Journal of Rock Mechanics and Engineering*, 27(S2), pp. 3371-3381.
 - Sun G.J., Shen W.W. et al. (2008), "Experimental Study on Pulling of Bamboo-reinforced Composite Anchor", in *Dunhuang Research*, 6, pp. 29-33.
 - Sun M.L., Wang X.D. et al. (2010), *The Protection of Earthen Sites*, Beijing, pp. 1-3
 - Wang D.H. (2016), "Study on Anchorage Performance and Mechanism of Modified Glutinous Rice Mortar and SH Mixed Slurry Anchor", in *Earthen Sites*, Lanzhou, pp. 15-17.
 - Wang D.Y. (2009), *Application and Research of Anchor Rod Technology in Earthen Site Protection*, Xi'an, pp. 1-5.

- Wang X.D. (2002), *Study on Protection and Reinforcement of Grottoes and Earthen Sites in Arid Environment in Northwestern China*, Lanzhou, pp. 85-86.
- Wang X.D., Zhang H.Y. et al.(2009), "Experimental Study on Mechanical Properties of Bamboo-reinforced Composite Anchor", in *Journal of Rock Mechanics and Engineering*, 28 (S1), pp. 2941-2946.
- Wang X.D., Li Z.X. et al. (2013), *Research on Key Technologies of Earth Sites Protection*. Beijing, pp. 1-2.
- Wei G.F., Fang S.Q. et al. (2014), "Effect of rice pulp type on the performance of traditional mortar", in *Chinese Journal of Building Materials*, 17(4), pp.618-622.
- Yang F.W., Zhang B.J. (2008), "Exploratory Research on the Scientific Principles of Traditional Glutinous Rice Mortar and Its Modern Application", in *Palace Museum Journal*, 9, pp. 105-114.
- Zhang J.K., Shen W.W. et al. (2014), "Field test study on anchorage performance of GFRP anchors in reinforcement of Earthen sites", in *Chinese Journal of Engineering Geology*, 22(5), pp. 804-810.
- Zhang J.K., Chen W.W. et al. (2015), "Study on Workability and Durability of Calcined Ginger Nuts-based Grouts used in Anchoring Conservation of Earthen Sites", in *Chinese Journal of Culture Heritage*, 16(6), pp. 831-837.
- Zhou S.L., Yang Q. et al. (2009),"Comparative Study on Moisture-proof Technology of Damp Earthen Sites", in *Chinese Journal of Southeast Culture*, 6, pp.95-98.
- Zhou H., Zhang B.J. et al. (2004), *Moisture Curable Silicone for Conservation and Protecting Ancient Earthen Sites in Moisture Environments*, Second International Conference on the Conservation of Grotto Sites Abstracts, pp. 56-60.

PART 4

**NEW PERSPECTIVES IN EARTHEN
ARCHITECTURE IN ITALY AND CHINA**



OVERVIEW OF CONTEMPORARY EARTHEN ARCHITECTURE IN ITALY

ELIANA BAGLIONI

Architect and independent researcher – Perugia – Italy

Keywords: Contemporary earthen architecture, traditional earthen architecture, earthen material property, recovery of existing buildings, eco-sustainable architecture

INTRODUCTION

Speaking of contemporary earthen architecture in Italy is a very thorny subject since at first glance the raw earth does not seem to be present in current building productions. Nevertheless, at a closer and more curious look, we realize that there are a rich series of small buildings, which make this material gradually re-acquiring space and credibility in the contemporary architectural scene.

Unfortunately, if it is true that in Italy, as in the rest of the world, there is a rich and varied earthen building heritage, it is also true that it is predominantly a rural heritage, which attracts the scientific and cultural interest of researchers and professionals, but that continues to be unknown or little appreciated by most of the people.

Definitively abandoned as a building material from the 1950s in favour of the industrialized materials, more “advanced” and “resistant” and linked to a status of “modernity”, the raw earth is still a victim of prejudices. In fact, its variability in composition limits its use in an increasingly standardized and necessarily regulated construction sector but it is really an added value because it gives rise to many possible construction techniques, a diversity that is the richness of our world.

The artisan soul of the raw earth struggles to make space in the Italian architectural scene, but not all is lost.

THE VERNACULAR EARTHEN BUILDING HERITAGE

The traditional earthen architecture is really varied and rich all over the world and also in Italy many differences can be observed. Earthen constructions, in fact, are

part of the built heritage of many Italian regions and, as it happens in other contexts, the construction techniques differ from territory to territory, in relation to the type of available earth, to local construction cultures, to the functional and housing needs of the places (AA. VV., 2012; Bertagnin, 1998; Conti, 2004).

Buildings in earthen blocks, commonly known in the scientific context with the name of *adobe* or mud brick, characterize many historical centres of the Campidano territory (Sardinia), where they are called by the local name of *ladiri* (Achenza et al., 2008). The use of earthen blocks is also common in other regions such as Piedmont, in the Asti area (AA. VV., 2008), or in Calabria, where adobe are often used together with a wooden framework (Chimirri, 1999), this solution is also found in other zone of the world with characterized by a high seismic risk such as Calabria.

In Marche and Abruzzo regions (Rasicci, 2007), it is common the use of *massone*, a technique of hand shaping of the masonries, that utilizing a mixture of earth and straw, which recalls the techniques of cob in Ireland and *bauge* in France.

In Piedmont, especially in the area between Alessandria, Novi Ligure and Tortona there are many farms built with the rammed earth technique (*pisé* in French) (Mattone et al., 2010).

Although the aforementioned cases are the best known and widely documented, even today the existing built heritage allows us to discover new buildings and constructive cultures in raw earth scattered throughout the country. This is the case of Emilia Romagna where, following the damage caused by the 2009 earthquake, have been made visible numerous buildings with a double layers masonries made of fired brick wall facing outwards and raw earth blocks inwards. Also in the central valley of Umbria have been discovered many buildings made both in raw earth blocks and rammed earth, covered with stone or fired bricks walls (Baglioni, 2016).

Therefore, while on the one hand much of the earthen building heritage has been lost, due to the abandonment or replacement of buildings realized with "modern materials", many others are yet to be discovered.

THE EARTH IN THE RECOVERY OF THE EXISTING BUILDING HERITAGE

The recovery of existing buildings and traditional construction techniques is one of the fields which raw earth is used in contemporary construction, thanks to the intense work of transmission of knowledge carried out both by Associations and by careful researchers and professionals and lovers of earthen architecture.

Regarding the associations, interesting examples are the Documentation Centre on "Case di Terra" in Casalıncontrada in Abruzzo (<http://casediterra.com>) and the "Città della Terra Cruda" Association (<http://www.terracruda.org>), which puts in network municipal administrations, both Italian and foreign, in which territories are present raw earth constructions.

Some noteworthy results are the following:

- 1 the recovery of rural buildings such as "Borgocapo" and "Casa di Teresa", in Casalincontrada, Abruzzo (<https://www.archilovers.com/projects/212497/la-casa-di-teresa.html>);
- 2 the recovery of many houses in Sardinian historical centres for residential and tourist purposes, such as the "Ventanas Bed and Breakfast" (<http://www.ventas.it>);
- 3 the recovery of an entire urban district, called "Villa Ficana" (Conti, 2004; AA. VV., 1998), just outside the historical centre of Macerata. This urban district, after the recovery, is again inhabited and has become a cultural reference for the city thanks to the creation of an Ecomuseum (<https://www.ecomuseoficana.it>) (Figg. 1 and 2).
- 4 the recovery of some farmhouses in Piedmont for residential purposes (Bollini, 2013).



Fig. 1 Exterior of a recovered house in Villa Ficana, Macerata, Italy (Credit by E. Baglioni, 2015)



Fig. 2 Interior of a recovered house in Villa Ficana, Macerata, Italy (Credit by E. Baglioni, 2015)

RAW EARTH IN NEW CONSTRUCTIONS

Eco sustainable architecture

Another field of use of raw earth in Italian contemporary architecture is closely linked to the broader sector of sustainable architecture.

In this context, the raw earth is enhanced and used for its technical characteristics that make it a material fully suited to the standards of bioecological architecture. These standards aim to create buildings in harmonious balance with the places in which they are inserted, respectful of the environment and health of the users who live there (Source: ANAB-National association of bioecological architecture, Italy) <http://www.anab.it/>. The bioecological architecture tries to use eco-sustainable materials and techniques, which favour the achievement of energy efficiency through bioclimatic strategies, passive contributions - which maximize positive the thermal exchange between building and environment - and the use of renewable energy sources for the operation of the installations.

Despite the "Kyoto Protocol" - at international value - and the "20-20-20 Plan" - with European level- the construction sector continues to maintain negative records in terms of pollution and waste production, consumption of raw materials and energy consumption for production, damage to the territory and to the landscape.

Therefore, first as human beings, than as professionals, we have a great ethical and moral responsibility to limit the depredation of territories and resources and make conscious choices aimed at taking care of ourselves, of the future generations and planet in which we live.

Raw earth and eco sustainable architecture

The raw earth responds very well to the objectives of bioecological architecture. As a matter of fact earth is a material available locally in many environmental contexts, it is natural and reusable. Moreover, if not contaminated by anthropogenic chemical agents, the raw earth does not pollute and can also be re-introduced into the ecosystem; it does not contain nor emit harmful substances, both in outdoor and indoor environments.

Even when it is processed industrially, it undergoes low levels of transformation and therefore has a low energy consumption of production. Moreover, not undergoing a firing processes, it does not emit climate-altering agents and polluting particulates.

The raw earth is in all aspects an ecological material with a low environmental impact as it has a virtuous life cycle - from extraction to processing, use and disposal (Tomasi, 2012) - which in the long term keeps environmental resources unchanged.

Characteristics of the earth material

From a strictly technical point of view, raw earth is a material that deserves to be used in contemporary architecture as it has many interesting characteristics. It has a high thermal inertia, functioning as a heat accumulator - heating and cooling slowly - and therefore ensuring an indoor microclimate fresh in summer and warm in winter. It is a transpiring material, allowing the migration of water vapour from the inside towards the outside of the building, so consequently preventing the accumulation of humidity and the onset of superficial moulds that can cause respiratory and allergic diseases. It performs the function of hygrometric regulator, i.e. absorbs moisture from the air and releases it when the indoor environment is drier, keeping the internal relative humidity almost constant during the day and the seasons. Moreover, it absorbs sound waves and purifies the air by absorbing odours and smoke.

All the aforementioned characteristics contribute to keep the environments in healthy conditions with a high living comfort; it is not a coincidence that earth it is the oldest material used by man, from the Neolithic to the present day.

Raw earth is also a safe material: in case of fire, in fact, it undergoes a firing process without combustion. Moreover, for centuries it has also been used in zones with a high seismic risk, where man has developed specific constructive cultures with particular technical solutions capable to withstand to the seismic action (Baglioni, Jorquera, 2012).

Applications in contemporary architecture

In Italy, an increasing number of designers are approaching sustainable architecture and the applications of earth material, but the market is still struggling to take off and the new realizations are limited, or do not include all the possible uses of this beautiful material.

Among the examples of contemporary architecture in which the raw earth was used for the walls we can mention the following:

- 1 "La Raia" winery, in Piedmont, building with rammed earth walls utilizing local earths, which contribute to maintaining the right microclimate for the conservation of wines (<http://www.la-raia.it/azienda-agricola-biodinamica/cantina-in-pise>);
- 2 a private house in Tuscany (Fig. 3), near Amiata Mount, also built according to the rammed earth technique with the use of local earth (<https://www.archilovers.com/projects/80394/pise-house.html>);
- 3 the "Panta Rei" environmental education centre, where many sustainable building techniques have been used - utilizing different materials - including some walls in raw earth blocks (or mud brick) and others in lightened earth (Fig. 4) - that is a filling of straw and slurry on a wooden structure (<https://economiecircolare.com/atlante/panta-rei>);
- 4 the "Vigilius Mountain Resort" in South Tyrol where partition walls in rammed earth have been used inside the bedrooms in order to separate the sleeping area from the toilet area (<https://www.vigilius.it/it>).



Fig. 3 Rammed earth house in Tuscany (by E. Baglioni, 2013)



Fig. 4 Lightened earth wall with clay plaster in Panta Rei (by E. Baglioni, 2008)

Although the earth has been used since ancient times as a building material for the construction of load-bearing walls, currently in Italy and in other European countries it is possible to use earth only for curtain walls or partitions, combined with a preferably wooden bearing structure, but also metal or reinforced concrete.

The few realizations of earthen masonries probably depend on the need, especially for some techniques such as rammed earth or cob, of a lot of manpower and therefore to the relative high costs, in addition to building and drying times longer than many other materials.

Another aspect is related to the common way of thinking that prefers less performing materials in comparison with raw earth - from the point of view of sustainability and the healthiness of buildings -, but considered more "safer" just because widely used in the last 70 years. Finally, the raw earth, having been for millennia linked to the craftsmanship and building ability of the human being, suffers from a prejudice in our time increasingly linked to industrialization.

Products in raw earth

An increasing number of companies are moving towards the production of green building products with the aim of bringing sustainability linked to the certification and technical classification of building materials to the construction market. Among these, there are those in raw earth such as solid and perforated blocks, slabs, mortars, premixed for rammed earth, plaster and finishes of walls and floors in various colours. Below are some Italian companies involved in these activities:

1. Matteo Brioni (<https://matteobrioni.com/>);
2. Terracuda (<https://www.terracruzitalia.com/it>);
3. Terragena (<https://www.terrarena.it/>);
4. Ton Gruppe (<http://ton-gruppe.it>).

Finishes in raw earth

The most widespread application of raw earth in Italian contemporary construction is certainly that of plasters and finishes in "clay", which are applied not only on earthen walls, but also on walls made with other materials, both bio-ecological and conventional. The greater use of this solution is certainly linked to the fact that the plasters can also be used in renovations and not necessarily in new buildings. Clay plaster is chosen both for its performances linked to the hygrometric regulation - which can be perceived starting from thicknesses of at least 3 cm -, and for the aesthetic aspect linked to the texture, colours and physical and emotional sensations that evokes. Fig. 5 shows an example of beautiful creations with precious artistic clay plasters that appear to be real works of art (<http://www.isabellabreda.it/>).

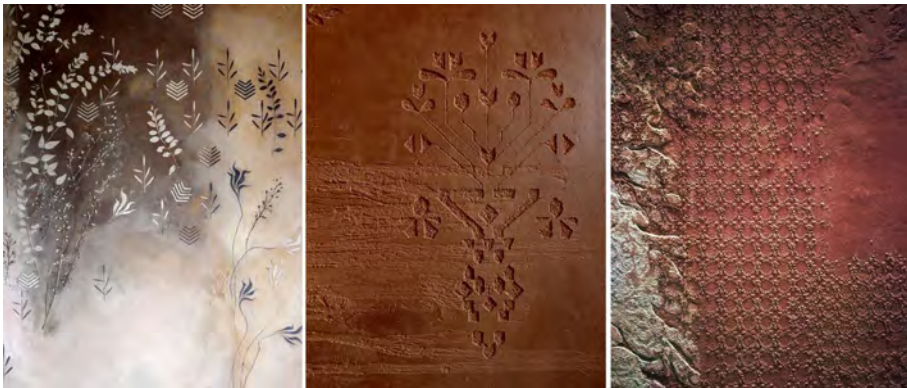

Fig. 5 Artistic clay plasters realized by the architect and artisan Isabella Breda, Italy
(by I, Breda, 2018)

Furnishings and Design

The raw earth use is gradually growing also in the field of interior decorations such as tables, lamps, benches or furniture that, thanks to the plasticity of the material end

therefore to the possibility to model it, can also merge and be incorporated with the walls themselves. Examples are those of the group of craftsmen Geologika Collective (<http://www.botteghedinterni.com/frigerio/>). In addition, starting from some years ago, a competition has been launched for the design and realization of earth-based design works, the Terra Migaki Design Competition (<https://terramigakidesign2020.myportfolio.com/>).

Taking advantage of the thermal inertia property, raw earth is often used to make heat storage stoves inside houses, or ovens for baking bread or pizza, installed both inside and outside the buildings. Worthy of note are the stoves produced by Filo di Paglia (<http://www.filodipaglia.it/filodifuoco>), and the ovens made by Andrea Magnolini (<https://www.passileggerisullaterra.it/forni-in-terra-cruada/>).

Building and auto-construction

The raw earth, due to being a natural material, easily available, malleable and potentially usable by everyone - adults and children -, lends itself - and is often used - to self-construction.

If self-construction applied to small artefacts such as furnishing accessories or ovens is acceptable, a more complex situation is the self-construction of entire walls, or even complete constructions. In that sense, in order to realize buildings that are not only aesthetically pleasing and comfortable, but also stable, durable and safe, self-construction is advisable only if assisted and guided by professionals and technicians of the sector, who have expertise about the structural aspects, normative, and about the particular building technique chosen for the project.

From a normative point of view, self-construction in Italy is not fully regulated and it is frequent that the new realized buildings, if they have not been accompanied by experts, do not fulfil the required quality and standards, despite being pleasant, welcoming and creatives from an aesthetic point of view.

The raw earth, therefore, if on the one hand lends to self-construction thanks to its simplicity of workability, on the other hand it requires, like any other material, numerous technical skills in order to better manage its strengths, weaknesses and variability.

The new experiments

The last frontier in the use of raw earth is the 3D printing of entire houses. An entirely Italian project, Wasp, has in recent years created a giant 3D printer and developed an earthen mixtures suitable for this use, being able to realize "Gaia", the first prototype of earthen building in realized with a 3D printer (<https://www.3dwasp.com/casa-stampata-in-3d-gaia/>) and Tecla, a circular house build with local, reusable and recycling materials (<https://www.3dwasp.com/casa-stampata-in-3d-tecla/>).

CONCLUSIONS

Taking into account what has been described, it is evident that the raw earth offers, thanks to its versatility and variability, the possibility to use many different construction techniques and shaping infinite architectural forms, both enhancing the local traditional building know-how and stimulating the design of new techniques and solutions.

Furthermore, its multiple technical properties make the earth a competitive material in comparison to others present on the building market and offers a great benefit in terms of human well-being, healthiness of buildings and low environmental impact.

The hope is certainly that its use could increase, as it is the case of other countries (Rael, 2009; Gauzin-Muller, 2016) where this material has never been abandoned, or where it has been regulated, thus increasing its potential for use.

BIBLIOGRAPHICAL REFERENCES

- AA. VV. (2008). *Mon Cru - il patrimonio in terra cruda dell'astigiano*, Piemonte, Italy: Provincia di Asti, Regione Piemonte.
- AA. VV. (2012). *Earth/Lands Earthen Architecture in Southern Italy / Architettura in Terra nell'Italia del Sud*. Pisa, Italy: Edizioni ETS.
- AA.VV. (1998), *Dalla terra la casa: il Borgo di Villa Ficana*, Macerata, Italy.
- Achenza M., Atzeni C., Mocci S., Sanna U. (2008), *Il manuale tematico della terra cruda in Sardegna*, Cagliari, Italy: Regione Autonoma della Sardegna.
- Baglioni E. (2016), *Patrimonio costruito in terra en la Región Umbria (Italia)*, poster at "Terra 2016. XIth World Congress on Earthen Architectures", 11-14 Giugno 2016, Lione, France. Published by Craterre at https://craterre.hypotheses.org/1145/attachment/137?lang=en_GB.
- Baglioni E., Jorquera S.N. (2012), "Cobquecura, a southern earthen chilean town: intervention criteria for the reconstruction after chilean 2010 earthquake". In *Rammed Earth Conservation*, Londra, England: CRC Press.
- Bertagnin M. (1998). *Architetture di terra in Italia. Tipologie, tecnologie e culture costruttive*, Monfalcone, Italy: Edicom Edizioni.
- Bollini G. (2013). *Terra battuta. Tecnica costruttiva e recupero. Linee guida per la procedura di intervento*. Gorizia, Italy: Edicom Edizioni.
- Cavalcanti O., Chimirri R. (1999), *Di fango, di paglia... Architettura in terra cruda in Calabria*, Soveria Mannelli, Italy: Rubettino Editore.
- Conti A.P. (2004), *Villa Ficana, an earthen quarter in the town of Macerata, Italy*, Proceedings of Lehm 2004 Congress.
- Conti G. et al. (2004). *Viaggio nella terra cruda in Italia - antologia della terra cruda 1997-2004*, Chieti, Italy: Editrice Tinari.
- Gauzin-Muller D. (2016), *Architecture en terre d'aujourd'hui*, Craterre Editions, Museo Editions, Amaco.

- Mattone R., Mattone M., Robboni C. (2010), *Il paesaggio delle case in terra cruda (Piemonte)*, Cuneo, Italy: L'Artistica Editrice and Regione Piemonte.
- Rael R. (2009), *Earth Architecture*, New York, USA: Princeton Architectural Press
- Rasicci P. (2007), *Casa di terra del Medio Adriatico*, Colonnella, Italy: Marte Editoria.
- Tomasi M. (2012). *Valutazioni ambientali mediante Life Cycle Assessment (LCA) sui mattoni in terra cruda: il caso studio di Pabillonis*. Tesi di laurea, Università degli Studi di Bologna, Italy.

WEB SITES

Accessed on 05 May 2021

- <http://www.anab.it/>
- <http://casediterra.com>
- <https://economiecircolare.com/atlante/panta-rei/>
- <https://matteobrioni.com/>
- <https://terramigakidesign2020.myportfolio.com/>
- <http://ton-gruppe.it>
- <https://www.archilovers.com/projects/212497/la-casa-di-teresa.html>
- <https://www.archilovers.com/projects/80394/pise-house.html>
- <http://www.botteghedinterni.com/frigerio/>
- <https://www.ecomuseoficana.it>
- <http://www.filodipaglia.it/filodifuoco>
- <http://www.isabellabreda.it/>
- <http://www.la-raia.it/azienda-agricola-biodinamica/cantina-in-pise>
- <https://www.passileggerisullaterra.it/forni-in-terra-cruda/>
- <http://www.terracruda.org>
- <https://www.terracrudaitalia.com/it>
- <https://www.terragera.it/>
- <http://www.ventanas.it>
- <https://www.vigilius.it/it>
- <https://www.3dwasp.com/casa-stampata-in-3d-gaia/>
- <https://www.3dwasp.com/casa-stampata-in-3d-tecla/>



EARTHEN 3D PRINTED CONSTRUCTIONS TOWARDS A NEW HIGH-EFFICIENT WAY OF BUILDING

MASSIMO MORETTI - ALBERTO CHIUSOLI - LAPO NALDONI - FRANCESCO
DE FABRITIIS - MASSIMO VISONA'

WASP s.r.l. - Via Castelletto, 104/106, 48024 Massa Lombarda RA - Italy

Keywords: 3D printing, 3D printed house, Crane WASP, Big Delta WASP, maker economy starter kit

INTRODUCTION

The WASP¹ project, whose name takes inspiration from the potter wasp², was born with the goal of preserving the world environmental conditions from demographic growth, employing raw earth and available resources such as the insect does by building its own nest. This approach is substantial in planning off-grid construction, by just exploiting local materials reducing the environmental impact as well as advancing the human opportunities by spreading useful technologies. A new development model is needed to restore the increasing impoverishment without overcharging the global system, by holding the power of shared knowledge as well as the role of machines in human development. For this reason WASP focused its mission on additive manufacturing as a way to offer equal chances to people in creating products, by easily satisfying their needs and triggering economies from the bottom.

In the last five years, the 3D printing technology is raising its constructive application thanks to a substantial improvement in the fields of materials science, robotic kinematics, and building design.

1 WASP (World Advanced Saving Project) c/o CSP s.r.l. is a leading company in the 3D printers manufacturing. It is based in Massa Lombarda (RA), Italy, since 2012. Website: www.3dwasp.com.

2 Potter Wasps are a subfamily of vespids, known for the shape of their nest made in most cases with mud.

This tendency has been promoted by the increasing interest in architecture generated by digital design as well as digital manufacturing, taking advantage from the numerical control in the construction phases in terms of efficiency and high-precision.

The company WASP has taken part in this radical building shift since 2015, with Big Delta WASP 12 mt, considered the world's largest 3D printer ever realized. The experimentations led through this machine enabled advancing the 3D technology to a new modular system, called Crane WASP (2018), which allows larger extensions thanks to different configurations. In this regard, the Crane WASP represents a new way to print on-site, optimizing the building yard management thanks to multiple units, a radical progress from the earlier technology that might change how buildings will be constructed.

THE CONTRIBUTION OF CRANE WASP TECHNOLOGY IN THE 3D PRINTING INDUSTRY

The Crane WASP (Fig. 1) is a modular collaborative 3D printing system, which reinterprets the classic building cranes from a digital manufacturing point of view. It consists of printer units that can be assembled in different configurations depending on the printing area and therefore on the dimensions of the architectural structure. The printing area of the single module is a cylinder 3 m high with a diameter of 6,60 m.



Fig. 1 Crane WASP during the construction of Gaia house, Massa Lombarda, Italy, 2018

The 3D printer unit (Fig. 2) consists of a truss column and a radial horizontal truss element, which can rotate around the vertical axis thanks to a support designed to be assembled directly on standard truss pieces.

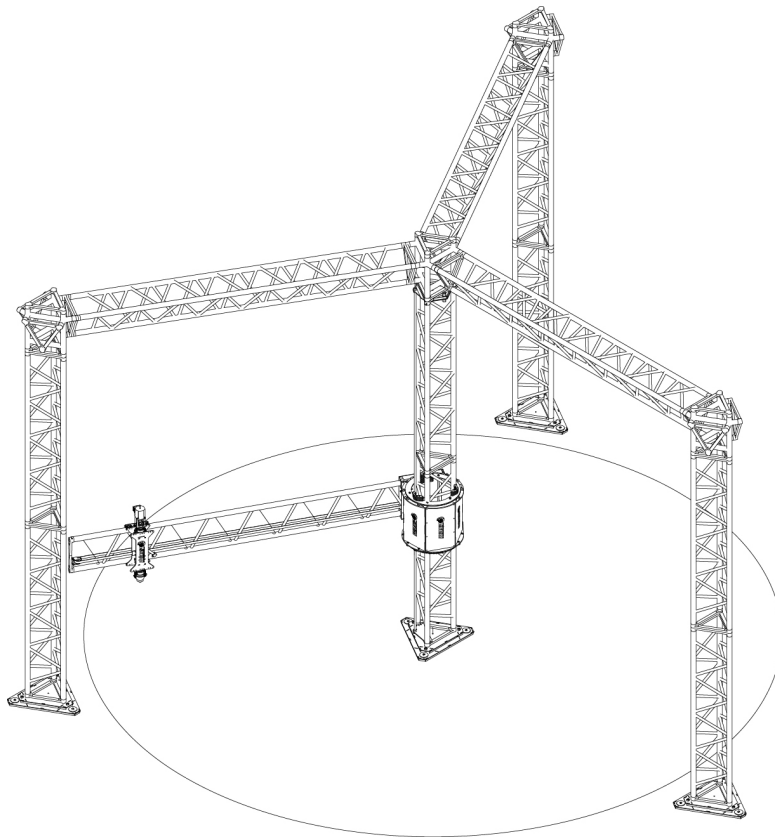

Fig. 2 Crane WASP, technical drawing by WASP, 2018

A five-way truss joint allows setting more elements to extend the upper grid and therefore to install further printers. The modular system may host multiple constructive units that can work simultaneously on the same building, according to the planning of the hexagonal grid. It represents the network of different printers and performs as a framework useful for the management of construction yards, offering support for both the fabric roof and systems.

DESIGN PROCESSES IN PRINTING CODIFICATION

The design plays a fundamental role in the 3D printing process in light of the potentialities offered by CAD/CAM software as well as the increasing request of tailored architectural models. This led to a progressive improvement into digital strategies addressed to 3D modeling and slicing process, in order to match the hardware

needs. The necessity to engage in a dialogue between 3D printing machinery and CAD software allows envisioning the construction as a result of layers' stratification.

Therefore, the computational design is involved in the geometry interpolation in order to reach full control of linear movements as well as to achieve local variation in extrusion parameters. The mentioned research takes an active part in the management of toolpath³ by supervising via software each control point, including positioning and extrusion data. The 3D printed constructions will be designed ever closer to machine language, to come across the real execution processes, enhancing the awareness of technological background as well as the architectural outcome. Currently, the research of WASP is undergoing to further development among digital toolpath-based strategies (Fig. 3), by defining complex woven paths able to confer mechanical strength and static reliability to the printed walls as well to optimize the use of material in the constructions.

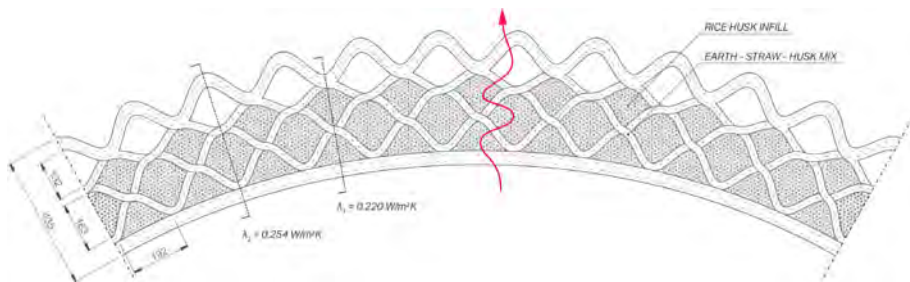

Fig. 3 3D printing toolpath in earthen wall section by WASP, 2018

EARTHEN MIXTURES APPLIED TO THE BUILDING PROCESS

The establishment of the 3D printing industry in the architectural field has implied the raising production of construction materials developed on purpose for LDM⁴ extrusion with predefined settings of rheology and viscosity. The cementitious mortars are the most frequently used materials in the 3D printing state of the art, because of the current knowledge about concrete and admixtures. Furthermore, additive manufacturing allows optimizing structures according to the operating loads and ensures to save material compared with the ordinary elements, meeting the present needs of civil engineering.

- 3 The path through space that the nozzle follows on its way to producing the desired geometry of the workpiece.
- 4 LDM (Liquid Deposition Modeling) refers to the technique of extruding fluid-dense materials, such as clay or cement based mixtures.

WASP, since its first experimentations, has been aware of the role of 3D printing towards new architectural scenarios, by glimpsing, however, on natural materials the way of promoting on-site constructions. The company used the raw earth as construction material aimed to minimize the environmental impact as well as promoting circular economy processes. The construction is conceived as a way to exploit raw materials, available on site, and advance them thanks to mixing machinery.

For instance, the earth addressed to 3D printing technology needs fibres to avoid shrinkage during the drying process once printed. This necessity gives the opportunity of recycling waste materials, derived from the agricultural chain, and triggering the local existing economies for on-site constructions.

The earthen mixture becomes a real fiber-reinforced material, lighter and more insulating than the only soil, suitable for a cladding system.

The mixture printed weighs about 1400-1500 kg/m³ and, despite its low-cost, performs as a multi-purpose material. A new kind of mono-material cladding (Fig. 4) might make the present multi-layered building envelope turn into a fully integrated earth wall, able to fit the climate conditions.



Fig. 4 Earthen mixture in 3D printing process, Gaia house, 2018

CONTINUOUS MATERIAL FEEDING SYSTEM

The 3D printing technology, as a complex system of material processing, needs to keep the physical parameters of earth within a specific range of workability, according to the characteristics of all the machinery employed from the matter supplied until the extrusion.

Firstly, the dry earth needs to undergo a phase of filtering with a rotary screen, discarding stones larger than 4 mm; once it has been obtained, it has to be mixed with water (42 l per 100 kg of dry earth) and raw fibers inside the wet pan mill. This machine allows getting a homogeneous and well-kneaded mixture that is ready to be used for construction almost in an hour. Through a mortar pump, the earth mixture is pumped at 5-10 bar of pressure until the extruder inlet, providing a continuous and controlled amount of matter. Thanks to specific pressure sensors the extruding flow is detected to keep constant at 2 bar, by simultaneously managing the rate of pump engine. The deposition happens through a helicoidal screw, which transports as well homogenizes matter until a conical nozzle.

Earth is advanced in each phase (Fig. 5), transforming from an amorphous matter into an informed deposited material, changing its viscosity as well its form.

The entire mentioned material processing employs ordinary machines, customized for 3D printing in order to become an equipment exportable all over the world with the Maker Economy Starter Kit⁵.



Fig. 5 Diagram of material feeding system by WASP, 2018

GAIA, THE FIRST CASE STUDY OF 3D PRINTED EARTH HOUSE

Gaia house has been realized in August 2018 using Crane WASP and represents the first case study of 3D printed construction using earth-based material. The natural mixture employed for the wall realization consists of a soil (30% clay, 40% silt, 30% sand), on site excavated, and rice cultivation waste materials, such as chopped rice

⁵ The container that permits shipping all the machinery needed to establish a construction site with 3D printing technology.

straw and rice husk. Thanks to the technical consultancy of RiceHouse⁶, it was possible to improve a material compound based on the need of 3D technology. Thus, 3D printing becomes an alternative approach of recycling agricultural waste products in a high-efficient way, by generating new purposes of earth and vegetable fibres in the building industry.

Concerning the realization of the project, to print the wall it took 100 hours for the production and 9 m³ of materials; the extruding rate has been about 90 l/h. At this regard, current rice cultivation data permits to conceive one hectare of cultivated paddy field as a natural supplier of 100 m² of built area.

The walls (Fig. 6) consist of seven printed shells for an overall 40 cm thickness and have been designed with the aim of embedding natural ventilation and thermo-acoustic insulation within the building envelope.

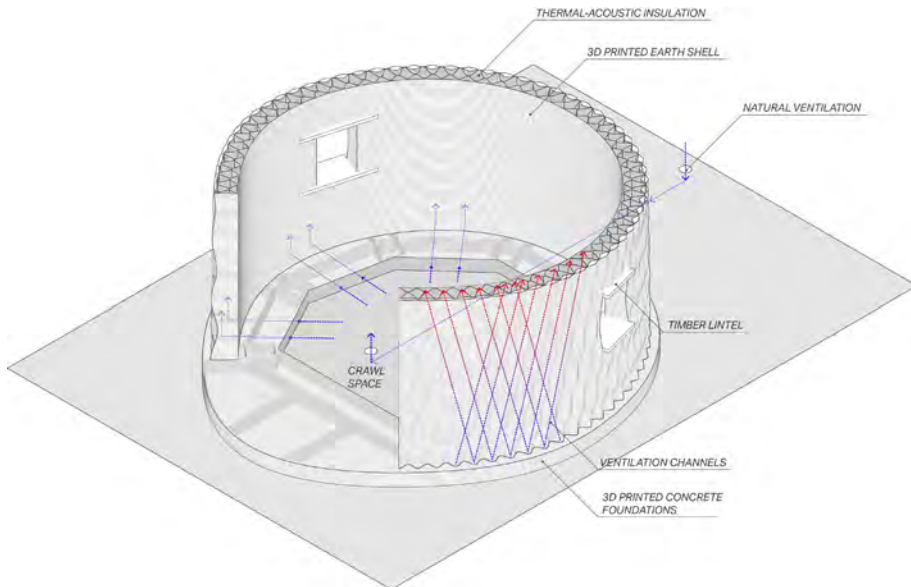

Fig. 6 Building envelope of Gaia by WASP, 2018

As regards the wall thermal performances, the U-value has been certificated to 0,249 W/m²K, as result of 20 cm of rice husk insulation inside the internal cavities.

The design of wall toolpaths is based on sinusoidal mathematical function, able to stiffen the wall surface and interlock the different shells at the same time. Openings have been set by positioning timber lintels during the printing process, allowing the installation of ordinary square windows. The roof stands upon a timber frame

⁶ RiceHouse s.r.l. is an Italian start-up focused on the use of rice waste materials in the green-building industry. It is based in Andorno Micca (BI), Italy. Website: www.ricehouse.it

structure, fixed to the concrete foundations so as to comply with current constructions standards.

Certified to be at the highest energy class, the project (Fig. 7) represents a significant achievement for 3D printing technology because offers new scenarios of building sustainable construction, taking advantages from the additive manufacturing, both in terms of feasibility and replicability.



Fig. 7 Gaia house, external view, Massa Lombarda, Italy, 2018

CONCLUSIONS

The 3D printing technology is already an integral part of new construction scenarios and the research led by WASP focuses on the contribution that Crane WASP might offer in several viable aspects for future architecture:

- Promotion of the human and material resources from the territory;
- Digitalization of construction project, from the design process to the site;
- Recycling natural waste from the agricultural chain;
- Sustainability of construction process with low environmental impact;
- Achievement of multi-purposes construction.

The current aim of the company is to make the 3D printing process as affordable as possible to easily set on-site low-cost constructions in countries of Third World, generating social and living opportunities for populations. WASP is aware of the impact of earthen 3D printed construction, especially if addressed to trigger progress and struggle poverty conditions thanks to innovative technologies; therefore new manufacturing phases will be undertaken for the future of the building industry.

In this context Gaia experience (Fig. 8) offers the opportunity to divulge the multiple potential that 3D printing can express thanks to the world agricultural resources, guaranteeing a minimum environmental impact in addition to infinite design solutions, essential in a new living frontier vision.



Fig. 8 Gaia house, internal view, Massa Lombarda, Italy, 2018

BIBLIOGRAPHICAL REFERENCES

- Institute for Advanced Architecture of Catalonia (IAAC) Open Thesis Fabrication - Digital Adobe (2018), <http://www.iaacblog.com/programs/digital-adobe-additive-manufacturing-adobe-towards-passive-habitats/>.
- Marta Malé-Alemany and Jordi Portell (2017), FABbots: Research in Additive Manufacturing for Architecture in Fabricate 2014, Eds by F. Gramazio, M. Kohler, and S. Langenberg, Open Access.



RESEARCH AND PRACTICE OF CONTEMPORARY EARTHEN ARCHITECTURE

MU JUN¹, ZHOU TIEGANG², JIANG WEI¹

¹ Beijing University of Civil Engineering and Technology - BUCEA, Beijing, China

² Xi'an University of Architecture and Technology – XUAUT, Xi'an, Chinataly

Keywords: Earth Architecture, Rammed Earth, Rural Construction

INTRODUCTION

The tradition of building with earth-based materials is widely distributed over China. According to the latest statistics (NBSPRC 2012), at least 60 million people in China are still living in traditional earthen dwellings, most of which are located in poor and rural regions (Fig. 1). Since their shortcomings in mechanical and waterproofing performance can not satisfy gradually diversified demands for rural living, traditional earth-based technologies have been usually regarded as a symbol of “poverty” and “dangerous” by dwellers and governments, and an increasing number of rammed-earth dwellings have been abandoned and replaced by conventional constructions with concrete and bricks. However, the actual result is that most of renewed “dangerous” dwellings become more dangerous and energy-inefficient, since the only affordable and self-operated way for most poor villagers is to simply “combine” concrete-based techniques with their original building system.

Research and practice of the team in earth architecture date back to 2004. Supported by the Ministry of Housing and Urban-rural Development (MOHURD) and Wu Zhi Qiao (Bridge to China) Charitable Foundation (WZQCF), in the past 14 years the team carried out a series of projects over the whole country (Fig. 2), aiming to explore a feasible way towards ecological architecture by utilizing earth-based resources and traditional construction wisdoms. During the process, what the team experiences in earth architecture could be classified into three phases: exploration and application of eco-potentials of traditional earth tech, anti-seismic design and improvement of traditional structure system, and innovation of earth-architecture-system based on material sciences.

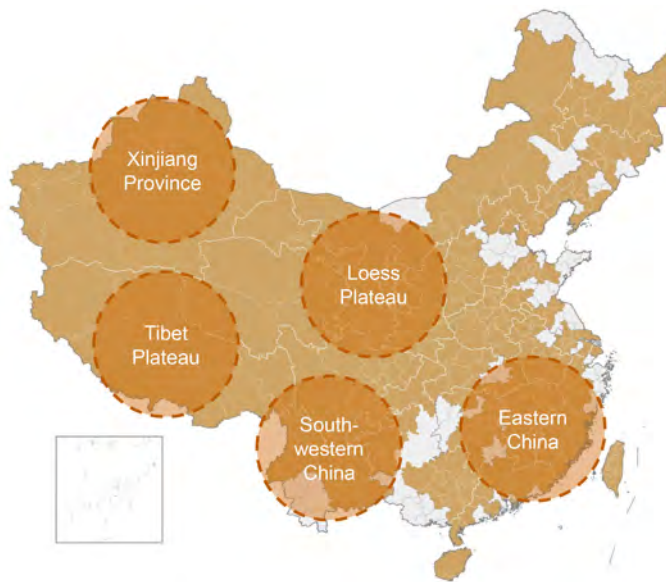

Fig. 1 Distribution of traditional earth dwellings in China



Fig. 2 Distribution of team's practices of earth architecture in China

EXPLORATION AND APPLICATION OF ECO-POTENTIALS OF TRADITIONAL EARTH TECH

Under the poor conditions of China's Loess Plateau region, the feasibility limited by budget and conventional resources is the main challenge faced by ecological design for local buildings. In this context, the eco-school project in the Maosi village is initiated as a prototype, aiming not only to educate the locals about how a "good" village

school should be but also to explore a way towards an ecological architecture suited for this region. As a charity project, the design team is responsible not only for design, but also for raising funds and organisation of construction.

The project emphasizes a scientific and transferable methodology combining three phases: condition analyses, computer simulation experiments and field construction. Condition analyses in economy & resource for building, climate, and vernacular architecture deduce that thermal design for this region is the most effective approach forwards ecological architecture, and both design and construction should follow the principles: comfortable indoor ambience, cost-effectiveness, minimum embodied energy in buildings and construction ease. The outcome is further promoted by a series of thermal simulation experiments with the software of TAS (EDSL) for classroom model. By filtering and optimizing locally available materials and techniques in eco-system and vernacular earth architecture, it is found that the most basic technique, thermal mass and insulation based on earth and other natural materials, are the most effective solution in sustainability and practical feasibility, and hence should be employed as the key strategy in classroom design.

Following the original topography, 10 proposed classrooms are planed into 5 units at two levels for maximum exposure to daylight and natural ventilation in summer. Tree-based landscape helps to create a desirable campus ambience for children. The classroom form is derived from local traditional houses with timber structure so as to be constructed easily by villagers. Thermal mass and insulation are employed in forms of mud-brick walls, the insulated traditional roof, double-glazed windows, etc. The semi-buried form at the north side together with the direct-gain mode of passive solar system can further upgrade the thermal performance. Daylight to the indoor space is also maximised by some special treatments, such as angled opening of some windows. (Fig. 3, Figg. 4a-4b)



Fig. 3 Overview of Maosi Ecological School



a



b

Fig. 4 a-b Partial view of the school campus

The construction inherited the local traditional means. It was implemented by the villagers themselves mostly with simple traditional tools. Most building materials, such as mud bricks, rubble, straw and reed, are sourced inside or around the site with minimum embodied energy. Also due to the involvement of these natural materials, during construction little waste was generated, and most of waste and left construction materials are recycled back to construction, such as the waste rafter and purlin reused for children's facilities, waste mud bricks mixed to the straw mud for plaster, etc. All of these treatments are greatly helpful not only to maximise the absorption of local folk traditional wisdom, but also to minimise energy consumption and environmental impact caused by construction. (Fig. 5)



Fig. 5 Local traditional adobe-based technology was involved in architectural design

The construction of the new school was basically completed in summer 2007. The direct construction cost for materials, equipment and manpower is just around 52EUR/m², far cheaper than local conventional classrooms made of bricks and concrete. The new school has been used by children and teachers since September, 2007. According to field measurement of the last year, it is obvious that the indoor air temperature of new classrooms is always stable, cool in summer and warm in winter.

Even in the last winter cold infrequently, the indoor ambience could still reach an acceptable thermal comfort with fresh air, without burning any piece of coal for heating.

As conclusion, at least three points have been reached by this project. Firstly, the new school creates a comfortable and desirable campus ambience for the children. Furthermore, compared to local conventional schools, during its whole life cycle it contributes a far better ecological performance in indoor comfort, energy consumption and environmental impact. Secondly, as a charity project, besides the school itself most parts of the donation were shared by the village community, due to the employment of local villagers. The last more important one, from the eco-school project the villagers can re-understand their own tradition. The school illustrates to the locals a feasible way towards an ecological architecture suited for the conditions of China's Loess Plateau region. In this way, by selectively employing their familiar techniques and materials they can easily build themselves their most effective and affordable ecological approaches. A full report of this project was also completed for future publication. Our work still keeps on going, not only for one school, but also for more feasible demonstration for the whole region.

Last but not least, quoting the school master, "from now on, not one piece of coal needs to be burned to keep warm. All our money can be spent on books."

ANTI-SEISMIC DESIGN AND IMPROVEMENT OF TRADITIONAL STRUCTURE SYSTEM

In May 2008, an 8.0 Richter magnitude scale earthquake hit Sichuan province of China. More than 60 thousand of people lost their lives, and millions lost their homes. Ma'anqiao is one of the poorest villages in this quake-stricken area. Most of the village houses, represented by the traditional rammed-earth courtyard dwelling, were severely damaged. Limited by local low levels of economy and technology and by the poor conditions in transportation and availability for conventional materials like concrete and bricks, it was difficult and unaffordable for villagers to rebuild their homes in conventional construction way. (Figg. 6a-6b)

As these challenges are very typical in the entire rural Southwestern China, supported by Ministry of Housing and Urban-Rural Development of China (MOHURD), a post-quake village rebuild demonstration project was launched by a university-based joint team with a prototype of Ma'anqiao Village in Oct 2008. It aims to demonstrate and convey an affordable, ecological, sustainable, healthy and humane way of rebuilding post-quake village that local villagers could afford, own and pass on.

In response to the challenges and issues the villagers have to face, for villagers' home rebuilding it should be the most efficient and ecological way to selectively inherit and improve their earth-based construction tradition by utilizing locally available resources. It relies on whether suitable technical solutions could be found to restore villagers' confidence in anti-seismic performance of rammed-earth architecture.



Fig. 6 a-b Local traditional rammed-earth courtyard dwellings and damaged houses after the earthquake

According to our investigation and field study, the answer is definitely yes. Therefore, the basic strategy for study and practice of the project should focus on the following two aspects. Based on local natural materials and wastes from collapsed buildings, one consideration is to improve local earth-based architectural technology and design so as to upgrade their security of construction and living environment. The other is to guide and train villagers with enhanced earth-based technology, and facility them rebuilding their own homes according to their economical ability and demands. During the process, the working motto of “high science and low technology” needs to be followed both by employing the scientific research methods and tools, and by demonstrating and conveying a cost efficient, ecological, feasible, healthy and humane way of post-quake village rebuild that local villagers could afford, own and pass on.

By integrating the above analyses and the local post-quake situation, the action plan of the demonstration project was proposed and implemented in three phases: prototype-based demonstration and training to local villagers; local extension and home rebuilding; technique promoting and regional training and extension.

Firstly, facing those post-quake challenges, the villagers felt restless and confused about how to rebuild their houses. It was imperative to restore their confidence in earth architecture and demonstrate to them how to rebuild their houses with all resources they had in-situ. A rammed-earth courtyard, as a prototype, was therefore constructed by the team and villagers from each family. It provided them with a participative training on the basic techniques which was carried out from the latest researches (Jin-jie and Jia-ping 2006, Tie-gang, Jin et al. 2008), and can effectively enhance the structural stability and anti-seismic performance of their traditional earth houses. (Fig. 7)

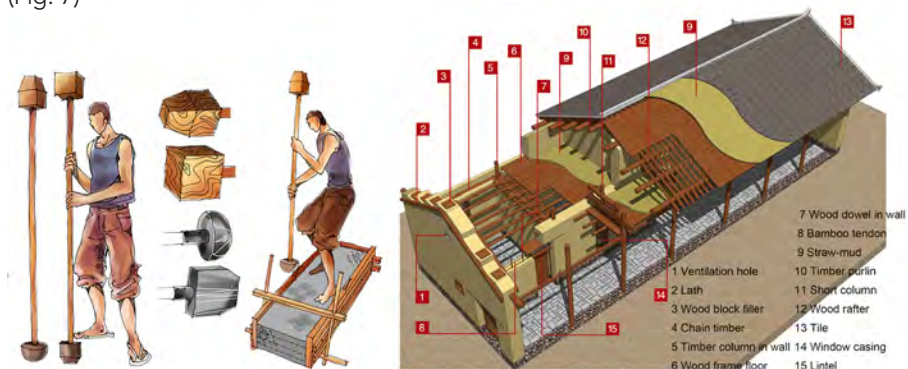

Fig. 7 Optimized structure systems and standardized construction tools based on local tradition in earth dwelling

In the early beginning of the second phase, by utilizing locally available resources a series of on-site experiments were conducted to further optimize those techniques

for a most efficient and affordable solution and easy-to-follow technical guideline to the villagers. Meanwhile, based on the pattern of traditional courtyard with respect for local culture and livelihood, the team also carried out a numbers of design schemes, which can greatly improve their living environment and can selectively be employed in their house rebuilding according to their individual conditions and demands. Equipped with the design reference and techniques they learned in the prototype construction, all 33 families of the village rebuilt their houses by themselves within 3 months. (Fig. 8)



Fig. 8 Prototype construction and technical training to villagers

In the last phase, based on the research result, the team designed and mobilized the villagers to build a village centre to enrich the villagers' public activities and improve their service facilities. It also acts as a demonstration center of anti-seismic rammed-earth building technology. To further promote this method in other earthquake-stricken area in western China, an Anti-seismic Rammed-earth Village House DIY Construction Manual was compiled and published to provide guidance to laymen such as villagers and carpenters on how to build rammed earth village houses which are anti-seismic and economical. By monitoring the construction process and newly-built houses by villagers, a comprehensive evaluation has been conducted.

The upgraded earth-based technology is easy to handle with simple tools so that the house of each family could be rebuilt within 1-2 months by only relying on one or two employed craftsmen and free helps from several neighbours. Over 90% of

materials are “wastes” from damaged buildings and natural products sourced from the village. Therefore, its averaged construction cost is only 15 EUR per square meter, which is one tenth of the one of local newly-built houses with concrete and bricks. Construction of the whole courtyard with living and husbandry spaces can be covered only by the financial support and their savings. Meanwhile, the indoor ambience of the new earth house is far cooler and stabilized than that of the latter. Moreover, energy consumption and CO₂ emission caused by the whole lifecycle of the new rammed earth houses are greatly minimized and hence it shows a far better ecological performance than local conventional buildings. To villagers, their living needs got entirely satisfied with more healthy and comfortable living environment. By now the village has come back to the original peace and harmony.

INNOVATION OF EARTH-ARCHITECTURE-SYSTEM BASED ON MATERIAL SCIENCES

During several catastrophic earthquakes since 2008, a large number of earthen houses were severely damaged made villagers, local governments and even the public deeply disappointed about the weak anti-seismic performance of the traditional earth-based building. Building with concrete and fired-bricks is always regarded as the only reliable way towards “safety” and “modern” architecture. Consequently, the central government of China, in the past decade, strongly provided those poor rural regions with a series of financial and political supports to renew the millions of “dangerous” earthen dwellings with conventional construction modes by concrete and fired-bricks. However, the actual result is that most of renewed “dangerous” dwellings become more dangerous and energy-inefficient, since the only affordable and self-operated way for most poor villagers is to simply “combine” concrete-based techniques with their original building system.

Under this background, the potentials of the rammed-earth, as a most popular traditional earthen technology in China, got reviewed and verified by related earth-based material science in developed countries. However, limited by the local low levels of education, economy and industry, overseas successful practical experiences can not be directly involved to enhance the mechanical performance of rammed-earth dwellings in rural China. Thus, a localized construction system with rammed-earth, which can build affordable, anti-seismic and ecological architecture, is much needed.

Authorized by MOHURD, in 2011 a demonstration research project was launched by WZQCF with the scientific support from CRATerre-ENSAG. Based on innovation and improvement of traditional rammed-earth technology, it aims to illustrate an affordable, sustainable and ecological way of rural dwelling construction, which could be taken, owned and passed on by villagers in regions with the rammed-earth traditions.

1 Fundamental Research

The demonstration research project was firstly launched in Macha village, Gansu, where the construction tradition with rammed earth has lasted for thousands of years. According to the theory of soil stabilization developed by CRATerre-ENSAG (Houben 1994), the mechanical performance of rammed-earth mass could be greatly enhanced via powerful ramming and gap-graded mixture of clay-sand-gravel with 8-12% of moisture content. The theory was well verified by a series of material experiments with various sample of soil in the region. By giving a ramming force of over 0.5 MPa with the pneumatic hammer, the compressive strength of upgraded rammed-earth mass (40 × 40 × 150 cm) is up to 1.4 MPa averagely, almost twice of the one of local traditional rammed-earth mass (Ying 2012), even close to the one of China’s conventional fired-brick walls.

Encouraged by the material experiment result, a comparative study between upgraded and traditional rammed-earth technology was further developed in order to clarify the key effect factors which influence the performance of rammed-earth. As shown in Table 1, among all factors influencing the construction method and the localization of the upgraded rammed-earth technology, the shuttering system suitable for the use of pneumatic hammers is the biggest challenge in terms of Rural China’s situation and hence should be one of the crucial contents in the coming experimental study.

Table 1 Comparison between upgraded and China’s traditional rammed-earth technology

Effect Factor	China’s Traditional Rammed-earth Technology	Upgraded Rammed-earth Technology
Material	“Clayey” soil Poor mechanical properties of materials and water resistance	Mixture of clay, sand, gravels which improves the mechanical properties of materials and water resistance
Moisture content	5-15%	8-12%
Hammer	Manual Hammer Limited ramming force	Pneumatic /Electrical Hammer Firmier ramming force. It’s available by retrofitting the pneumatic tamper which is conventionally used for mine construction in China
Shuttering system	Rafter/Board Simple but infirm	Flexible and Stronger Shuttering System shuttering system is needed to be against the greater ramming force from pneumatic hammers
Materials Blending	Manual Low efficiency, much manpower	Blender Efficient

Referred from market investigations and several rounds of machining experiments, a set of shuttering systems are developed with bamboo plywood, shape steel and tension screws which are comparatively cheap and available in most of rural markets of China. The system is composed of 9 panels which can be flexibly assembled by only two workers for ramming walls in "I", "L" and "T" forms directly, so as not only to satisfy various rural construction demands, but also to effectively reinforce wall corners mechanically.

There is still no specialized building code for earth-based construction in China. Since Wenchuan earthquake in 2008, the national earthquake resistant code for the rural masonry-structure-dwelling has been upgraded into a higher level. Under this situation, a scientific study on the structure system of the new rammed-earth dwelling should be crucial for future dissemination. Both systems of the traditional rammed-earth building and the masonry structure with codes got seriously reviewed in terms of mechanical properties of the upgraded rammed-earth wall together with the developed construction methods. A series of feasible technical solutions for reinforcing the rammed-earth dwelling are carried out and could be summarized in three aspects: 1) Capping the span, storeys and floor height of the rammed-earth house to reach a reasonable shape coefficient for seismic resistance; 2) involvement of timber-made (or prefabricated concrete) structural columns in wall corners and ring beams (timber or prefabricated concrete) on both top and bottom of earth walls; 3) improving structural measures for joints between walls, roofs and walls, and foundations to further enhance the structural integrity.

In order to further verify the performance of integrated systems, two models (4 by 4 on plan) with two conventional roofing systems (concrete-based flat roof and timber-based sloping roof) were built for shaking-table experiments. The shaking simulation result shows that the two systems work well and reach the demand for 8.5 degree seismic fortification intensity of China. According to further calculation and analyses, it is verified that in terms of the anti-seismic performance the rammed-earth dwelling (load bearing rammed-earth walls, less than 3-story high) with well-designed structure system works well in most regions of China.

2 Demonstration Construction

A new rammed-earth courtyard for an old couple, as a prototype, was constructed by the local masons and villagers under on-site guidance from the team. The project provided them with a participative training on the basic techniques from previous studies, so that they could directly feel the new construction and further understand how to build their new houses by themselves. During the process, all research products and construction experiences got further consolidated by the team in the form of an easy-to-follow technical guideline to the villagers. With respect for local culture and livelihood, the team studied the traditional pattern of courtyard and carried out a number of design schemes, which can greatly improve their living environment and

can be applied selectively in their house rebuilding according to their individual conditions and demands. (Fig. 9)



Fig. 9 The first rammed-earth prototype built in the Macha village

Convinced by the good performance of prototype construction, all of 12 families in Macha village, who were proposed to renew their houses in 2013, decided to utilize the new rammed-earth technology. Equipped with the guidelines, design schemes, and more importantly the experiences from prototype construction, the families completed their own construction in three months. During the process, there was a big surprise that villagers showed a lot of their creativities and wisdoms in design and construction. After all they knew best about their lives and demands.

3 DIY Manual and Extension

Based on previous experimental and demonstration studies, a DIY construction manual (Mu Jun 2014) about construction of upgraded rammed-earth dwellings was published in 2014. All related techniques got summarized and illustrated with photos and drawings so as to be easily understood and learnt by rural dwellers and artisans. The book has been distributed by MOHURD to villages and Governments in the regions with the construction tradition of rammed-earth. Meanwhile, with the DIY manual as a guidebook and with the Macha village as a training base, over 400 craftsman in Gansu Province have been well trained till now.

Promoted by MOHURD, more than 10 provincial governments have visited Macha village, and showed strong interest in the upgraded rammed-earth technology. Authorized by MOHURD and invited by those governments, in the past two years over 110 rammed-earth houses (partly as demonstrations) have been built in 10 regions of China. During the process, further localization was carried out, and combined with the developed building technology and local traditions or demands. For each demonstration, normally there are 2 well-trained villagers from Macha village and 1 professional from the team to jointly lead the construction team and give on-site trainings to local villagers. Till now, 23 villagers from Macha village have been well trained as trainers, and their livelihood also got improved by building earth houses.

According to the observation and statistics from those houses built in various provinces, the construction cost of new rammed-earth dwellings is averagely 2/3 of the local conventional houses built with fired-bricks and concrete. If it is built in the

neighborhood assistance mode, the cost is even as low as 1/4. Moreover, the embodied energy and CO₂ emission of the former are only 25% and 20% of the latter respectively. Ecological and economical potentials of upgraded rammed-earth are well illustrated via those cross-regional demonstrative construction. Convinced by the demonstration performance, a growing number of governments or clients show interests in the technology and ask for technical support actively. The cross-regional extension work has also drawn a lot of attention from China's mainstream media.

PRACTICE OF MODERN ARCHITECTURE WITH EARTH

1 Macha Village Community Centre

Like other poor villages in China, Macha has been declining over the years. Most of male adults are working away from the village, leaving their children and fields to women and the old people. Under such a situation of "hollow village", their tradition and the original soul of the village are being lost. In late 2013, cooperated between the team and the villager committee of Macha, a sub-project of village community centre was launched on the site beside the crossroads to all community groups, a sloping wasteland with a good view facing the eastern valley.

In response to villagers' demands, the functions of Chinese medicine clinic, nurse, library, stage, shop and a multi-functional hall are combined and organized with the local traditional concept of "three-section courtyard", so as to provide each functional block with a maximum exposure to daylight, good view towards the east valley, cross-ventilation in summer and protection from cold wind in winter. By following the sloping topography facing the valley, all outdoor and indoor spaces are carefully organized on three levels of terraces. Not only current demands of villagers but also a reasonable flexibility for future sustainable development are carefully considered for each space.

The 0.5-meter-thick rammed-earth wall works well as thermal mass to effectively balance indoor temperature and humidity. Due to its enhanced waterproofing performance, it is not necessary to make plastering on the earth wall surface, so that the special texture of rammed-earth can be felt and touched, and can express its natural language. A series of upgraded structures such as roofing and window systems are designed in order not only to realize corresponding functions, but also to work as a further demonstration for both craftsmen and professionals. The upgraded rammed-earth technology got further developed with architectural design in order to provide better spatial experiences. The local tradition of rainwater collection got inherited and further promoted with a roof-ground-based system. The valley wind resource is utilized with a wind turbine system, and can cover the daily demands for electricity.

By two summer workshops with totally over 80 student volunteers and 30 villagers involved, the center got constructed and started to operate in April 2016. The two-year construction worked further as a training and education process for both the

villagers and the involved university students from the Mainland China, Hong Kong and overseas.

The village centre, which is mainly made of on-site resources, is now standing peacefully there, like growing out of the ground. It is working as a community centre as well as a demonstration and training base of MOHURD in upgraded rammed-earth technology. With the DIY manual as a guidebook, over 300 craftsmen from the region have been trained by the team and those well-trained Macha villagers. Based on the centre space, the team has launched a programme to bridge more resources and trainings in agriculture, handicraft, education, etc. to Macha in the various forms of activities so as to reach a sustainable self-promotion and development. (Fig. 10, Fig. 11)



Fig. 10 Overview of Macha village center



Fig. 11 Internal view of Macha village center

In the past year, assisted by a social worker of the team, based on the newly built public space, the original leather-silhouette drama group composed of twelve elders, which dissolved ten years ago, was restored. The 78-year-old doctor of Chinese medicine in Macha is invited to the clinic so as to service villagers with the assistance of his last student, his grandson; a young family came from the city back to the centre and operate the shop with internet resources so as to provide villagers with e-shopping service; children have been used to playing and reading in the library after school; in the multi-functional hall, women enjoy a series of activities organized by themselves every week, such as dancing, embroidery games and movie playing..... as an elder said, the original soul of Macha seems to be coming back.

2 Commercial Projects with the Developed Rammed Earth Technology

When asking villagers for their feeling about the developed rammed-earth houses, however, sometimes the team got an answer like "It is very strong and comfortable, but it looks still 'earthy'....." In their mind, their traditions always seem like what the poor has to enjoy. Further studies and demonstrations are needed so as to showcase what earth architecture and rural living modes could be in future. Among those, what is happening in urban construction is always most powerful to change villagers' mind. While assisting villagers in improving their earth dwellings for better performance, the team put much energy into combination between research outputs and practices with earth construction, especially following the marketing way.

The rammed earth landscape project for Vanke Daminggong real estate is a significant sample and chance in which rammed-earth, as a developed traditional construction technology, was first involved into the commercial project of modern architecture. The project was led by one of best design institutes, Beijing Institute of Architectural Design. The team is responsible for detailed design of the rammed-earth walls and technical training of rammed-earth construction. The advanced form-work system made of aluminium-magnesium alloy was employed during construction with 20 Macha trained villagers involved. The landscape construction was completed in late 2015. (Fig. 12)



Fig. 12 Vanke landscape project based on developed rammed-earth technology

National Agora Museum of Luoyang Erlitou, as the second earth-based commercial project of the team, is being under construction after almost one year of structural design and experimental research. The museum is as big as 30,000m². Most of walls are made of rammed-earth. The highest earth wall reaches 13 m. A series of corresponding structural details and construction methods have been developed and implemented. The construction was completed at the end of 2019, this museum could be the biggest contemporary earth building of the world. (Fig. 13)



Fig. 13 View of National Agora Museum of Luoyang Erlitou

CONCLUSION

Today, with more and more demonstrative earth-based projects contributed by professionals, wider promotion made by media and MOHURD and increasing attention paid by China's central government on tradition heritage, it becomes much clearer that the governments, clients, architects and even the whole society of China have been realizing the value of earth architecture and its potentials in sustainable development and cultural heritage. The big concern in people's minds has been changing from "why earth architecture" to "how to do it", which is a positive change occurred more quickly than the team expected 10 years ago.

However, there is still a long way to go. Lots of work is needed to remove the "poverty" symbol from earthen architecture in people's minds. What the team has done just means a starting. In terms of the emerging, various demands from the governments, clients and dwellers for more diversified and flexible earth-based techniques with vernacular or modern concerns, the huge research domain of earth architecture needs more systematic and sustainable studies and practices with more parties involved.

BIBLIOGRAPHICAL REFERENCES

- EDSL. "Environmental Design Solutions Limited." from <http://www.edsl.net/>.
- Houben, H.G., Hubert (1994). *Earth construction: a comprehensive guide*. London, Intermediate Technology Publications.
- Jin-jie, Z.X.-p. M. and S. Q.-x. L. Jia-ping (2006). "Experimental study on seismic performance and shear behavior of rammed-earth wall [J]." in *World Earthquake Engineering 2: 005*, pp. 29-33.
- Mu Jun, Z.T., Wang Shuai, Wang Mengyi (2014). *Construction Manual of Rammed-earth Eco-dwelling*. Beijing, China Architecture & Building Press.
- NBSPRC. (2012). from <http://data.stats.gov.cn/easyquery.htm?cn=C01>.
- Tie-gang, Z., W. Jin, L. Xiao-wen and G. An-li (2008). "Seismic Test Research and Economic Analysis for Xinjiang Suitable Buildings in Villages." in *Earthquake Resistant Engineering and Retrofitting 1: 019*, pp. 87-89.
- Ying, X. (2012). Basic Mechanical Properties Testing of the New Rammed Earth Building Materials and Structural Performance Analysis. Master Degree, Xi'an University of Architecture and Techno.

PART 5

CASE STUDIES



EXPERIMENTAL APPROACHES FOR THE CONSERVATION OF THE RUGUANYAO KILN SITE IN HENAN PROVINCE

JINFENG ZHANG

Chinese Academy of Cultural Heritage - CACH, Beijing, China

Keywords: Ruguanyao kiln site, consolidation, conservation

INTRODUCTION

Ruguanyao kiln site is located in Qingliangsi village of Baofeng city in Henan province on an area of more than 1 million m², and it was used from Song dynasty to Yuan dynasty.

Eight archaeological excavations were carried out from 1987 to 2002 on this site. The areas excavated during the first 5 times were refilled, and the areas excavated in the last 3 times remained open and covered by a shelter building with several windows in every wall (Fig. 1).

Besides a little brick wall and potteries, the kiln site is mostly made up of earth. The main phenomenon of decay is pulverization (Fig. 2) and it is becoming more and more serious over time. In this area, the groundwater is at a depth of 40 m because of the presence of a coal mine that avoid the uprising of the water table; therefore the biological growth has little effect. The shelter prevents the site from rain, wind and most of sunlight. Therefore, the main cause of decay is the moisture absorption and desorption in relation with the daily and annual hydrothermal cycles causing swelling-shrinkage phenomena and consequent pulverization.



Fig. 1 Part of Ruguanyao kiln site excavated inside the shelter in Henan, China



Fig. 2 Pulverization of the earth site: main phenomenon of surface decay

To stop further decay, treatments with consolidants were planned. Therefore, a series of laboratory and field tests were first conducted to ascertain its validity and durability. Because there are not enough experimental standards in the preservation of terracotta artifacts as cultural heritage, related standards in hydraulic engineering, civil engineering, geotechnical engineering, etc. were used as a reference.

MATERIAL AND METHOD

According to existing experience, three types of consolidating materials were selected to compare their performance with respect to their deterioration due to aging: Remmers 300 (Germany), MH (Zhengzhou, China) and TEOS (Beijing, China). Their characteristics are showed in Table 1.

Table 1 Chemical-physical characteristics of consolidants

Consolidant	pH	Density/ $\text{g}\cdot\text{cm}^{-3}$	Surface tension/ $\text{mN}\cdot\text{m}^{-1}$	Curing rate/%	Viscosity/ $\text{mPa}\cdot\text{s}^{-1}$	Volatilization rate/ $\text{mg}\cdot\text{m}^{-2}\cdot\text{h}^{-1}$	VOC/ $\text{g}\cdot\text{L}^{-1}$
Remmers 300	6~7	0.8378	26.04	15.72	1.24	75.51	—
MH	6~7	0.9420	22.88	32.97	0.56	66.98	917
TEOS	6~7	0.8242	27.65	2.26	0.84	78.53	—

Two sets of earthen samples were made: one with a diameter of 100 mm and a height of 120 mm to measure the depth of treatment (Fig. 3), the other with a diameter of 61.8 mm and a height of 20 mm, which is standardized for shear test in hydraulic engineering, civil engineering, geotechnical engineering. Considering the operability and efficiency, a dropper was used as a treatment tool in the laboratory. After the treatment, the samples were placed in an environment with relative humidity of 20% - 30% for one month to cure the applied product.

The performance of the products was evaluated after aging by exposure to different values of relative humidity and temperature through thermo-hygro-metric cycles. The possible negative effects induced by the treatments, such as colour changes, reduction in vapour permeability, etc., were also evaluated.

LABORATORY TEST

1 Consolidation depth

The depth of the consolidation is a crucial factor that determines the effect of conservation. If it is too superficial, there is a serious risk that the consolidated layer will detach from the substrate. The depth of penetration is related both to the characteristics of the earth, in particular to its dimensional distribution, and to the intrinsic properties of the consolidant, such as its viscosity and surface tension.

Taking into account that all three tested materials are hydrophobic, the consolidation depth has been evaluated by measuring the hydrophobicity according to Zhang (2013):

- firstly, a hole with a diameter < 15 mm and depth < 5 mm is made on the central top of the earthen sample of $\varnothing 100$ mm \times 120 mm;
- secondly, drops of consolidation material are put into the hole. During the treatment, the hole must be kept full of consolidation material;
- when the infiltration time of 3 ml of consolidant exceeds 90 s or the visible liquid depth on the outer surface of the sample is more than 10 cm, the whole procedure ends.



Fig. 3 Earthen samples ($\varnothing 100$ mm \times 120 mm) made for the measurements of the treatment depth: a) earthen samples cut into two halves; b) some water is put in one half the upper dry part means that is consolidated, the lower wet part is unconsolidated (left). The right image is after water evaporation.

After 1 month, the earthen samples are cut into two halves (Fig 3a), and then some water is put on one half. The one not reached by the treatment area is wet, while the area reached by the treatment is dry (Fig 3b). The depth of the dry area is the depth of the consolidation.

Concerning the hydrophilic consolidants, the resistance to disintegration is evaluated: the earthen samples are put in water and the depth of the part that does not disintegrate is the penetration depth.

Taking into account the monitoring data of Yang (2012) which show that the variation of temperature and humidity in an earthen material is greater in the first 5 cm of depth, we have established that the depth of penetration of a consolidating treatment should be more of 5 cm. For safety reasons, the accepted value has been set to 8 cm.

Concerning the three tested treatments, all of them showed a penetration depth higher than 10 cm.

2 Colour changes

Usually, the colorimeter is employed to measure the chromatic parameters of the earth, and then the difference between the treated and the untreated samples is calculated to determine if it is acceptable or not. However, the colour of the earth is generally uniform and the grey scale (Fig. 4) is more suitable than colorimeter. Moreover, in case of non-availability of the colorimeter, the grey scale is a cheap and simple method.

When using grey scale, the change in hue, brightness or chroma, whether single or combined, is not evaluated in series. The total chromatic difference between the two samples is the basis of the evaluation. If it is necessary to record the characteristics of colour change in the experiment, appropriate quality terms can be added to the digital rating to record the direction of change of colour difference by describing changes in hue (bluer or greener, etc.) or saturation (lighter or deeper) or brightness (lighter or darker)¹.



Fig. 4 Grayscale for assessing change in colour (from China standards GB 250-2008)

The earth samples of $\varnothing 61.8 \text{ mm} \times 20 \text{ mm}$ were divided into 2 parts with a nick line, the consolidation material was applied to one half, and the other half was kept

1 General Administration of Quality Supervision, Inspection and Quarantine of P.R.C., Standardization Administration of P.R.C. (2008). Method for visual evaluation of metamerism (GB/T 15610-2008).

untreated (Fig. 5). After one month, the colour contrast scale between the treated and untreated parts was evaluated according to the grey scale. The colour change is acceptable when grey scale rating is larger than 4 (Zhang, 2016).



Fig. 5 Earthen samples are divided with a scored line and the consolidant is applied to one half. After curing of the consolidant, the colour difference between the two parts is evaluated to decide the gray scale rating

Three samples were treated with each consolidant material, and the colour average value was selected as an indicator. No colour difference was observed before and after consolidation for MH and TEOS, the colour was darker for the Remmers 300 (Table 2).

Table 2 Colour difference grade of earth samples before and after consolidation

	MH	Remmers 300	TEOS
Sample 1	5	4	5
Sample 2	5	4	5
Sample 3	5	4	5
Average value	5	4	5

3 Gloss Changes

Earth has no gloss, but it is possible that a film with a glossy behaviour may develop after treatment. Gloss was measured according to standards², and calculated as percent change in gloss as follows:

$$\text{Gloss increase \%} = (G_0 - G_1) / G_1 \times 100$$

where, G_0 - final gloss (after treatment), and G_1 - initial gloss (before treatment).

Gloss-increasing-grade is reported in Table 3. The result is the average of three measurements, and no gloss increase has been detected for all the three kinds of consolidating materials (Table 4).

Table 3 Specular gloss grade of soil sample before and after consolidation³

Grade	Visual increase	Instrumental Gloss increase/%
0	No increase	≤3
1	Very slightly increase	4~15
2	Slightly increase	16~30
3	Obviously increase	31~50
4	Seriously increase	51~80
5	Totally increase	>80

Table 4 Specular gloss grade test results

	MH	Remmers 300	TEOS
Sample 1	0.4	0.4	0.4
Sample 2	0.4	0.4	0.4
Sample 3	0.4	0.4	0.4
Average value	0.4	0.4	0.4
grade	0	0	0

² General Administration of Quality Supervision, Inspection and Quarantine of P.R.C., Standardization Administration of P.R.C. (2008). Test methods of specular gloss for decorative building materials (GB/T 13891-2008).

4 Water Vapour Transmission



Fig. 6 Earthen samples were fixed on the top of cylindrical containers that are partially filled with water, sealed with a polytetrafluoroethylene tape, to evaluate the water vapour transmission

The reduction of vapour permeability, induced by the treatments, can cause deleterious phenomena. Therefore, the difference in water vapour transmission was measured between the treated and untreated earth samples.

The whole test process is as follow: samples of $\text{Ø } 61.8 \text{ mm} \times 20 \text{ mm}$ were fixed on the top of identical cylindrical containers which were partially filled with water (Fig. 8). Then, the containers, properly sealed with polytetrafluoroethylene tape, were placed in a desiccator, kept at R.H. 20% and at constant temperature of 30 ± 0.5 (Xu et al., 2012). The containers were weighted every 24h. The water vapour permeability was evaluated by the mass of water vapour passing through the earth sample surface. Three consecutive measurements were taken at a 24-hour interval and mean values were reported. The results are averages of three samples.

$$WVT = \frac{\Delta m}{S \times t}$$

where WVT -water vapour transmission rate, $\text{g}/(30\text{cm}^2 \cdot 24\text{h})$; Δm -weight change, g; S -test area, 30cm^2 ; t -time during which Δm occurred, 24h.

$$\Delta WVT(\%) = \frac{WVT_0 - WVT_1}{WVT_0} \times 100$$

where ΔWWT - WWT change before and after treatment; WWT_0 - WWT before treatment, $g/(30\text{cm}^2 \cdot 24\text{h})$; WWT_1 - WWT after treatment, $g/(30\text{cm}^2 \cdot 24\text{h})$.

The results are shown in Table 5. From this table, WWT of the treatment with TEOS decreases little, the treatments with MH and Remmers 300 give more or less the same values. Taking into account that the groundwater is at a depth of 40 m and the shelter keeps rain off, the 15% of reduction is accepted.

Table 5 Test results of water vapour transmission [$g/(30\text{cm}^2 \cdot 24\text{h})$]

	Untreated	MH	Remmers 300	TEOS
Sample 1	0.77	0.64	0.65	0.72
Sample 2	0.72	0.62	0.62	0.71
Average value	0.74	0.63	0.64	0.72
$\Delta p/\%$	—	14.86	13.51	2.70

5 Shear Strength

The increase in mechanical strength due to consolidation is determined by the direct shear test according to the standards³.

The variation of the shear strength between the treated and untreated samples shows an increase of the cohesion (c/kPa) but a decrease of the angle (φ) of internal friction (Table 6). The increase of cohesion observed for Remmers 300 and TEOS treatments is more or less the same, but for MH it is strongly lower. As for the internal friction, the change is variable among the various treatments. The specific reason needed to be investigated. Ideally, a lower increase in strength is desirable, because it guarantees a mechanical compatibility with the substrate. Shear strength has a positive correlation with compressive strength and therefore with Young's modulus. If there is too much difference in Young's modulus between the treated and untreated earthen samples, the stress related to variation of moisture or temperature might be high enough to damage the interface cohesion between the treated and untreated earth.

³ State Bureau of Quality and Technical Supervision, The Ministry of Construction of the People's Republic of China(1999). Standard for soil test method (GB/T 50123-1999).

Table 6 Test results of shear strength

	Untreated		MH		Remmers		TEOS	
	c/kPa	$\varphi/^\circ$	c/kPa	$\varphi/^\circ$	c/kPa	$\varphi/^\circ$	c/kPa	$\varphi/^\circ$
Sample 1	94.0	28.75	109.9	30.26	273.5	29.65	216.5	24.86
Sample 2	96.3	32.0	157.2	27.3	194.8	30.7	191.8	28.6
Average value	95.15	30.375	133.55	28.78	234.15	30.175	204.15	26.73
Δ	—	—	38.4	-1.595	139	-0.2	109	-3.645
Δ /untreated/%	—	—	40.36	-5.25	146.09	-0.66	114.56	-12.00

6 Thermo-hygrometric aging cycles

The daily and annual thermo-hygrometric cycles to which earth structures are normally subjected are the most probable cause of decay. It is therefore necessary to evaluate the behavior of the treated earth with respect to thermo-hygrometric cycles.

The diffusion of water molecules into the earth and the permeation of water vapour will weaken the bonding force between the consolidant and the earth, and will also weaken the chemical bonding effect of the consolidant itself.

On the one hand, the thermal action will accelerate the diffusion of water molecules, on the other hand it will strengthen the further crosslinking of consolidant to a certain extent. The thermo-hygrometric aging of treated earthen samples is the result of these two aspects.

With reference to the standards^{4,5,6}, the procedure was as follows:

- put the treated samples on the plate with grid, and then place them all into a closed environment at R.H. $96\pm 2\%$ and temperature of $65\pm 1^\circ\text{C}$ for 8h;
- move the earth samples into a closed environment at R.H. $20\pm 2\%$ and at temperature of $20\pm 2^\circ\text{C}$ for 16h
- repeat this cycle 30 times.

$$W_{gi} = (m_1 - m_i) / m_1 \times 100 \quad (3)$$

where, W_{gi} -mass loss of the sample after thermo-hygrometric cycles compared to the mass before aging, %; m_1 -mass before aging, g; m_i -mass after the i^{th} cycle, g.

- 4 General Administration of Quality Supervision, Inspection and Quarantine of P.R.C., Standardization Administration of P.R.C. (2007). Determination of resistance to heat and humidity of paint films (GB/T 1740-2007).
- 5 The Ministry of Construction of the People's Republic of China(1998). Soil stabilizer (CJ/T 3073-1998).
- 6 The State Economy & Trade Commission of the People's Republic of China(1999). Acid-proof and antiseptic coating used for concrete of chimney (DL/T 693-1999).

MH treatment shows a better resistance towards the thermo-hygrometric aging, Remmers 300 places at the second place, and TEOS shows the worst behaviour (Table 7).

Table 7 Thermo-hygrometric aging test results

		Untreated	Treated		
			MH	Remmers 300	TEOS
Earth sample 1	Before aging test/g	100.2130	93.6305	107.9285	96.4216
	10 cycles/g	98.7569	93.4109	106.3282	94.1238
	20 cycles/g	96.4452	93.3374	106.2244	93.1944
	30 cycles/g	25.2513	93.1823	105.7985	91.5622
	$W_{930}/\%$	74.80	0.48	1.97	5.04
Earth sample 2	Before aging test/g	90.0629	91.4164	101.5924	94.0068
	10 cycles/g	88.4970	90.9095	99.4729	93.1550
	20 cycles/g	84.7231	90.7499	99.4663	92.2782
	30 cycles/g	81.3693	90.3177	98.8795	91.1289
	$W_{930}/\%$	9.65	1.20	2.67	3.06
Earth sample 3	Before aging test/g	93.9802	99.2898	104.2880	96.8272
	10 cycles/g	15.8358	98.7494	102.7106	96.5443
	20 cycles/g	0	98.6828	102.65001	95.9407
	30 cycles/g	0	98.3302	102.6024	95.0195
	$W_{930}/\%$	100	0.97	1.62	1.87
Average value	---	61.48	0.88	2.09	3.32
			$W_{930}/\%$		

Summarizing the laboratory tests, we can conclude that the MH treatment shows a better overall behaviour with respect to the Remmers 300 and TEOS for Ruguan Yao kiln site.

FIELD TESTING

For in situ testing, MH was sprayed into the kiln soil continuously and slowly. At first, MH penetrated the soil rapidly, then more and more slowly and liquid MH remained on the surface. When MH remained on the surface for 90s, spraying stopped (Fig. 7).

After 2 hours, a self-made sampling pipe was inserted into the treated soil area to evaluate the penetration depth then the penetration depth with the liquid traces has

been measured as the initial depth (Fig. 8). The final depth was measured according to its hydrophobicity after one month.

The consolidation depth of three test areas is more than 8 cm. There is no colour and gloss difference before and after treatment.



Fig. 7 *In situ* treatment of the consolidant MH by spraying



Fig. 8 Measurement of the depth reached by the consolidating treatment in the field immediately after application: trace of consolidating liquid in the sampling pipe

The *in situ* water vapour transmission test was conducted as follows: firstly, a blue gel indicator of about 40g was put into a plastic cup, and then the cup was covered with a plastic square mesh net. Finally, the cup was fixed on the untreated and treated earth areas with the plasticine.



Fig. 9 *In situ* water vapour transmission test

The mass of water vapour transmission *in situ* can be calculated as follows:

$$WVTF = m_2 - m_1 \quad (5)$$

where *WVTF*- water vapour transmission *in situ*, g; m_1 -weight of cup and blue gel indicator before the start of water vapour transmission, g; m_2 -weight of cup and blue gel indicator after the end of water vapour transmission, g.

The rate of water vapour transmission can be calculated as follows:

$$RWVTF = (m_2 - m_1) / (m_1 - m_0) \times 100\% \quad (6)$$

where, *RWVTF*-rate of water vapour transmission *in situ*, g. m_1 -weight of cup, g.

After MH treatment, the water vapour transmission decreases slightly but this decrease can be considered acceptable (Table 9).

Table 9 Test results of water vapour transmission in field

No.	Cup mass/g	Mass of cup and gel /g	Duration time (h:min)	Mass after absorption/g	Mass of hygroscopicity/g	Rate of hygroscopicity/%
untreated	2.1	42.6	22:49	45.8	3.2	7.90
treated A	2.1	48.7	22:46	52.2	3.5	7.51
treated B	2.3	43.2	22:45	46.1	2.9	7.09
treated C	2.1	42.5	22:44	45.5	3	7.422

The *in situ* test was carried out on 2 July 2010. The treated area has remained in good condition until now.

BIBLIOGRAPHICAL REFERENCES

- XU F., LI D., ZHANG Q., ZHANG H., XU J. (2012), "Effects of addition of colloidal silica particles on TEOS-based stone protection using n-octylamine as a catalyst" in *Progress in Organic coatings*, 75, pp. 429-434.
- YANG Q.Y. (2012), *Study on the Influence of Environmental Factors on Danfeng Gate Site of Daming Palace*, Master's thesis, Northwest university, Xi'an, China, pp. 32-37.
- ZHANG J.F. (2013), *Consolidation Method of Chemical Materials on Earthen Sites*, China Cultural Heritage Scientific Research, 1, pp. 53-57.
- ZHANG J.F. (2016), *Discussion on colour difference by chemical consolidation on earthen sites*, China Cultural Heritage Scientific Research, 4, pp. 51-57.

CONSERVATION MEASURES OF ANCIENT CITY RUIN OF GAOCHANG

JICAI LU

Center of Conservation of Xinjiang Cultural Heritage - CCXCH, Wulumuqi, China

Keywords: Ancient city of Gaochang, weathering, grouting, bolt anchoring, adobe masonry, capping

INTRODUCTION

The province of Xinjiang in China is located in the middle part of “silk road”, with a long history of convergence of four civilizations and the honour of being a “natural museum”. There are 9542 cultural heritage sites today and 113 of which are state-level sites. There are 49 earthen sites out of 113 state-level sites. These earthen sites include ancient city ruins, temples, grottos, tombs, beacon towers, post houses, etc. As for the earthen cities, the ancient city of Gaochang, sited near the oasis of Turfan, still has all the city walls left while the ancient city of Loulan, sited in the middle of the desert, has basically nothing visible on the ground. Some sites, which have existed for more than a thousand years, are in poor conditions because most of them consist of earth, which easily decay, suffering from earthquake, rain and wind, etc. (Zhao H., 2003).

The ancient city of Gaochang is located 35 km east of Wulumuqi city, which today is the capital of the Xinjiang province. It was built in 48 BC and was abandoned in 1275 because of the war. The city has an irregular square shape with an area of 2.2 million m² (Fig. 1). The original city, similar to Chang’an city in Tang Dynasty, consisted of the palace, the inner city and the outer city, which means Tang dynasty’s architectural culture had a deep influence on the construction of Gaochang city. However, what is now visible are mostly the outer walls and several towers.

Different craftsmanships were involved in the process of construction of the city, which has the following construction types:

1. Rammed construction. Most parts of city were built with rammed earth technology, such as the outer city walls, palace walls, Dongta Buddhism tower, etc. Most of the outer walls are well preserved with a width of 12m and a

depth of 11.5m. Some tree branches are still visible among the rammed earth blocks and this kind of technique is still widely used at present in Tulufan region of Xinjiang.

2. Adobe masonry. Some parts, such as Xita tower, Dongnan Buddhism tower, etc. were built in earthen bricks with dimensions 500mm×240mm×110mm or 420mm×220mm×120mm. As masonry mortar, a mixture of mud and straw was used.
3. Excavation. The Kehanbao fort was dug in the ground and this kind of construction ensured excellent thermal insulation in hot summers and cold winters.
4. Stacked mud. There are some building parts built by stacked mud in the northern zone of the city.

The conservation of the ancient ruins of Gaochang has been carried out since 2005, using various measures to counteract collapses, weathering, erosion, etc. Some interventions were effective others less. This article focuses on the detailed measures used in the conservation of Gaochang, with the aim to be a reference for subsequent restorations, because there are basically new collapses every year.



Fig. 1 General aerial view of ruins of Gaochang city (Xinjiang, China)

MAIN TYPES OF DECAY PHENOMENA

Gaochang was abandoned about a thousand years ago. However, in recent years, some farmers have begun to grow crops near the ruins. Like most earthen sites, the ruins of Gaochang suffer various phenomena of decay.

1. Collapse along the city walls (Fig. 2). The walls have been there for almost a thousand of years and there are many factors responsible for their collapses such as rain, wind, earthquake, etc. The earth has an affinity for water and after the rain, the clayey component expands and then shrinks, losing its strength and causing cracks. If this process is repeated several times, the wall may collapse, especially if triggered by the effect of earthquakes.
2. Undercutting due to strong winds (Fig. 3). In this area, there are an average of 36.2 days per year with winds above force 8. The longest duration of winds is 8 days with 8.35h every day. The windward wall surfaces suffer a lot and the masonries acquire a mushroom shape because the wind carries a greater amount of coarse sand at ground level. At the end, with the progressive basal erosion, the masonry collapses.
3. Fissures (Fig. 4). They are formed because of unloading or structural stresses. Unloading cracks are caused by the redistribution of stresses due to the loss of some mass. Structural fractures develop when walls were built utilizing timber planks as a support, and then fracture between planks expands with time.
4. Flaking (Fig. 5). The surface layer of the wall forms a thin coat of dense earth after the rain, which explodes and falls in the case of sunshine, wind, etc. The maximum precipitation per year is 48.4mm in Gaochang region and the minimum is only 2.9mm. In case of rain, that usually happens in summer, the runoff can produce large mudflows. Because of the high summer temperatures (even more than 45 °C), the wet earthen masonry surfaces dry quickly with consequent shrinkage and final falls.
5. Holes due to biological activity (Fig. 6). There are many holes along the bottom of the walls made by wasps or mice. These holes decrease the strength of the earth body and favour the action of water.
6. Human action. Some farmers have built irrigation pipes along the base of the outer city walls, which has a bad influence on the stability of walls. There are some gaps cut by farmers to pass through the walls.



Fig. 2 Collapse of the rammed earth walls



Fig. 3 Rammed earth wall eroded by winds



Fig. 4 Fissures on rammed earth walls



Fig. 5 Thin layer formed on the surface of an earthen wall after rain, subsequently cracked and about to fall



CONSERVATION MEASURES

Different conservation interventions were carried out since 2005, aiming to increase the resistance against decay.

1) Measures against collapse - adobe masonry or bolt anchoring

Those portions of the walls at risk of collapse have been stabilized with adobe masonries supports or bolt anchoring.

Adobe masonry was used when the erosion depth was less than 2m, and an extra buttress was applied if the erosion depth was more than 2m. The bricks were made with the collapsed earth and straw but in case there is no enough collapsed soil, nearby earth was selected according to the colour of the original walls. The dimension of the earthen bricks was the same as the original ones. Before making the adobe masonry support, the loose earthen material was scraped off the walls and a flat hardened foundation was made by pressing the ground. During the construction of the adobe masonries, care was taken not to exceed the height of 0.8m every day to avoid massive structure and therefore a deeper compaction. When we put some adobe masonry together, the overall height will reduce afterwards. If the height is too high, there will be a large reduction in height and this could lead to cracking.

Then drainage holes with a diameter of 20mm were drilled at the height of 0.2m from the bottom to decrease the side effect of uprising underwater. Finally, the shrinkage fissures were sealed with a suitable lean earthen mixture. The criterion of

“Minimum intervention” was followed throughout the process. Fig. 7 and Fig. 8 show the walls before and after the construction of the adobe masonry support.

As for bolt anchoring, basically the same procedure as for ordinary engineering was followed, with the difference that bolts were made of geo-filament wrapped in hemp wire with an epoxy binder instead of steel bar, and the grouting was an earth mixed with cement and fly ash (proportions 85:5:10 in mass) with an addition of 5% silicone acrylic emulsion. The tail of the bolts was driven into the walls for about 100 mm and the top of each bolt was covered with mud.



Fig. 7 General view of rammed earth walls before the construction of an adobe masonry support



Fig. 8 General view of rammed earth walls after the construction of an adobe masonry support

2) Measures against fissure - grouting

The rain can run along the fissures of the walls favouring their collapse, therefore it was important to seal these fissures. First of all, the powdered earthen material inside the fissures was removed. Afterwards, the inner surface of the fissures was moistened and grouting pipes were placed along the length of the fissure every 500mm. The fissures with a width of less than 30mm were filled with a mixture of clay and fly ash and the fissure more than 30mm wide were filled with earth blocks and a grouting slurry. Then, once the surface dried, 5% of silicone acrylic emulsion was put into the pipes to increase the cohesion. The proportion of earth, cement and fly ash was adjusted according to the specific location.

3) Measures against weathering (wind and rain)

(1) Protective coat

The main factor affecting the top of the walls is rain, because rain can wash away the earth. The importance of capping is well-known. Therefore, the main method is to add a protective coat (Fig. 9). This coat protects the top from the direct action of rain, wind, external forces, etc. by acting as a "sacrifice layer" that will be destroyed in place of the original walls. The original walls will be affected by decay decades or even more years later.

The whole procedure was as follows:

- Firstly, the dust on the top of the walls was cleaned up with brushes, etc.
- Then a 20mm thick layer of mud mixed with straw was spread above the walls
- After that, a solid geo-engineering grid was placed on the top of mud/straw layer.
- Finally, a 50mm thick layer made of mud mixed with water repellent material or reinforcement agents was laid to improve resistance to rain and wind.



Fig. 9 Capping of the wall against rain erosion

(2) Consolidation of the earthen walls

The procedure for applying the consolidating product was as follows: scaffolding was placed along the walls and a shading net over it to maintain right temperature and humidity. Then a 5% or 8% silicone acrylic emulsion was used as a consolidating agent for the earthen surface. It was applied with an atomizer spray in three times at an interval of 3-6 hours (Fig. 10). In the case of areas highly exposed to weathering, the application according to the dripping method was utilized (Fig. 11).



Fig. 10 Application of the consolidating product by spraying



Fig. 11 Application of the consolidating product through dripping method

CONCLUSIONS

The conservation of the ruins of the ancient city of Gaochang began ten years ago and was an opportunity to gain considerable experience considering both the successes and the failures of the conservative measures tested.

Examining the current conditions of conservation, the intervention overall showed a good result. Nevertheless, a continuous maintenance is necessary, and also carefully selecting the most suitable conservation methods.

BIBLIOGRAPHICAL REFERENCES

- ZHAO Haiying, LI Zuixiong, HAN Wenfeng, et al. (2003). "The main diseases and causes of soil relics in the arid area of Northwest China" in *Chinese Journal of Rock Mechanics and Engineering*, 22 (2), pp. 2875-2880.
- CUI Kai, CHEN Wenwu, HAN Lin, et al. ,(2011). "Soil salinity deterioration and wind erosion loss effect in the cut-out area of earthen ruins in arid area" in *Chinese Journal of Geotechnical Engineering*, 33 (9), pp. 1412-1418.
- ZHAO Xiaowen (2014). "The influence on cracks and reaction mechanism of plants on the conservation of earthen sites", Northwest A&F University, Yangling, Shaanxi, China.
- LI Yipeng (2007). "The anchor arm reinforcement and resistance to weathering research of ancient ruins of Gaochang", Xi'an university of architectures and technology, Xi'an, China, pp. 13-14.

ARCHAEOLOGICAL SITE OF LAJIA RUINS: PRELIMINARY STUDY ON THE SCREENING OF REINFORCING MATERIALS FOR EARTHEN RUINS

MIN FAN^{1,2}, YINGYI FU², YUE CHEN¹, GUANGZHAO ZHANG³

¹ Baiyun Cultural Heritage Conservation Engineering Co., Ltd., Guangzhou, China

² Hanrui Research and Design Center of Cultural Heritage Conservation,
Guangzhou, China

³ South China University of Technology, Guangzhou, China

Keywords: Lajia ruins, earthen masonries decay, peeling, reinforcement

ABSTRACT

The effectiveness of the reinforcement treatments of earthen archaeological masonries largely depends on the compositional/physical properties of the earthen mass and on the environmental conditions where the archaeological site is located. In this paper, in view of the conservation of earthen Lajia Ruins in Qinghai Province (China), the compositional characterization of the earth and tests to realize more durable earthen mixes were carried out in order to select the most suitable reinforcing products. The evaluation tests include colorimetric tests, unconfined compressive strength, penetration depth and freeze-thaw cycles. The experimental results show that the earthen mixes with the addition of BYG1003 showed the best performances against decay.

INTRODUCTION

Located in Lajia Village, Guanting Town, Minhe Hui Nationality Autonomous County, at 101°05'-103°01' east longitude and 35°42'-37°09' north latitude, Lajia Ruins represent a large-scale Bronze age settlement sited along the upper Yellow River. Its cultural connotations incorporate Majiayao culture, Qijia culture and Xindian culture. The effects of the multiple disastrous events such as prehistoric earthquakes

and the Yellow River floods or mudslides have been observed at the site, making it an extremely rare prehistoric site (Wang, 2008). Due to its significant value, the Lajia ruins were named one of the “National Top Ten Archaeological Discoveries” in 2001 (Qu, 2002), and the site was approved by the State Council to be included the fifth batch of “National Key Cultural Relics Protection Units”. In 2005, during the 11th Five-Year Plan period, it was identified as one of the 100 major historic sites by the State Administration of Cultural Heritage. In 2013, it was included in the list of the second batch of national archaeological site park.

CHARACTERISTICS AND DECAY PHENOMENA OF THE LOCAL SOIL

1 Compositional characteristics of the local soil

The intrinsic factors linked to the deterioration of earthen sites depend on the compositional characteristics and physical properties of the earthen material. Therefore, in the long-term conservation of earthen sites, the full understanding of the physical-chemical characteristics of the earthen material is necessary.

Lajia Ruins are located in the Guanting Basin, a small intermountain basin in the upper reaches of the Yellow River. Starting from the Jishi Gorge in the west and reaching the Sigou Gorge in the east, Guanting Basin is about 12 kilometres long from east to west and about 5 kilometres wide from north to south, and has an area of about 60 square kilometres. Furthermore, the basin is surrounded by mountains with an altitude of about 2,100 meters, mainly composed of purplish red and red Cretaceous sandstone. Plateaus composed of loess and red soil are widely present in front of the mountains (Zhang et al., 2009). These materials were utilized to make the masonries of the archaeological site. Since the soil properties of different earthen sites vary widely as well as and the forms of decay, in this study, soil samples collected from the Lajia site numbered F29 were tested and analysed to identify the composition, structures and properties.

The soil samples were burned in a muffle furnace at 900° to test the LOI (loss on ignition). The chemical composition was detected by X-ray fluorescence spectrometer and the grain size distribution was carried out by sieving according to the following fractions: sand 2-0.075 mm, silt 0.075-0.005 mm, clay < 0.005 mm). The mean granulometry is the following: sand 1.8 %, silt 83.23%, clay 14.97%. Therefore, according to the standard¹, the bulk soil of Lajia Ruins is regarded as a silty soil.

1 Engineering Classification Standard for Soil [S]. Beijing: Standards Press of China, 2007(GB/T 50145-2007).

2 Physical and mechanical characteristics of samples taken from the local soil

The physical characteristics of the soil samples taken around the site are shown in Table 1.

The soil samples shown a low strength, being subject to shrinkage, cracking, collapsing or water swelling with changing seasons.

Table 1 - Physical characteristics of the soil samples

Test	Measured value on soil samples
Water content (%)	7.33
Wet density (g/cm ³)	1.502
Dry density (g/cm ³)	1.390
Specific gravity	2.71
Plastic limit (%)	15.66
Liquid limit (%)	26.51
Cohesion (kPa)	180.3
Internal friction angle (°)	12.41
Free swell (%)	16
Unconfined compressive strength (MPa)	1.16
Tensile strength (MPa)	0.75
Electric conductivity (μs/cm)	205
pH	7.6

3 - Main decay phenomena

There are many typical decay phenomena in Lajia Ruins (area F29), such as wind erosion grooves, fissures and....., fissure and destruction caused by tree growth, etc.. The wind erosion stripping and the damage due to plants are the most serious. The decay due to the action of the wind leads to the detachment of the earth in the weakest parts of the wall ruins which is eroded by the wind in flakes or small pieces and falls, forming an irregular honeycomb shape on the wall or leaving some small protrusions, such as shown in Fig. 1 and Fig. 2. Changes in water content of soil, air temperature and humidity will promote the development of weathering layers with different physical-mechanical and chemical properties in respect to the substrate. The damage due to plant growth can be divided into the presence of moss, turf, shrubs and trees. The damage due to biodeteriogens in the Lajia Ruins was also caused by microorganisms, as shown in Fig. 3 and Fig. 4. As the site area is outdoors, changes in temperature, humidity, light, nutrient source, etc. in some areas of the site they lead to growth and reproduction of algae and moulds.



Fig. 1 Weathering of a southern surface of area F29 of the Lajia site



Fig. 2 Weathering of western surfaces of area F29 of the Lajia site



Fig. 3 Surface blackening in area F29 due to algae development



Fig. 4 Biodegradation caused by mould in area F29 (red square)

EARTHEN SAMPLES REINFORCEMENT TESTS

1 Selection of the consolidating products

The earthen samples obtained from the local soil have been consolidated with the following products:

1. Silicate grout: the main component is an admixture of potassium silicate and sodium silicate. The concentration of the material to be tested is 7% and the viscosity is low. After the silicate grout has penetrated into the soil, the soil has significantly improved its mechanical strength and has good resistance to atmospheric erosion and freeze-thaw cycles (He, 2007).

2. Ethyl orthosilicate grout: the main component is ethyl orthosilicate; the content of SiO_2 is about 38-42%, the solution concentration is 5%; after the reaction with the soil, SiO_2 is produced.
3. BYG1003 reinforcing agent: it is the series of soil reinforcement products of Baiyun Cultural Heritage Conservation Engineering Co., Ltd. (Guangzhou, China). The main component is ethyl silicate and its oligomers, and the solution concentration is 80%. The material is colourless, transparent and highly permeable. Combined with the aggregate minerals from the rock mass, the material generates Si-O-Si chemical bonds, strengthening the surface of the soil site.
4. Silicone-acrylic emulsion grout: the main component is silicone acrylic emulsion, and the solution concentration is 5%. The mass of silicone monomer is 8%, indicating a best comprehensive performance of the emulsion. The emulsion has the combined advantages of silicone and acrylic emulsions and its cured product is similar to the soil in terms of main components. It is also characterized by excellent weather resistance, temperature resistance, high mechanical strength and long service life of 15 to 20 years (Wang, 2011).

2 Experimental methods and operating procedures

2.1 Preparation of reshaped samples

1. A plurality of reshaped samples were prepared using a mould; among these samples those with a height of 120 mm and a diameter of 20 mm were used for measuring the penetration depth, the samples with a height of 62 mm and a diameter of 20 mm used in the wetness test, and the samples with a height of 20 mm and a diameter of 20 mm were used in other tests.
2. The milled air-dried soil was passed through a 20-mesh sieve and then a suitable amount of passing material was taken to measure the water content in the air-dried soil.
3. Water was added to the air-dried soil samples in order to reach the optimal moisture content (18%-19% for Lajia site soil), and the admixture was thoroughly mixed and then placed in a closed container for 24 hours.
4. With reference to the standards², the test samples were prepared by compacting on one-time pressure moulding, in order to ensure uniformity of the sample density and compliance with dimensional requirements (Fig. 5 and Fig. 6).
5. The prepared reshaped samples were placed in a cool and dry place for air-drying drying and subsequent use (generally after no less than 3 days).

2 Standard for geotechnical test methods [S]. Beijing: Standard Press of China, 1999(GB/T 50123-1999).



Fig. 5 Remoulded sample blocks at different heights



Fig. 6 Remoulded samples all 62 mm high

2.2 Reinforcing method

The soil samples were divided into five groups, one of which was used as a reference group without reinforcing, and the remaining four groups were reinforced with the four different reinforcing materials respectively. The volume of the cylindrical samples was measured and the chemical material content for the treatment was calculated according to the requirements of the technical specifications of soil protection tests. Finally, the upper and lower bottoms and the side of the samples were uniformly sprayed (or brushed) with the reinforcing materials.

3 .Testing and characterization

3.1 Penetration depth

Three samples (20 mm in diameter and 120 mm in height) were placed on a porous stone, then in a container; the reinforcing materials were added until the solution reached the top surface of the porous stone (i.e. the bottom surface of the soil sample). The penetration height of the reinforcing material was measured after 12 h. The steps were repeated until all reinforcing materials were added.

Fig. 7 shows the experimental process of the depth of infiltration in the soil sample of the four treatments with reinforcing materials

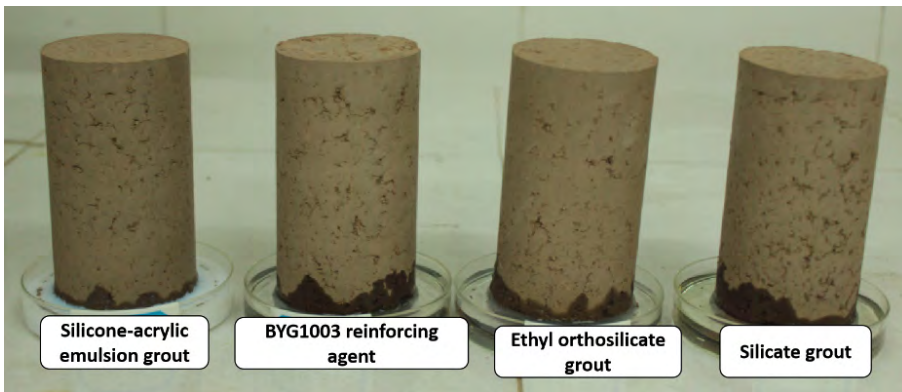

Fig. 7 Penetration depth test on cylindrical soil samples treated with four reinforcing materials

3.2 Unconfined compressive strength

The unconfined compressive strength of test samples was tested according to standards², in each group of three samples and the average value of compressive strength of the three samples was taken. Then the increasing rate of unconfined compressive strength of the samples after the reinforcement treatment was calculated and finally the mechanical properties before and after the reinforcement treatment were compared.

3.3 Colour difference

DC-P3 automatic colorimeter was used to measure the chromatic values of the surface of the three samples before and after the reinforcement treatment. It is required that each measuring point before and after the reinforcement should be correctly compared during the measurement process. The samples were then placed flat for curing (to prevent interference). Finally the average value of the colour difference ΔE^* was calculated.

3.4 Dry-wet cycle test

The dry-wet cycle test was carried out according to the test method specified in chapter 6 of the standard³. After 80 cycles, the changes in surface structure of the samples were observed and recorded.

3 Technical specification for soil relics protection test [S]. Beijing: Cultural Relics Publishing House, 2012 (WW/T0039-2012,).

3.5 Freeze-thaw cycle test

The freeze-thaw cycle test was performed in accordance with the testing method specified in Chapter 7 of the standard⁴. After 10 cycles, the changes in surface structure of the samples were observed and recorded.

3.6 Wind erosion test

The wind erosion test was carried out according to the testing method specified in Chapter 8 of the standard⁴, to obtain the wind erosion resistance of the samples after the reinforcement.

3.7 Shrinkage test

The volume shrinkage test was carried out in accordance with the testing method specified in Chapter 9 of the standard⁴, to obtain the volume shrinkage rate after the reinforcement.

4 Discussion of test results

4.1 Penetration depth

The depth of penetration is an essential indicator for the reinforcement of the earthen artefacts. If the penetration depth is too low, only the surface is reinforced rather than the internal structure of the soil sample, easily leading to the formation of crusts. Through the comparison by different time gradients, the depth of penetration of the four reinforcing agents on the soil samples at different times was obtained. Each group of samples was placed on the porous stone and then placed in the container; the reinforcing materials were added till the liquid surface went up to the top surface of the porous stone (i.e., the bottom surface of the soil sample). The penetration time and depth of the reinforcing material was measured within 12 hours, and the average value of three samples was calculated. Table 2 shows the penetration depth of the soil samples reinforced with four reinforcing materials by capillary action for 12 h and it varies greatly. Silicone-acrylic emulsion material has the poorest penetration depth, only 4.26 cm, and the penetration results by capillary action of the other three materials are not much different.

⁴ Technical specification for soil relics protection test [S]. Beijing: Cultural Relics Publishing House, 2012 (WW/T0039-2012).

Table 2 - Penetration depth of soil samples reinforced with different products

Time [h]	Penetration depth [cm]			
	Silicate	Ethyl orthosilicate	BYG1003	Silicone-acrylic emulsion
0	0	0	0	0
0.5	2.48	2.43	2.23	1.02
1	3.62	3.67	3.54	1.81
2	4.72	4.71	5.12	2.35
4	6.04	5.93	6.28	2.57
6	7.23	7.04	7.36	3.26
12	10.89	10.78	11.0	4.26

4.2 Increase rate of unconfined compressive strength

Table 3 shows that after the reinforcement respectively with four reinforcing materials, the compressive strength of the soil samples has been improved; among them the soil sample reinforced with BYG1003 has the highest increase in its compressive strength, followed by soil samples reinforced with silicate and silicone-acrylic emulsion, and the soil sample reinforced with ethyl orthosilicate has the lowest strength improvement. As measured by the unconfined compressive strength, the soil sample reinforced with BYG1003 has an obvious increase in strength.

Table 3 - Compressive strength of soil samples before and after reinforcement by different reinforcing materials

	Compressive strength [MPa]	Increase rate of strength [%]
Blank sample	5.05	--
Silicate	6.76	33.86
Ethyl orthosilicate	6.28	24.36
BYG1003	6.98	38.22
Silicone-acrylic emulsion	6.48	28.32

4.3 Colour difference before and after reinforcement

The reinforcement treatment has been performed following the principle of preserving the original appearance of the cultural relics as much as possible, that is, the colour should not change significantly. Table 4 shows that the maximum ΔE^* value of the ethyl orthosilicate reinforced soil, the silicate reinforced soil, the BYG1003

reinforced soil and the silicone-acrylic emulsion reinforced soil are 3.63, 2.03, 1.86 and 3.19, respectively. It is indicated that after the reinforcement, the ethyl ortho-silicate reinforced soil has a relatively large colour change, while the BYG1003 reinforced soil has a lowest colour change.

Table 4 - Colour difference of soil samples after reinforcement by different reinforcing materials

	Blank sample	Silicate	Ethyl orthosilicate	BYG1003	Silicone-acrylic emulsion
ΔE^*	---	2.03	3.63	1.86	3.19

4.4 Dry-wet cycle test

Table 5 indicates that silicate and BYG1003 reinforced samples have no significant change after 80 dry-wet cycles, yet ethyl orthosilicate and silicone-acrylic emulsion reinforced samples have relatively poor results in dry-wet cycle test.

Table 5 - Dry-wet cycle test results of samples

Samples	Change of wet-dry cycling resistance
Silicate reinforced sample	No change after 80 cycles
Ethyl orthosilicate reinforced sample	Cracking on surface after 47 cycles
BYG1003 reinforced sample	No change after 80 cycles
Silicone-acrylic emulsion reinforced sample	Cracking on surface after 63 cycles

4.5 Freeze-thaw cycle test

Located in Qinghai Province, Lajia Ruins suffer maximum temperatures of 30-35°C and a minimum temperature up to -24°C (Gao, 2010). Therefore, it is important to evaluate the resistance to the freeze-thaw cycles. Table 6 indicates that the soil samples treated respectively with ethyl orthosilicate and silicone-acrylic emulsion materials were pulverized after 4 cycles, and the soil samples treated respectively with silicate and BYG1003 materials maintain their cohesion up to 10 freeze-thaw cycles. The BYG1003 reinforced sample shows the best performance without showing signs of deterioration after 10 freeze-thaw cycles.

Table 6 - Freeze-thaw cycle test results after 10 cycles

Main component	Initial volume, V0 (cm ³)	Volume after 10 cycles, V (cm ³)	Volume change after 10 cycles (%)	Description of change in form
Silicate	157.87	157.09	0.49	Cracks appear after the first cycle and expand in the second cycle, and develop completely after the third cycle and is maintained until the 10th cycle.
Ethyl orthosilicate	156.39	--	--	The upper and lower parts begin to exfoliate during the second cycle; the remaining middle part begins to exfoliate in the third cycle; in the fourth cycle cracks appear in the middle part
BYG1003	158.56	157.98	0.37	No significant change
Silicone-acrylic emulsion	159.93	--	--	Cracking occurs in the fourth cycle; the crack runs through the sample in the seventh cycle; and the eighth cycle leads to broken sample

4.6 Wind erosion test

The wind erosion tests show that the soil samples reinforced with silicate and BYG1003 have the least mass loss by erosion, and little difference in wind erosion modulus. Therefore, as shown in Table 7, the soils reinforced with silicate and BYG1003 will effectively stand up to sand erosion. The silicone-acrylic emulsion reinforced soil sample shows the largest mass loss by erosion, up to 48.73 g, and the value of the wind erosion modulus is half of the untreated sample.

Table 7 - Wind erosion test results

Sample and treatment	Erosion duration t (min)	Erosion area S (cm ²)	Height from ground h (cm)	Erosion rate V (m•s ⁻¹)	Mass before erosion M ₀ (g)	Mass after erosion m ₁ (g)	Amount of erosion Δm (g)	Wind erosion modulus E (kg•m ⁻² •h ⁻¹)
Blank sample	30	33.76	10	18	286.02	198.64	87.38	51.77
Silicate	30	34.87	10	18	285.87	261.95	23.92	13.72
Ethyl orthosilicate	30	33.82	10	18	286.38	252.25	44.13	26.10
BYG1003	30	33.19	10	18	285.69	263.53	22.16	13.35
Silicone-acrylic emulsion	30	34.08	10	18	286.19	237.46	48.73	28.60

4.7 Shrinkage deformation test

Table 8 reports that when the soil is treated with silicate and BYG1003 reinforcing agent, the volume changes not much, only by 0.22% and 0.90%, respectively. The largest change in volume occurs in the soil sample reinforced with silicone-acrylic emulsion, with a shrinkage rate of up to 2.85%.

Table 8 - Shrinkage deformation test

Sample	Volume shrinkage α (%)
Silicate reinforced sample	0.90
Ethyl orthosilicate reinforced sample	1.46
BYG1003 reinforced sample	0.22
Silicone-acrylic emulsion reinforced sample	2.85

In summary, soil samples reinforced with four reinforcing products (silicate, ethyl orthosilicate, BYG1003 reinforcing agent, silicone-acrylic emulsion) have been compared concerning penetration depth, compressive strength, colour difference, wet-dry cycling resistance, freeze-thaw resistance, wind erosion resistance and shrinkage deformation before and after the reinforcement and the results are as summarized in Table 9.

Table 9 - Reinforcing effect of soil samples treated with four types of reinforcing materials

Performance indicator	Silicate	Ethyl orthosilicate	BYG1003	Silicone-acrylic emulsion
Penetration depth [cm]	10.89	10.78	11.00	4.26
Compressive strength improvement rate [%]	33.86	24.36	38.22	28.32
Change of color difference [ΔE^*]	2.03	3.63	1.86	3.19
Dry-wet cycle [cycle]	80	47	80	63
Freeze-thaw cycle [cycle]	10	4	10	8
Wind erosion modulus [$\text{kg}\cdot\text{m}^2\cdot\text{h}^{-1}$]	13.72	26.10	13.35	28.60
Shrinkage deformation [%]	0.90	1.46	0.22	2.85
Comprehensive Evaluation	Good	Poor	Excellent	Average

The laboratory tests performed on reinforced soil samples reveal that silicate and BYG1003 have good reinforcement and protection effect with small colour change, outstanding water resistance, improved compressive strength and good penetration depth of the consolidating product.

CONCLUSIONS

In this paper, the preliminary tests on the reinforcement of earthen samples obtained from the soil taken from around Lajia Ruins have been carried out. The effectiveness of the reinforcement treatments highlighted the following trend: BYG1003 reinforcing agent > silicate > ethyl orthosilicate > silicone-acrylic emulsion. The Qinghai Province where Lajia Ruins are located, belongs to the plateau climate, characterized by few rains and large temperature fluctuation throughout the year. Therefore, freeze-thaw resistance and dry-wet resistance were very important characteristics to consider. According to the results of freeze-thaw cycles and dry-wet cycles, BYG1003 reinforcing agent showed the best performances, followed by silicate. The ethyl orthosilicate monomer showed relatively poor freeze-thaw resistance and dry-wet resistance.

BIBLIOGRAPHICAL REFERENCES

- Gao Zh. W. (2010). "Reinforcement and protection of the site of Lajia Ruins", China's Tu Nationality, 02, pp. 49-51.
- He F.G., Chen W.W., Zhang J.K. (2007). "Experimental study on PS material reinforced soil of Jiahe Old Town", Dunhuang Research, 05, pp. 32-35.
- Qu Zh. H. (2002). "2001 National Top Ten New Archaeological Discoveries", China Private Economy of Science and Technology, pp. 120-122.
- Wang F, Wang Ch.M. (2008). "Analysis of the architectural conservation mode of Lajia Ruins in Qinghai Province", Architecture and Culture 2008 International Symposium, pp. 12-18.
- Wang Y. (2011). "Research on silicone-acrylic emulsion for reinforcement and protection of soil sites and its new formulation", Sichuan Building Science, 37/04, pp. 227-229.
- Zhang X.H, Xia Zh.K, Yang X.Y. (2009). "Re-discussion on the causes of the abandonment of Lajia Ruins in Qinghai", Archaeology and Cultural Relics, 01.

PRESERVATION OF THE CHANGSHA TONGGUAN KILN SITE: EVALUATION OF THE EARTH PROPERTIES AND THE REINFORCEMENT EFFECT OF TREATMENTS

YA XIAO^{1,2,3}, WEIQIANG ZHOU⁴, FENG GAO⁵, HAIBIN GU^{2,3}, YUN FANG⁶, SHAOJUN LIU^{1,3}

¹ Powder Metallurgy Research Institute, Central South University, Changsha, 410083, China

² Cultural Relics and Archaeology Institute of Hunan, Changsha, 410008, China

³ Hunan Key Laboratory for Scientific Archaeology and Conservation Science, Changsha 410083, China

⁴ School of cultural heritage, Northwest university, Xian 710069, China

⁵ Chinese Cultural Heritage Academy, Beijing 100029, China

⁶ Cultural Heritage and Geotechnical Relics Protection Engineering Center, China University of Geosciences (Wuhan), Wuhan, 430074, China

Keywords: Earthen ruin; silicone; natural hydraulic lime; restoration, reinforcement

INTRODUCTION

Historical earthen sites are an important part of the cultural heritage but can be easily damaged by water, wind and soluble salts (Sun, 2007; Sun, Li, 2007; Li, 2006). Chemical reinforcement materials occupy a prominent position in the study of protection of earthen sites from weathering (Zhou H., 2004; Hu, 2010). At present, the research on the protection and reinforcement materials of earthen sites in China focuses mainly on products capable to guarantee good performances in the dry and cold regions of the west (Wang, 2009; Wang, 2003; Chen, 2007). Several chemical materials including PS (a kind of high modulus K_2SiO_3 solution) (Wang 2008; Zhao, 2006; Su, 2000), fluoropolymer (He, 2002) and acrylic non-aqueous dispersion system (Zhou, 2003; Zhou S.L., 2004) have been applied for the protection and reinforcement of historical earthen sites in these regions. Instead, the research on the protection of

earthen sites in moist environments has been carried out at the Tangshan site of Liangzhu Culture in Zhejiang (Zhou, 2008) and at the Jinsha site in Sichuan (Li, 2009) where abundant and heavy rainfalls strongly hit the earthen buildings. Despite this, the earthen sites are severely eroded. This fact indicates that studying the protection of earthen sites in the humid environment is still a difficult task to accomplish (Liu, 2013).

The Tongguan kiln site in Changsha, Hunan province, has unique and important historical, cultural, artistic and scientific values in ceramics history. It is a kiln site more than 1000 years old from Tang to Five Dynasties periods and it is the birthplace of the underglaze colour ceramics. Centred in Wazhaping site, the Tongguan kiln site has 17 kiln ruins including Tanjiapo and Lanjiapo, of which the Tanjiapo site is the most intact. Figure 1 (a) and (b) shows the archeological ruins and long kiln in the museum of Tanjiapo site, respectively.

The circulation of dry and humid air and surface transpiration, in addition to the serious damage caused by the incineration of the core area, have also caused various pathologies, such as cracking of the kiln body, pulverization of the archaeological interface, powdering of the residual pottery surface. In addition, the geographic environment of the Tongguan kiln in the southern humid region within 1km from the east bank of the Xiangjiang River further exacerbates the occurrence of soil erosion and surface weathering, which further threaten the long-term preservation of the Tongguan kiln site. Based on the analysis of the chemical composition and physical-mechanical properties of the soil samples from the Tongguan kiln site, this paper focuses on the assessment of the reinforcement effect of the site and the screening test of reinforcing materials. The results of this paper can provide basic data and conservation strategies for the protection of a large number of important earthen sites in southern humid areas, including Tongguan Kiln site, Laosicheng Site and Chengtoushan Site.



Fig. 1 (a) Archeological relic; (b) Long kiln in the museum of Tanjiapo site

EXPERIMENTAL APPROACH

The earth samples used in this paper were collected from the following regions: the Tongguan kiln and the Long kiln site inside the museum of Tanjiapo site; the open-air site region; the ground surface of the Tongguan kiln site. The samples were marked as 1# (earth sample from the museum), 2# (earth sample from the open-air region) and 3# (earth sample from ground surface). X-ray fluorescence (XRF), X-ray diffraction (XRD), and scanning electron microscope equipped with energy dispersive X-ray detector (SEM-EDX) were used for characterizing the microstructure and the chemical-mineral composition of the earth samples.

Earth samples for the consolidation and selection of the restoration materials and the evaluation tests were uniformly moulded from an iron frame. Before moulding, the collected samples were ground and sieved. The final size of the samples after moulding was about 5 cm × 5 cm × 7 cm. During the preparation process, an appropriate amount of water was maintained to ensure that the moisture of earth is always moderate. Additionally, all the samples have a similar degree of compactness when controlled by weight. Twelve samples were prepared for each kind of earth, and dried at 105°C for 24 hours before being used.

It is important that the protection materials used for the restoration of the earthen sites are capable to satisfy the necessary conservation requirements, such as colourless, non-glare, low viscosity, good fluidity, small shrinkage, good wettability, strong permeability, moderate bonding ability, as well as structurally similar to the earth (Tian, 2011). Furthermore, in view of the climatic characteristics of the humid regions of southern China, the consolidation materials should have good water resistance as well as good permeability, resistance to light, temperature and humidity change, UV, heat, acid and alkali corrosion, and freeze-thaw cycle (Yuan 2002). The three consolidation materials tested in this paper are KSE OH300 (ethyl silicate) produced by the company BioLine (China), silicone Wacker OH 100, and Primal SF 016 (aqueous acrylic emulsion dispersion) with 50% solid content.

The consolidation products were applied through unilateral permeation and complete immersion. Through the unilateral permeation it is possible to test the permeability and the penetration depth of the different consolidating products.

As for the application through unilateral permeation, the samples were kept in contact with the consolidating product through one side of the samples (3 mm above the bottom of the sample). Then, the ascending level reached through capillary force of the consolidating material was recorded after 1 minute, 3 minutes, and 5 minutes, respectively. Meanwhile, the weight of the samples was determined and the absorption rate was calculated. The chromatic alteration and surface hardness of the consolidated samples were measured after three weeks curing at room temperature as well.

Regarding the application through complete immersion reinforcement, the consolidation absorption rate, chromatic alteration, capillary water absorption rate, surface hardness and water resistance were tested.

The chromatic alteration and surface hardness were tested by a DC-P3 automatic colorimeter (Xingguang, Beijing) and an EPUO-TIP2 Leeb hardness tester (Fuji, Japan). The capillary water absorption rate was tested by Custer bottle. These detailed test procedure was described in the reference (Liu, Sun, Gao et al. 2013).

RESULTS AND DISCUSSION

1 Chemical composition and mechanical properties of the earthen site

Figure 2 shows the SEM-EDX results of the earth samples. The SEM images clearly show the loose structure of the lamellar morphology of earth. EDX results show that the main chemical compositions include O, Si and Al, and a small amount of Fe and K. The XRF results (Table 1) show that the main chemical composition are SiO_2 (68~70 wt.%), Al_2O_3 (18~20 wt.%), Fe_2O_3 (6.3~7.0 wt.%), and a small amount of K_2O , CaO and MgO. It is consistent with the EDX results.

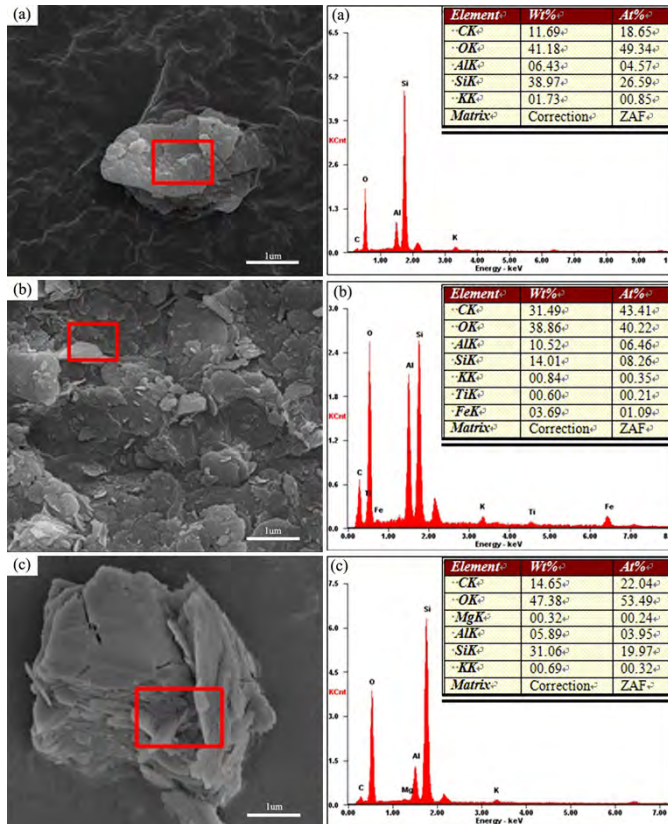

Fig. 2 SEM-EDX results of the three earthen samples; (a) 1# (earth inside the museum); (b) 2# (earth from the open-air); (c) 3# (earth from the ground surface)

Table 1 XRF results of the earth samples in the Tongguanyao site

Sample name	Oxide content (wt.%)									
	SiO ₂	Al ₂ O ₃	Fe ₂ O ₃	K ₂ O	CaO	TiO ₂	MgO	P ₂ O ₅	Na ₂ O	Other
1# (earth inside the museum)	68.285	19.902	6.943	1.722	0.419	1.119	0.687	---	0.180	0.743
2# (earth from the open-air)	69.803	18.486	6.391	1.486	1.235	0.918	0.862	0.386	0.156	0.277
3# (earth from the ground surface)	69.152	18.321	6.237	2.158	1.347	1.035	0.816	0.454	0.193	0.287

Figure 3 shows the XRD results of the earth samples. In addition to the clearly visible diffraction peaks of quartz, the peaks near 19.7°, 34.6°, and 37.6° correspond respectively to those of mica. Furthermore, the diffraction peaks characteristic of kaolin are also present in the three kinds of earth samples. Consistent with the results of EDX and XRF, the XRD results indicate that the main components of the earth of Tongguan Kiln site include quartz, mica and kaolin. We would like to mention that a small amount of pearl clay, which is the weathering product of aluminosilicate, is found in the sample taken in the open-air.

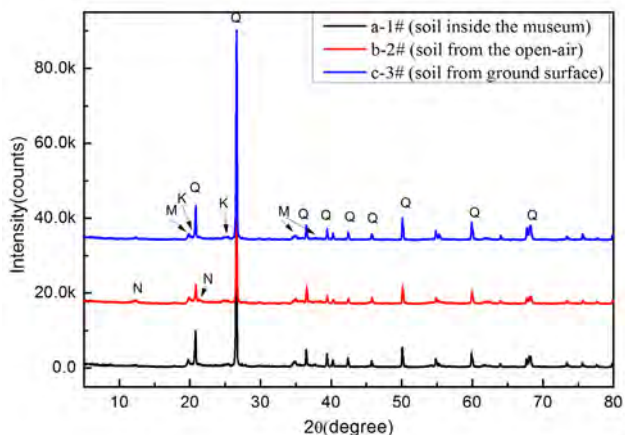

Fig. 3 XRD results of the earthen samples collected in the Tongguanyao site (Q-quartz, M-mica, K-kaolin, N-nacrinite)

The performance of the earthen artefacts sited in humid environments often depends on the relative humidity of the micro-environment and the local climatic conditions (Zhang, Li, Wang et al. 2011). It should be pointed out that the test specifications about the treatments to be carried out in earthen artefacts sited in humid

areas have not yet a standard test specification compared to those located in relatively dry areas. Therefore, this paper focuses on testing the physical properties such as plasticity, compressibility, and permeability of the earth samples collected from the Tongguan Kiln site. Table 2 provides a comprehensive comparison of the physical and mechanical properties of earth samples. As seen in Table 2, the density of the earth samples is almost the same, ranging from 2.71 to 2.73 g/cm³. In contrast, the other major physical and mechanical properties of the earth samples, such as water content, void ratio, porosity, saturation, liquid limit, plastic limit, plasticity index, liquidity index, compression index, compression modulus, and permeability coefficient, are varied within a wide range. Among them, the water content of the yellow-brown samples, the dark brown samples and the dark red samples is significantly different. In contrast, the porosity of the dark brown samples and the dark red samples is much higher than that of the yellow-brown samples.

Table 2 Physical and mechanical properties of the earth samples from the Tongguan kiln site

Sample				yellow-brown samples	dark-brown samples	dark-red samples	
Physical properties	Water content	W	%	18.0	24.5	24.7	
	density	wet	ρ	g/cm ³	1.82	1.62	1.50
		dry	ρ_d	g/cm ³	1.54	1.30	1.20
	Grain density	ρ_s	g/cm ³	2.73	2.72	2.71	
	Void ratio	e	---	0.770	1.090	1.253	
	Porosity	n	%	43.5	52.2	55.6	
Saturation	Sr	%	63.8	61.1	53.4		
Plasticity	Liquid limit	W _L	%	34.6	34.5	32.5	
	Plastic limit	W _P	%	17.7	19.6	20.0	
	Plasticity index	I _P	%	16.9	14.9	12.5	
	Liquidity index	I _L	---	0.02	0.33	0.38	
Compressibility	Compression index	a _{l-2}	MPa ⁻¹	/	0.58	0.79	
	Compression module	E _s	MPa	/	3.60	2.85	
Permeability	Permeability coefficient	K ₂₀	cm/s	9.52x10 ⁻⁶	/	/	

Note: "/" means that the parameter was failed to obtained

2 Evaluation of the earth reinforcement effect

The unilateral permeation is an effective method to test the penetration rate and depth of different consolidation materials. Table 3 summarizes the results of the unilateral permeation reinforcement performance of the earth samples, from the Tongguan kiln site, after 5 min of treatment. Regarding sample 1# (earth inside the museum), the penetration depth of KSE OH300 reached 4cm, while that of Wacker OH 100 and Primal SF 016 was only 3cm. The restoration and consolidation of earthen artefacts requires that the chromatic change before and after the application of the product cannot exceed 5 (Su, Li, Hu 2000). As showed in Table 3, the chromatic alteration of the samples consolidated with KSE OH300 is the smallest after the treatment by unilateral permeation reinforcement and all samples are less than 1.5 so that it is too small to be distinguished by the naked eyes. In addition, the surface hardness of the samples consolidated with KSE OH300 is increased by at least 40% relative to the original sample. Moreover, except for sample 3# (earth from ground surface), the chromatic alteration of the samples reinforced with Wacker OH 100 can meet the basic requirements for their application in the earthen artefacts protection. However, the hardness of the samples consolidated with Wacker OH 100 is better than that obtained with the other two products. In contrast, the chromatic alteration after the application of Primal SF 016 is above 4, and the hardness increase is less than 5%. These results show that KSE OH300 applied through unilateral penetration has relatively good efficacy in the consolidation of the earthen artefacts.

Table 3 Sample properties test results after unilateral penetration reinforcement

Sample name	Consolidation products	Rising height (cm) of the product after 5 min of treatment	Chromatic change ΔE^*	Surface hardness (HLD)		
				before	after	difference
1# (earth inside the museum)	KSE OH300	4	0.44	265	376	111
	Primal SF 016	3	4.34	260	269	9
	Wacker OH 100	3	3.02	230	398	168
2# (earth from the open-air)	KSE OH300	2	1.33	271	383	112
	Primal SF 016	1.5	4.50	261	270	9
	Wacker OH 100	2	1.39	282	400	118
3# (earth from ground surface)	KSE OH300	3	0.90	217	321	104
	Primal SF 01	3	8.13	223	234	11
	Wacker OH 100	2	6.04	227	360	133

After the complete immersion reinforcement, tests were performed to evaluate the absorption rate, chromatic alteration, surface hardness, capillary water absorption coefficient, and water resistance performance of the earth samples. Initial observation reveals no significant change in the samples completely immersed in KSE OH300 and Wacker OH 100. However, an initial disintegration is observed for earth samples immersed in Primal SF 016. This is due to the volume expansion caused by the water absorption during the complete immersion process. In order to achieve a more accurately evaluation of the reinforcement effect of Primal SF 016, the earth sample was further reinforced by brushing. The aqueous dispersion of acrylic emulsion used for the application was diluted with distilled water for 10 times, and the final solid content was about 5%. Samples were brushed every 15 minutes up to a total of 5 times. Before testing, the earth samples were cured for 3 weeks at room temperature.

Table 4 shows the chromatic alteration of the samples after complete immersion in the consolidating products. For the tested samples, the variation of the chromatic alteration caused by KSE OH300 is the smallest. Among them, the chromatic alteration of sample 1# (earth inside the museum) and 3# (earth from ground surface) is between 0.2 and 0.5. The variation of the chromatic alteration caused by Primal SF 016 is the largest. The chromatic alteration of sample 3# (earth from ground surface) is higher than 8. The chromatic alteration caused by Wacker OH 100 is in between, but the result is also significant. It is important to mention that the surface of the samples consolidated with Primal SF 016 suffers the formation of a high-gloss transparent film. Therefore, Primal SF 016 is obviously not suitable for the consolidation of the Tongguan kiln site.

The product that penetrates inside the sample primarily increases the strength of the sample by filling the voids in the porous structure. The absorption rate can reflect the amount of consolidating product permeating the samples. Generally, the higher the absorption rate, the higher is the consolidating product absorbed. Therefore, the reinforcement effect will be more significant. Table 4 shows that the samples consolidated with KSE OH300 have the highest absorption rate, followed by Wacker OH 100 and Primal SF 016.

The change of surface hardness can also indirectly reflect the reinforcement effect of the consolidation products on the site earth. Consistent with the results of the absorption rate, the surface hardness of the samples completely immersed in KSE OH300 is significantly increased (about 55%), followed by Wacker OH 100 (about 45%). As for Primal SF 016, the surface hardness of the treated samples does not change significantly. The surface water permeability test can be indirectly characterized by the capillary water absorption coefficient and by the surface gas permeability. Table 4 shows that the three products maintain a certain water absorption effect.

Table 4 Sample properties test results after completely immersed reinforcement

Sample name	Consolidation materials	Chromatic alteration ΔE^*	Absorption rate (%)	Surface hardness (HLD)	Capillary water absorption coefficient ($\text{g}\cdot\text{cm}^{-2}\cdot\text{h}$)
1# (earth inside the museum)	Blank	--	--	259	1.02
	KSE OH300	2.72	2.96	417	0.90
	Primal SF 016*	4.07	0.28	253	0.02
	Wacker OH 100	7.85	2.15	411	0.28
2# (earth from the open-air)	Blank	--	--	267	0.31
	KSE OH300	2.58	3.22	395	0.34
	Primal SF 016*	2.02	0.46	250	0.01
	Wacker OH 100	9.45	2.97	319	0.24
3# (earth from ground surface)	Blank	--	--	223	0.24
	KSE OH300	3.72	2.44	362	0.25
	Primal SF 016*	6.24	0.19	220	0.06
	Wacker OH 100	4.92	2.54	359	0.28

It should be pointed out that the Tongguan Kiln site is located in a riverside environment, within 1 kilometre from Xiangjiang River and often washed away by strong rainstorms. Therefore, the damage and erosion resulting from precipitation, fluctuation of groundwater level, and changes in air humidity, are particularly frequent and significant. In order to prevent soil erosion caused by rain-wash, the water resistance test is one of the most important evaluation tests. Table 5 details the water resistance test. Compared to the blank sample, the water resistance of the samples completely immersed and strengthened by the three consolidating products is significantly improved. Among them, the best water-resistance effect is obtained with KSE OH300. After being completely immersed in water for 22 hours, the sample consolidated with KSE OH300 shows only micro cracks on the surface. Until completely immersed for 96 hours, the sample still remained intact overall despite the presence of small amounts of bubbles and microcracks. Consistent with this disintegration feature, the disintegration rate of KSE OH300 treated samples is significantly reduced from 6.5~14.4 g/min to 0.068~0.087 g/min. In contrast, after 2 hours immersion, the coating formed on the surface of the samples consolidated with Wacker OH 100 began to break and cracks. After 24 hours immersion, the surface of the samples looks intact, but the sample have softened and disintegrated. The samples consolidated with Primal SF 016 show a poor water resistance, although a layer of coating is formed on the surface.

Table 5 Water resistance tests on rammed samples

Sample name	Consolidation materials	Weight (g)	Disintegration feature	Disintegration speed (g/min)
1# (soil inside the museum)	Blank	499.16	The sample began bubbling after entering the water. 1 minute later, the bubbling was drastic and the earthen particles collapsed. 4 minutes later, the surface of the sample began to peel off, and became severe after 8 minutes. 10 minutes later, the corner of the sample collapsed and the sample completely disintegrated after 75 minutes.	6.65
	KSE OH300	413.27	Bubbling after entering the water, micro-cracks appeared on the surface of the sample after 22 hours, and the sample remained intact after 96h.	<0.072
	Primal SF 016	483.21	The sample began bubbling after entering the water. After 1 hour, the surface of the sample was broken, and about one third of the sample was cracked after 2 hours. 100 minutes later, the sample completely disintegrated.	4.832
	Wacker OH 100	443.66	The sample began bubbling after entering the water. 2 hours later, micro-cracks appeared on the surface of the sample. 24 hours later, the microcracks on the surface of the sample grew, but the sample still maintained its original shape.	<3.697
2# (soil from the open-air)	Blank	432.39	After entering the water, a few small bubbles appeared. 4 minutes later, the bubbles became more. 6 minutes later, the amount of bubbles became larger, the bubbles became larger and more intense. 10 minutes later, the surface of the sample began to layer up, and after 12 minutes, the layer began to flaking. 16 minutes later, the sample was completely broken into three parts, and completely disintegrated after 30 minutes.	14.41
	KSE OH300	502.41	The sample began bubbling after entering the water. 40 minutes later, cracks appeared on the surface of the sample, and developed into fissures about 1 mm wide, but the sample still remained intact.	<0.087
	Primal SF 016	347.05	No obvious change after entering the water. 2 hours later, the cracks began to appear at the surface of the sample. 24 hours later, the inside of the sample was disintegrated, and the epidermis remained intact, but it had softened.	>2.89
	Wacker OH 100	397.59	The sample began bubbling after entering the water, and a large number of bubbles adsorbed on the surface. 45 minutes later, the microcracks on the surface of the sample began to expand, which resulting in the sample completely broke into two parts within 24 hours.	>397.59

3# (soil from ground surface)	Blank	487.39	After entering the water, tiny bubbles appeared. 2 minutes later, flaking appeared on the surface of the sample, and the particles began to fall off after 5 minutes. 18 minutes later, the sample showed weak disintegration, and the disintegration rate was slow after 30 minutes. 75 minutes later, the main body still didn't completely disintegrate.	<6.50
	KSE OH300	389.67	After entering the water, a few bubbles appeared. 2 hours later, even micro-cracks came up on the surface of the sample; it still remained intact after 96 hours.	<0.068
	Primal SF 016	343.80	No obvious change after entering the water. 2 hours later, the surface of the sample was cracked, and the inside of the sample completely disintegrated after 24 hours, leaving only the outer shell.	0.239
	Wacker OH 100	344.55	The sample began bubbling after entering the water, and a large number of bubbles adsorbed on the surface. 2 hours later, micro-cracks appeared on the surface of the sample. 24 hours later, the micro-cracks grew, but the sample still maintained integrity.	<2.87

CONCLUSIONS

The consolidation treatment carried out on the earth of the Tongguan Kiln site through unilateral penetration and complete immersion reinforcement shows that the treatment with KSE OH300 silicone guarantees good penetration and strengthening together with water resistance. This is a very important aspect considering the humid area and riverside geographical environment that characterizes the site of the Tongguan Furnace. The penetration depth of the product can reach 4cm and the surface strength increases by 40%-50%. After 96 hours of complete water immersion, despite of the occurrence of a small amount of bubbles and microcracks, the samples consolidated with KSE OH300 remain intact as a whole and the disintegration rate is only 0.068-0.087 g/min. In addition, the chromatic alteration caused by KSE OH300 is very small.

BIBLIOGRAPHICAL REFERENCES

- Chen P., Zhang G.H. (2007), "Experimental study on indoor reinforcement to protect the the Great Wall ruins in Yulin", in *Earthquake Engineering and Retrofitting*, 29/3, pp. 30-34.
- He L., Liang G.Z. (2002), "The research of Polyvinylidene fluoride polymer reinforced protection soil relics", in *Dunhuang study*, 6 pp. 92-98.

- Hu X.Q., Wang Y.F., Fan M., Ma Z.H. (2010), "Research progress of Earthen Ruins reinforced material", in *Materials Review (Online Edition)*, 5/4, pp. 11-15.
- Li X.J., Lin J.H., Wan T., Xiao W.B. (2006), "The preparation of a new consolidation material for earthen archaeological site and the evaluation of its effectiveness", in *Journal of Chengdu University of Technology (Science & Technology Edition)*, 33/3, pp. 321-326.
- Li X.J., Wan T., Lin J.H., Xiao W.B. (2009), "Preparation and performance study of the reinforcement material for Jinsha archaeological site", in *Materials science and technology*, 17/2, pp. 215-220.
- Liu S.J., Sun M., Gao F., Xiao Y., Liu K.Y. (2013), "Silica colloid based inorganic-organic hybrid materials for stone monuments conservation and anti-weathering evaluation", in *Journal of Central South University (Science and Technology)*, 44/1, pp. 46-54.
- Sun M.L. (2007), "Study of Protection and Development of the earthen sites", in *Sciences of Conservation and Archaeology*, 19/4, pp. 64-70.
- Sun M.L., Li Z.X., Wang X.D., Shen W.W. (2007), "Classification of deteriorations associate with many earthen heritage sites in arid areas of northwest China", in *Journal of Engineering Geology*, 15/6, pp. 772-779.
- Su B.M., Li Z.X., Hu Z.D. (2000), "Preliminary study on PS and earth relics mechanism of action", in *Dunhuang study*, 1, p. 30.
- Tian S.P., Liu S.J., Gao F., M.F. J. Ren. (2011), "Preparation and assessment of superhydrophobic organic-inorganic hybrid coatings for conservation of Yungang grottoes", in *MRS Proceeding*, edited by Cambridge University Press, Boston, 1319/4, pp. 221-225.
- Yuan C.X. (2002), "Summary of earthen sites protective material earthen sites", in *Dunhuang study*, 6, pp. 108-110.
- Wang Y.M. (2003), "A brief of reinforcement of earth structure sites in the arid areas of Northwest China", in *Journal of Engineering Geology*, 11/2, pp. 189-192.
- Wang X.D. (2008), "New progresses on key technologies for the conservation of Chinese earthen sites in arid environment", in *Dunhuang Research*, 6, pp. 6-13.
- Wang Z., Zhang B. (2009), "Study on reinforcement of earthen sites", in *Earthquake Engineering and Retrofitting*, 31/4, pp. 78-80.
- Zhang H.Y., Li M., Wang X.D., Guo Q.L. (2011), "Moist soil site definition and classification of diseases", in *Dunhuang study*, 6, pp. 70-76.
- Zhao H.Y., Wang X.D., Li Z.X., Han W.F., Guo Q.L., Shen W.W., Wang S.X. (2006), "Impact of modulus and concentration of potassium silicate material on consolidating earthen architecture sites in arid region", in *Chinese Journal of Rock Mechanics and Engineering*, 25/3, pp. 557-562.
- Zhou S.L., Yuan S.X., Yang X.W., Guo B.F. (2003), "The Comparison of several earthen sites weathering effect of reinforcing agent", in *Conservation and Archaeology*, 15/2, pp. 40-48.
- Zhou S.L., Yuan S.X. (2004), "The preparation of non-aqueous dispersion of silicone modified acrylic resin and trial in the conservation of earthen sites", in

- Conservation and Archaeology*, 16/4, pp. 50-52.
- Zhou H., Zhang B.J., Chen G.Q. Zhao H.Y., Zeng Y.Y., Guo Q.L., Li Z.X., Wang X.D. (2008), "Situ protection and reinforcement research about the ancient soil ruins in the humid environment", in *Rock-soil mechanics*, 29/4, pp. 954-962.
 - Zhou H., Zhang B.J., Li Z.X., Wang X.D. (2004), *The waterproof and reinforced protection of the humid environment earthen sites*, in *Proceedings of the third annual meeting of China Association for preservation technology of cultural relics*, edited by The Forbidden City Publishing House, Hangzhou, pp. 47-51.

EARTHEN WALLED VILLAGES IN THE SHANXI PROVINCE: LAONIUWAN (老牛湾) CASE

LAURA GENOVESE¹, LOREDANA LUVIDI¹, ROBERTA VARRIALE², FABIO FRATINI¹
National Research Council of Italy - CNR, Institute for Heritage Science - ISPC, Italy

Keywords: Earthen architecture, walled villages, yaodong, conservation, enhancement

GREAT WALL RURAL SETTLEMENT REGION

The Laoniawan valley (Fig. 1), in Pianguan County, Shanxi Province, for centuries represented the outer limit of imperial rule and there remain portions of the Great Wall, which rises and falls according to the ancient erosion gullies of the earth. Along the mountain ridge, great circular embankments still stand where once beacons were lit to warn of invasion from Mongol horsemen. Here the main long, narrow road circles sweeping mountains, flanks the terraced, green fields interspersed with vernacular rural villages, thus composing a very unique natural and human landscape.



Fig. 1 A view from the Laoniuan Valley to the Yellow River. On the left promontory, there is the ancient Laoniuan Fort and village, on the other, a modern village

The Laoniawan village (Lat. 39 ° 38 '11.71 "N Long. 111 ° 26 '111.66 "E, s.l. 1026 m) is a very ancient one. Since the beginning of XV cent., under the Ming dynasty (1368-1644), it raised as fortification occupying a dominant position on an important landing along the Yellow River, playing a strategic role for the defense of borders and for trade with the Tartars, on the Mongolian side of the river.

Under the Qing dynasty (1644-1912), when emperors no longer stationed troops in Laoniawan Castle, some of the soldiers remained here becoming farmers or retailers, continuing trades to Tartar, and building houses in or near the walls of the fortress. As an increasing number of people moved to Laoniawan, the community grew into a walled village.

Along the road from Laoniawan village to Deshengbao Fortress (Fig. 2) are sited lots of similar settlements, at a distance of about 20 km from each other. That is why they had a defensive role, forming part of the fortification system of the Great Wall, having been built during the Ming dynasty (Knapp, 1992; Linfeng Wang, 2018). This is a widespread defensive system in northern China, from the coast in northeast of Hebei into the Yellow River meander areas, among Inner Mongolia, Shanxi and Shaanxi, an area along the Great Wall known as Great Wall Rural Settlement Region.



Fig. 2 Great Wall Rural Settlement Region: area from Laoniawan village to Deshengbao Fortress. Walled villages area showed with a star

In the late Warring States Period (476 BC-221 BC), many ancient states (Han, Zhao, Wei, Yan, Chu and Qi) built their own defensive wall along their borders to prevent attack from other states. When Qin state conquered those six states, creating the first empire in Chinese history, the different wall sections were put together.

Since then, every dynasty repaired and reinforced the Great Wall until Ming dynasty. Thus, this military defense system consisted not only of the long defensive wall, but also of beacon towers and military settlements where troops were placed.

More precisely, at the beginning of the Ming dynasty, the preliminary role of those settlements was to prevent invasions of northern nomadic tribes. While, in the central period of the Ming dynasty, the commercial function increased. When the Qing dynasty took the place of the Ming dynasty, these fortresses totally lost their military function and became rural villages. Their earthen high walls were partly abandoned having lost their defensive role. Unfortunately, today most of those structures are partially destroyed or disappeared. Nonetheless, in most of the villages' current name is present the word "bao" or "pu" that means it was a defensive castle and "cun" means that it is now a common village.

LAONIUWAN VILLAGE

Today, Laoniawan's historic urban landscape still shows the traditional morphology (Fig. 3). On the top of the hill, the ancient castle walls, made of earthen masonry, are still there in a very poor state (Fig. 5-6). The watchtowers, along the walls, are in pretty much the same state of conservation and so are the keeps on the south side of the wall. The towers were about several hundred meters apart, truncated square pyramids in shape, each one surrounded by a smaller wall, probably constituting the barracks of the Ming soldiers. The main entrance is surrounded by a tower, realized by mixing earthen and local stone.



Fig. 3 Laoniawan village map (A. D'Eredità)

Inside the fortress, one may observe the ancient beacon tower, made of stone basement and fired bricks masonry, which has been used as a granary in modern time, and few dwellings in yaodong (窑洞) style - i.e. with structures dug or

semi-hollow in the ground -, built with few bricks from the walls of the fortification itself. Furthermore, walking on the edges of the rocks contouring the gorge, on a hill about 5 or 6 km NW from Laoniawan, there is a temple area.

Lower down, at the foot of the wall belt, following the irregularity of the topography, some cave dwellings were excavated into flanks of elongated ravines, together with farming terraces, and here there are also stone walls remains subdividing each property (Fig. 4), composing a very peculiar urban shape.



Fig. 4 Laoniawan village, a general view of yaodongs



Fig. 5 Laoniawan Fort remains



Fig. 6 Laoniawan Fort remains

Those cave spaces have varied functions, constituting the minimal unit of innumerable rural villages (Genovese et al., 2019). Depending on the subsoil geo-morphology and the geo-climatic conditions, yaodongs have a variety of plans, sections and details, representing the very expression of the technical skills and traditional culture of the Loess Plateau region (Golany, 1992). This is an area of almost 640,000 km², covering most parts of the provinces of Shanxi and Shaanxi and it extends into parts of Gansu, Ningxia, and Inner Mongolia. The plateau is characterized by slopes, ridges and valleys, with a very fine and loamy terrain that is highly fertile and easy to dig (Kapp, 2015). Despite the easy erodibility, these terrains have the characteristic of being pseudo coherent, i.e. they can be excavated and the cavities are more or less self-sustaining like in the case of volcanic tuff. Moreover, thanks to the pseudo coherent characteristics acquired by mixing with water and then dried, loess has been the material used to build locally the different portions of the Great Wall, fortresses and dwellings according to a particular technology.

Generally, a yaodong is a kind of artificial cave shaped like a long vaulted room, with a semicircular entrance closed by walls, made of earthen bricks, stones of wood, and covered with a wooden door or a quilt. This arch-shaped structure provides the entrance to the dwelling, allowing the sun to penetrate further inside the cave even in winter, therefore making full use of solar radiation. A thick layer of earth on top (about 3 to 5 meters deep) acts as an effective insulation coverage and humidity modulator. Above a yaodong, there are often little chimneys and a tunnel constructed in the earth, representing the breathing system of a yaodong. The inner space has usually a mixed use: the main living room works as well as the kitchen and sometimes

the bedroom. In fact, the brazier for cooking also works as heating for the environment and for the adobe brick bed (*kang*) attached to it. While the toilet is outside of the cave, as an individual unit.

Furthermore, Laoniawan village has different typologies of yaodongs, as semi terrain and independent ones. This last typology - *hoop yaodong* (*gūyáo*) - represent a very local type, having a chamber almost all above ground with an arched structure inspired by the underground dwellings, and facing in a courtyard. This arch-shaped structure realized in stone, and covered with an earthen plaster for thermal insulation purposes, also provides the entrance to the dwelling. Walls are built with earthen bricks and/or stone flakes, while roofs are made of stone flakes covered with earth, to ensure the thermal insulation of the interiors.

Those types of yaodongs depend on ground morphology: the presence of the bedrock exposed on top of the hill makes excavation somewhat difficult and motivates the construction of houses wholly above ground, while if these insist on the slope of the hill they are partially excavated.

Usually multiple dwellings are built adjacent to or on top of one another and connected together to form a multi-tiered village, often for a single clan or an extended family. Terrain and semi terrain elements are combined with structure built above ground in order to form an integrated complex connected by path (Knapp, 2000). Nonetheless, dwellings are hidden in the environment, being perfectly integrated into nature with minimum impact. However, they are very fragile: earthen architecture is subject to rapid decay processes, particularly suffering the humidity, thus needing daily maintenance.

EARTHEN WALLED VILLAGES AND CONSERVATION ISSUES

In Laoniawan village, the main activity of the dwellers was farming, and they were isolated from the rest of the world. In recent years, many of the residents have moved to big cities in search of work. Now, very few people still live in Laoniawan village. In recent years, the Government has planned the reconstruction and restoration of vernacular structures using local materials and traditional knowledge to reuse these dwellings with the goal of local development through a sustainable tourism. Laoniawan has been faced with the challenge of not losing its vitality, safeguarding its environment and culture, by attracting tourism.

Nonetheless, the conservation problem still remains. Rammed earth is the main construction technique of the large rammed earth mound walls that encircled villages in the Shanxi Province. Rammed earth is a construction technique where the soil is taken from the ground and compacted to form structures. Removable formwork is installed, and the soil compacted within it. This technique was widely used in ancient constructions. The term "hangtu" is used by Chinese archaeologists to describe both rammed earth mounds and earth rammed between formwork (Jaquin,

2008). For earthen sites, exposed outdoors two main deterioration factors can be distinguished: natural and human. The human factor is due to technique of construction and engineering-related properties of the materials selected to build the site. The natural factor is due to rain, wind, solar radiation, mudslides, biological action etc. and they cause physical and chemical weathering (Li, 2009; Wang, 2004; Li, 2011; Du, 2017).

Chemical deterioration is mainly due to enrichment of soluble salts that cyclically dissolve and crystallize leading to the destruction of cohesive forces and the erosion of earthen material. Physical weathering is erosion by wind and rain. In arid climates, precipitations are generally low but heavy, they contribute significantly to erosion, as they soften and disintegrate the earth. Especially in summer season, the high temperature promotes a high evaporation rate of the water leading to quickly drying the earthen surface and turns the softened earthen material into scale like crusts, which fall off under the combined action of wind and rain.

The following types of decay can be observed in earthen structure: erosion, exfoliation, honeycomb, scaling off (Cui, 2019), sapping, gulling, cracking, collapse and biodeterioration. Among these types of deterioration, exfoliation, cracking and erosion are the most frequent because wind and severe rainfall are the main impact factors of decay. All these types of decay mechanisms can threaten the stability of the earthen site.

According to the "Principles for the Conservation of Heritage Sites in China", conservation intervention refers to all measures carried out to preserve the physical remains of sites and their authenticity. The conservation involves the identification and investigation of heritage sites for determining the values of a site, its state of preservation, and its management context through analysis of historical documents and on-site survey. Only if because of the previous investigation the site is formally proclaimed as an officially protected entity the preparation of a preservation master plan is carried out. The first step of the conservation practice is the routine maintenance to slow deterioration and only if the site is considered at risk of heavy damage the "minimal" conservation intervention is planned (Agnew, 2002).

The consolidation techniques for earthen sites include surface consolidation (Li, 1995, 2009, 2011; Zhou, 2004; Wan, 2012; Zhao, 2016; Wang, 2016), grouting, mud bricklaying, anchor bamboo or wooden rods, and building a new wall where the wall collapsed.

In the area of the walled villages investigated in this contribution, the remains of the rammed earth walls are affected by various climate-related conservation problems. In fact, in the area the rains are few but intense. Most of the rain falls in the summer period, in two months, when the temperatures are very high with consequent rapid evaporation, which leads to the formation of cracks, exfoliation, honeycomb, sapping until the collapse of the foundation. The dry but very windy winter favors a strong superficial erosion. In addition, the presence of vegetation favors phenomena of disintegration.

These problems, together with a total lack of maintenance, are leading to the complete destruction of the rammed earth walls of the villages. Therefore, an immediate action is necessary both to assure structures at risk of collapse and to preserve existing structures with surface and structural conservation methods with attention to the construction of drainage systems for rain.

CONCLUSIONS

The conservation and enhancement of the earthen military villages should be associated with the protection of the rural landscape as required by the Venice Charter (1964, article 1) which underlines the concept of conservation of historical monuments but also the urban or rural setting in which is found the evidence of a particular civilization. In recent decades, the Chinese government has paid much attention to the protection and restoration of the Great Wall and has implemented the "Great Wall Protection Ordinance" in 2006, which outlines actions concerning natural factors and human activities that seriously threaten the structure of the Great Wall (last updated on 22 September 2017).

Tangible results of this activity are highlighted in the village of Laoniawan located near the Great Wall in Shanxi Province. Furthermore, the series of Ming dynasty military settlements, whose inhabitants are currently farmers, have not received the same attention or only in some cases, there are examples of projects for the conservation and maintenance of the characteristics of their vernacular architecture.

A reasonable solution should be a common strategic plan for conservation projects and reconstruction of earthen walled settlements that takes into account the entire minor sites as well as the rural landscape. Only this more global vision will allow local development by promoting awareness among the inhabitants of local villages of the intrinsic values of their heritage. The Sino-Italian collaborative research still ongoing by the authors on vernacular earthen villages, about which some results are reported in this paper, aims at evaluate possible solutions for conservation and sustainable enhancement of structures and landscapes.

REFERENCES

- Agnew, N., Demas, M. (2002), *Principles for the Conservation of Heritage Sites in China*, Los Angeles.
- Cui, K., Du, Y., Zhang, Y., Wu, G., Yu, L. (2019), An evaluation system for the development of scaling off at earthen sites in arid areas in NW China. *Herit Sci* 7: 14. <https://doi.org/10.1186/s40494-019-0256-z>.
- Du, Y., Chen, W., Cui, K., Gong, S., Pu, T., Fu, X. (2017), A Model Characterizing Deterioration at Earthen Sites of the Ming Great Wall in Qinghai Province,

- China Soil Mech Found Eng (2017) 53: 426. <https://doi.org/10.1007/s11204-017-9423-y>.
- Genovese, L., Varriale, R., Luvidi, L., Fratini, F. (2019), Italy and China Sharing Best Practices on the Sustainable Development of Small Underground Settlements. *Heritage* 2(1), pp. 813-825. Available online: <https://www.mdpi.com/2571-9408/2/1/53> (accessed on May 31, 2019).
 - Golany, G.S. 1992. Chinese Earth-Sheltered Dwellings: Indigenous Lessons for Modern Urban Design. Honolulu, pp. 66-108.
 - Jaquin, P.A., Augarde, C.E., Gerrard, C.M. (2008), Chronological Description of the Spatial Development of Rammed Earth Techniques. *International Journal of Architectural Heritage*, 2:4, pp. 377-400, DOI: 10.1080/15583050801958826.
 - Jiaping, L., Wang, G. & Liu, Y (2002). An Instance of Critical Regionalism: New Yaodong Dwellings in North-Central China. *TDSR*, v. XIII, n. 2, pp. 63-70.
 - Kapp, P., Pullen, A., Pelletier, J.D., Russell, J., Goodman, P., Cai, F. (2015). From dust to dust: Quaternary wind erosion of the Mu Us Desert and Loess Plateau, China. *Geology* (43), pp. 835-838.
 - Knapp, R.G. ed. (1992), *Chinese Landscapes: The Village As Place*, Honolulu.
 - Knapp, R.G. 2000. *China's Old Dwellings*, Honolulu.
 - Li, Z., Zhang, H., Wang, X. (1995), Reinforcement of ancient earthen structures. *Dunhuang Studies* 3, pp. 1-18.
 - Li, Z., Zhao, L., Sun, M. (2009), Deterioration of earthen sites and consolidation with PS material along Silk Road of China. *Yanshilixue Yu Gongcheng Xuebao/Chinese Journal of Rock Mechanics and Engineering*. 28, pp. 1047-1054.
 - Li, Z., Wang, X., Sun, M., Chen W., Guo, Q., Zhang, H. (2011). Conservation of Jiaohu ancient earthen site in China, *Journal of Rock Mechanics and Geotechnical Engineering*, Volume 3, Issue 3, 2011, pp. 270-281. <https://doi.org/10.3724/SP.J.1235.2011.00270>.
 - Linfeng, W. 2018. Spatial analysis of the Great Wall Ji Town military settlements in the Ming Dynasty: research and conservation, *Annals of GIS*, Vol. 24, 2, pp. 71-81.
 - Lu, Y.ed. (2015), *A History of Chinese Science and Technology*, Vol. 3, Heidelberg.
 - Wan, T., Lin, J. (2014), A new inorganic-organic hybrid material as consolidation material for Jinsha archaeological site of Chengdu J. Cent. South Univ. 21: 487. <https://doi.org/10.1007/s11771-014-1965-9>.
 - Wang, X., Li, Z., Zhang, L. (2004), Condition, Conservation, and Reinforcement of the Yumen Pass and Hecang Earthen Ruins near Dunhuang. In "Conservation of Ancient Sites on the Silk Road", Proceedings of the Second International Conference on the Conservation of Grotto Sites, Mogao Grottoes, Dunhuang, People's Republic of China, June 28-July 3, 2004, Edited by Neville Agnew, pp. 370-377.
 - Wang, X., Guo, Q., Yang, S., Zhang, D., Wang, Y. (2016), Nondestructive testing and assessment of consolidation effects of earthen sites. *Journal of Rock Mechanics and Geotechnical Engineering*, Volume 8, Issue 5, 2016, pp. 726-733. <https://doi.org/10.1016/j.jrmge.2016.06.001>.
 - Zhang, Y., Li, X., Song, W., Zhai, L. (2016). Land abandonment under rural

- restructuring in China explained from a cost-benefit perspective, in *Journal of Rural Studies* 47, pp. 524-532.
- Zhao, D., Lu, W., Wang, Y., Mao, X., Ai, Y., Jiang, H. (2016), Experimental Studies on Earthen Architecture Sites Consolidated with BS Materials in Arid Regions, *Advances in Materials Science and Engineering*, vol. 2016, p. 13. <https://doi.org/10.1155/2016/6836315>.

RAW EARTH ARCHITECTURE IN SARDINIA: SULCIS AS A CASE STUDY

MARCO BIANCHI¹, MASSIMO BOTTO², PAOLO PASCİ³

¹ Polytechnic University of Milan, Department of Architecture, Milan – Italy

² CNR – “Institute of Heritage Science” (ISPC) – Rome – Italy

³ Territorial Museum of Scattered Settlements Association – Cagliari – Italy

Keywords: Phoenician colonization, Raw Earth, Sardinia, Sulcis, Medau, Furriadroxiu

INTRODUCTION

Raw earth buildings have been built and are still present throughout Italy (Achenza, Cocco 2015), but Sardinia, more than any other part of the country, has retained the characteristics of its pre-industrial agro-pastoral culture, preserving a large number of raw earth settlements that demonstrate the continuing historical use of this material for building (Angioni, Sanna 1988; Melis, Albero Santacreu 2017, with bibliography).

The following paper analyses the situation in Sulcis, an area located in the southwest of the island. An association, the “Museo diffuso dell’insediamento sparso” (“Territorial Museum of Scattered Settlements”, hereafter “Territorial Museum”), founded in Santadi, has the aim of conserving and promoting settlements built using mixed techniques – i.e. using both stone and adobe – which are known as *furriadroxiu* and *medaus* (Sanna, Cuboni 2008).

The earliest documented use of raw earth as a building material is found in the Pre-Pottery Neolithic B (9600-8000 BP) context of Jericho in the Near East (Aurenche 1981). In Sardinia adobe has been used by the local population since the Neolithic/Chalcolithic. For example, it has been identified by archaeologists in the village of Su Coddu/Canelles (Selargius, Cagliari) (3400-2850 BP), in southern Sardinia (Melis 2010; Melis, Albero Santacreu 2017). Adobe and rammed earth floors can also be found in Nuragic contexts from the Bronze and Iron Ages. Two cited cases are those of Su Cungiau ‘e Funtà and Nuraghe Pidighi, both in the Oristano province, in the central-west of the island (Sebis 2007; Usai 2013). Other earthen architectures are from Santa Anastasia of Sardara, Monte Olladiri, Monte Zara of Monastir and San Sperate, in southern Sardinia (Ugas, Usai 1987).

Earthen architecture accompanied the Phoenicians as they spread towards the central-west Mediterranean and the Atlantic from the 9th century BC (Aubert 2001; Bondi et al. 2009). It has been found in all areas colonized by the Phoenicians. In North Africa most evidence comes from Carthage, while in Spain it is found in Mediterranean Andalusia, e.g. at Morro de Metzquitilla and La Rebanadilla (Jaquin et al. 2008; Sánchez Sánchez-Moreno et al. 2018, fig. 2). Furthermore, in Cadiz, on the Atlantic side, recent excavations have produced some very interesting results (Gener Basallote et al. 2014). In Sardinia, the technique of building adobe walls on a stone foundation has been found in all areas settled by the Phoenicians. In Sulcis, for example, this technique already existed in the earliest phases of Phoenician colonization.

Sulky, the first Phoenician settlement in Sulcis (Fig. 1), was founded on the island of Sant'Antioco in the first half of the 8th century BC, and the excavations in the settlement have led to the discovery of covered square rooms flanked by courtyards, arranged at right angles (Unali 2017).

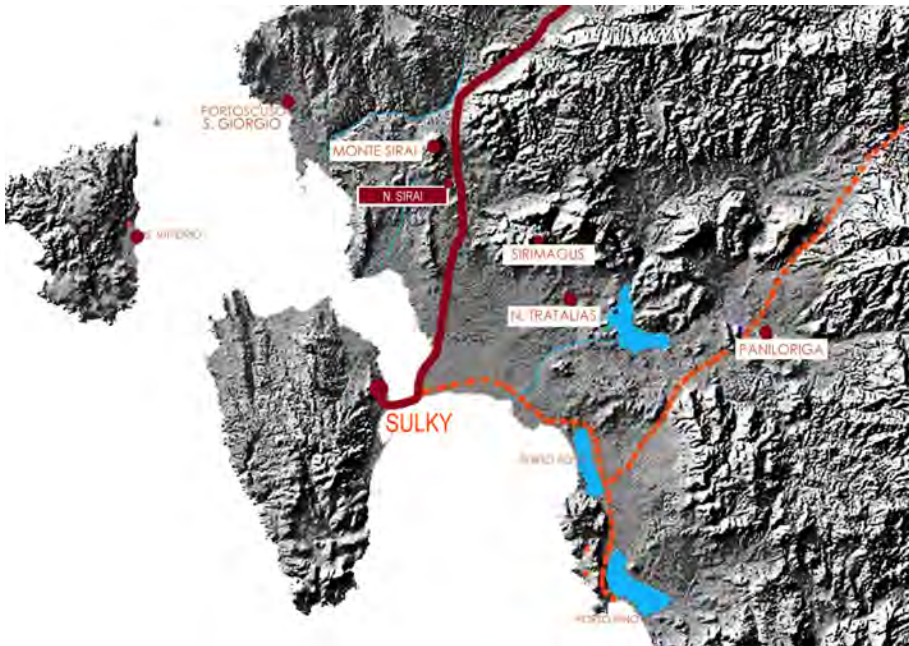

Fig. 1 Phoenician and Punic Sulcis (Perra 2013)

These rooms were built using medium and small-sized stones, bound with a mud binder and forming the base of an adobe wall, while the floors were made of rammed earth. As early as the second half of the 8th century BC, there was a movement of people from Sulky towards the hinterland, leading to the control of large parts of Sulcis being shared with the local population (Botto et al. 2014). The building

techniques that the Phoenicians used in Sulky have also been found in the newly established centres such as Monte Sirai (Guirguis 2013), the fortress at Nuraghe Sirai (Perra 2018) and Pani Loriga. Concerning the last site, the excavations carried out by the Institute for Studies on the Ancient Mediterranean (CNR – ISMA) from 2006 (Botto et al. 2010) have revealed a settlement founded by the Phoenicians at the end of the 7th century BC, which reached a considerable size at the beginning of the 5th century BC, following the military occupation of some parts of Sardinia by Carthaginians (Botto et al. 2016; Botto 2017).

Pani Loriga hill rises above the nearby settlement of Santadi, where the “Territorial Museum” operates. The long experience that the ISMA team has gained through its many years of excavation at Pani Loriga has been of fundamental importance in reconstructing the history of earthen building across the territory. This has led to a close collaboration between the archaeologists working at Pani Loriga and the members of the “Territorial Museum” association to promote common projects for the safeguarding and promotion of raw earth structures in Santadi and the surrounding areas.

THE “TERRITORIAL MUSEUM” ASSOCIATION

The association aims to help the people living in Sulcis to rediscover their past identity and cultural heritage through the safeguarding and promotion of places and landscapes of historical interest. By making this heritage visible, the “Territorial Museum” has defined new spaces for art, learning, knowledge, residential use and improved quality of life. Furthermore, the visibility of cultural objects and their new “uses” can help make residents more aware of the advantages of safeguarding and promotion by involving them in such activities. The mission of the “Territorial Museum” is to make the local culture better known and more appealing to people and to disseminate new evidence and research through a variety of communication channels. The “Territorial Museum” encourages the development of thematic itineraries throughout the territory by involving existing museums. The final aim is to create a network of museums and culturally interesting places through the development of a region that has much to offer both culturally and economically.

As mentioned above, the “Territorial Museum” covers the whole of Sulcis, but in this first phase it operates around Santadi. As part of its activities, the “Territorial Museum” is working to halt the continuing degradation of historical scattered settlements. The model is that of “minimum-cost” interventions, which involve cleaning the buildings or objects and making them secure and visible. Promotion, on the other hand, is carried out through the restoration of the settlements to their original use.

One way in which the “Territorial Museum” is making the archaeological and cultural heritage of Sulcis better known is through a website (www.museodiffuso.org). Other organizations operating throughout the territory are the Autonomous Region of Sardinia (Regione Autonoma della Sardegna), research centres, universities and

the “Earthen Cities” (www.terracruda.org) national association, which focuses on earthen housing and to which the “Territorial Museum” makes explicit reference in its activities.

THE SCATTERED SETTLEMENT

Sardinian scattered settlements are very ancient and can be found across the whole territory. They are generally of an agro-pastoral nature and used as dwellings for individuals or groups of people linked by family or community. These communities produced a multi-centred system of scattered settlements located near the main resources. This is a process that started during the later Middle Bronze Age (15th-14th centuries BC) and intensified during the following Recent and Final Bronze Ages (12th-10th centuries BC). The scattered settlement reached its zenith with the Nuragic culture and is identified with its greatest architectural expression, the *nuraghe*, which is found throughout the Sardinian landscape. Scattered settlements continued to exist after the *nuraghi* ceased to be built and were mostly abandoned. With the Early Iron Age (930-730 BC), the reorganization of the Nuragic communities is shown by the development of villages, temples and sanctuaries (Usai 2015). In this phase, the interactions between the local populations and the Phoenicians and the opening of the island to international trade led to the exploitation of the territory’s resources and brought about a reorganization of the connections between the coastal areas – where the first urban centres developed – and the inland areas.

Scattered settlements have survived in the inland areas of Sardinia up to modern times, when we have the first indications of rural structures known as *furriadroxius* and *medaus* (Mistretta 1966; Sanna et al. 2008).

The *furriadroxius* and *medaus* are small, rural, agro-pastoral settlements, usually built in raw earth, which can accommodate a limited number of interrelated families. *Furriadroxius* and *medaus* are both well-defined and easily identifiable types of scattered settlement: the former are one-storey shelters or dwellings for arable farmers; the latter are two-storey houses for pastoral farmers. The *furriadroxius* were the typical type of house in Sulcis until the mid 1990s, but at the same time they look back to what must have been the organizational and social structures of the Nuragic people.

In Sulcis, the scattered settlement was partially abandoned in the first decades of the 19th century, with the start of the mining industry and the creation of utopian “mining cities”, to which a good part of the local population moved (Peghin, Sanna 2009). It is interesting to note that, even as the economy changed from agriculture to industry, the new living spaces, particularly the smaller mines of Rosas (Narcao) and Orbai (Villamassargia), continued to use traditional construction methods, and raw earth allowed for the creation of a new type of settlement system: the mining *furriadroxius*. These buildings are different because, although they were built in raw earth, they were constructed near the mines, rather than near the *nuraghi* or in the

agro-pastoral areas. The mining *furriadroxius* demonstrates that such settlement patterns and traditional techniques continued to be employed independently of the type of economy (farming, mining) to which they were linked.

Nowadays the *furriadroxius* and *medaus* have mostly been abandoned, although several settlements are still in use. Intervention has now become urgent, because earthen buildings rapidly disintegrate if not constantly maintained.

The Sardinian Regional Landscape Plan (Regional Law No. 8 of 25 November 2004) considers the “scattered settlement” system to be an aspect of territorial development. In particular, the *medaus* and *furriadroxius*, which are concentrated in the Sulcis area, represent a historical/cultural resource to be safeguarded and promoted.

RAW EARTH

Raw earth as a historical building material (Sanna, Atzeni 2007) – together with its processing, use and end products – is currently being studied as a means to promote the economic development of the territory through its cultural heritage. The use of raw earth can be studied not only for the recovery and restoration of historic buildings (as envisaged in current planning) but also for the construction of new buildings, which would have the advantage of being eco-friendly and improving quality of life (Minke 2000; Mileto et al. 2012; Gauzin – Müller 2017). In the district of Sulcis, such activities join others that have already been planned or are being planned for the development of new methodologies and bio-building products, which use natural substances such as algae, straw, flax, cork and sheep’s wool as inert materials that improve the mixture’s performance (Sanna 1993; Cuboni, Sanna 2013).

Thanks to private funding, the “Territorial Museum” has started to rebuild and renovate in raw earth, creating renewed interest both in this material and in the scattered settlements themselves. Further interest is created by the fact that *nuraghi*, *furriadroxius* and *medaus* are usually found in upland areas of outstanding natural beauty, where they might be used as either permanent or touristic dwellings.

So far, the restoration of earthen buildings has been carried out by the “Territorial Museum” by reusing local materials. In Sulcis, the alluvial deposits of gravel, sand, silt and clay, or loose earth can be found in all the valleys of the area. These materials have been used to produce mud bricks (adobe). All the settlements discussed – both urban and scattered – are ancient, and in all of them walls made of stone and of raw earth coexist. The size of the mud bricks (known in Sardinia as *ladiri*) and the building techniques associated with them were progressively standardized, demonstrating that such methods were the result of island-wide cultural sharings, especially in the intensively cultivated central-south plains. Thus, the standardization of the mud brick might be linked to the relationships between Sulcis and its bordering communities. *Ladiri* are made by combining earth with vegetal fibres, sometimes with the addition of lime, in varying proportions, depending on the type of earth used. The resulting

mixture is cast in a wooden formwork to create a rectangular block with a ratio of 1:2:4 (usually 10 x 20 x 40 cm). The mixture is then sun-dried. The materials used to make the *ladiri* are all sourced locally. Clay is often used to plaster the walls, which need to be protected from the rain to prevent them from disintegrating (Houben, Guillaud 1994; Achenza 2003; Achenza, Sanna 2009).

THE RAW EARTH WORKSHOP

The “Territorial Museum” intends to set up a raw earth workshop that can meet the Museum’s own production needs. The workshop is envisaged as a production and visitor site, an active part of the “Territorial Museum”, with the capacity to stimulate interest and increase demand for raw earth products, supplying materials not only for its own projects, but also for ongoing recovery and restoration works throughout Sulcis. The aim is to encourage the growth of a new architecture in raw earth, not least because of the material’s high thermal insulation properties and the energy savings that can be achieved by using it. The raw earth future workshop will therefore be a place where research will focus both on past history and on construction methods of the future. Indeed, the intention is that within the workshop new products for bio-architecture will be developed, as well as new forms of earth brick.

RAW EARTH RESTORATIONS

One of the activities of the “Territorial Museum” has been to restore four raw earth buildings (two *furriadroxius* and two *medaus*) in Santadi and Nuxis. These buildings will be used for museum activities and, together with other historical *furriadroxius* and *medaus* found in the territory that have been identified as places of interest by the “Territorial Museum” (www.Sulcis.eu), will be a showcase for Sardinia’s forgotten heritage (Fig. 2).

Sa domu ‘e Paxi

The “Sa Domu ‘e Pasc” (House of Peace), the headquarters of the “Territorial Museum”, stands opposite the Archaeological Museum in Santadi and was built using mixed techniques: the foundations in stone and earth, and the walls in *ladiri*. With the aim of enhancing the structure, the house, which dates back to the end of the 19th century, has been restored to its original residential function. Most of the restoration work has been carried out using traditional techniques and materials, respecting centuries-old construction methods. The raw earth walls have been restored by consolidating the pre-existing ones. The “Territorial Museum” has kept all the photographic documentation of the various phases of the work and restoration (Figg. 3, 4, 5).

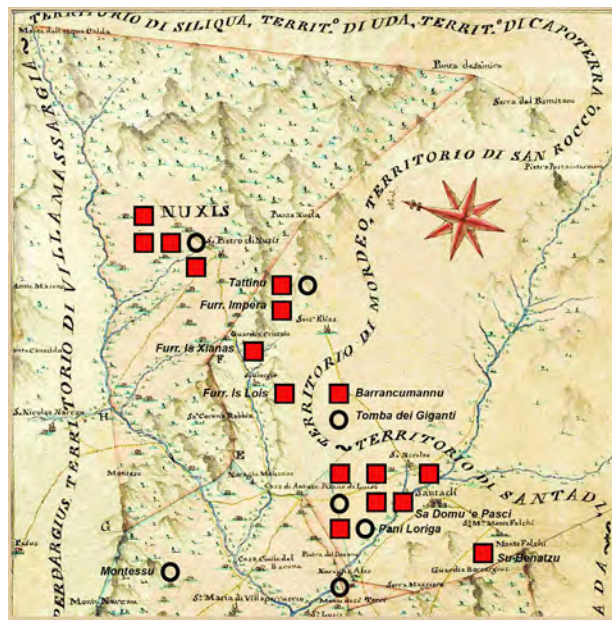

Fig. 2 Map of the places of interest of the "Territorial Museum" (including the completed restorations); those in and around Santadi are marked in red (adapted from Maina's map, unpublished)



Fig. 3 Sa Domu 'e Pasci, Santadi (SU), exterior of building before restoration (Photo Paolo Paschi)



Fig. 4 Sa Domu 'e Pasci, Santadi (SU), internal courtyard before restoration (Photo Paolo Pasci)



Fig. 5 Sa Domu 'e Pasci, Santadi (SU), exterior of building after restoration (Photo Paolo Pasci)

Medau Palatini

The *medau Palatini* is located at Is Lois at Santadi. Built mostly of raw earth, and having been abandoned for years, the *medau* was literally being washed away by the rain. As the damage progressed, so did its degradation. The rainwater had opened a breach of over 50 cm in the raw earth wall, near the corner of the building on the first floor, causing the partial collapse of the roof and putting the whole building at risk of collapse (Fig. 6). The walls in *ladiri*, having been appropriately shored up, have now been cleaned and repaired using local earth. Iron rods were added to ensure stability, as documented in other similar restorations (Fig. 7).



Fig. 6 Medau Palatini, Is Lois, Santadi (SU), detail of exterior of building before restoration
(Photo Marco Bianchi)



Fig. 7 Medau Palatini, Is Lois, Santadi (SU), exterior of building after restoration
(Photo Marco Bianchi)

Raw earth ovens

Part of the "Territorial Museum's" promotion of Sulcis's cultural heritage has been both to conserve the scattered settlements' characteristic raw earth ovens and to maintain a centuries-old tradition, still widely used in Sulcis. Wood-fire baked bread is one of the territory's typical products. *Cocoi* and *civraxiu*, two traditional types of bread from Sulcis, communicate a tradition that is deeply rooted and renewed every day. Indeed, bread and oil are two products that lie at the heart of annual popular festivals. During these events, the Santadi Ethnographic Museum, which is also built in the *furriadroxius* tradition of earth and stone, lights its oven.

Raw earth ovens are particularly important to the "Territorial Museum" as they are places where people come together. With the restoration of the *Is Xianas* and *Tattinu de basciu* ovens (Fig. 8), and those of the *Sa Domu 'e Paxi* and *Is Lois* (Fig. 9), the "Territorial Museum" has been able to demonstrate how quickly and easily ovens can be made from earth and straw. Renovating a raw earth oven may be a small act, but it is one that is very important in safeguarding the local cultural heritage. While from an economic point of view the cost of renovating an oven is minimal compared to that of restoring a whole settlement, in cultural terms it has great symbolic significance.



Fig. 8 Medau Tattinu de basciu, Nuxis (SU), raw earth oven during restoration
(Photo Marco Bianchi)



Fig. 9 Medau Palatini, Is Lois, Santadi (SU), adobe oven (Photo Marco Bianchi)

BIBLIOGRAPHICAL REFERENCES

- Achenza, M. (2003), "The Use of Adobe in the Traditional Buildings of Sardinia. Typological and Construction Innovation between XIX and XX Century", in *Proceedings of the First International Congress on Construction History*, I, Instituto Juan de Herrera, Madrid, pp. 101-111.
- Achenza, M., Cocco, C. (2015), "A Web Map for Italian Earthen Architecture", in C. Mileto, F. Vegas, L. Garcia, V. Cristini, *Earthen Architecture. Past, present, future*, CRC Press Taylor & Francis Group, London.
- Achenza M., Sanna U. (eds.) (2009), *Il manuale tematico della terra cruda, caratteri, tecnologie, buone pratiche*, DEI Tipografia del Genio Civile, Roma.
- Aubet M^e.E. (2001), *The Phoenicians and the West. Politics, Colonies, and Trade*, Cambridge University Press, New York 2001².
- Aurenche O. (1981): *La maison orientale. L'architecture du Proche Orient ancien des origines au milieu du IV^e millénaire*, Édition Geuthner, Paris.
- Angioni G., Sanna A. (1988), *L'architettura popolare in Italia. Sardegna*, Laterza, Rome-Bari.
- Bondì S.F., Botto M., Garbati G., Oggiano I. (2009), *Fenici e Cartaginesi. Una civiltà mediterranea*, Istituto Poligrafico e Zecca dello Stato, Rome.
- Botto M. (2017), "The Punic settlement of Pani Loriga in the Light of Recent Discoveries", in *Fasti Online Settlement and Research* (www.fastionline.org/docs/FOLDER-it-2017-393.pdf).

- Botto M., Dessena F., Finocchi S. (2014), "Indigeni e Fenici nel Sulcis: le forme dell'incontro, i processi di integrazione", in *Materiali e contesti nell'età del Ferro sarda*. Atti della Giornata di Studi Museo Civico di San Vero Milis, eds. by P. van Dommelen, A. Roppa, Fabrizio Serra Editore, Pisa-Roma, pp. 97-110.
- Botto M., Candelato F., Oggiano I., Pedrazzi T. (2010), "Le indagini 2007-2008 all'abitato fenicio-punico di Pani Loriga", in *Fasti Online Documents and Research* (www.fastionline.org/docs/FOLDER-it-2010-175.pdf).
- Botto M. ed. (2016), *Il complesso archeologico di Pani Loriga*, Carlo Delfino Editore, Sassari.
- Cuboni F., Sanna A. (2016), *Caratteri architettonici e costruttivi dell'edilizia storica a Cagliari-Castello. Materiali per un manuale del recupero*, Cangemi Editore, Rome.
- Gauzin-Müller D. (2017), *Earthen Architecture Today (Expanded Edition)*, MUSEO Editions, Plaisan.
- Gener Basallote J.-Ma, Jurado Fresnadillo G., Pajuelo Sáez J.-M., Torres Ortiz M., (2014): "Arquitectura y urbanismo de la Gadir fenicia: el yacimiento del "Teatro Cómico" de Cádiz", in *Los fenicios en la Bahía de Cádiz. Nuevas investigaciones*, by M. Botto (ed.), Fabrizio Serra Editore, Pisa-Roma, pp. 14-50.
- Guirguis M. (2013), *Monte Sirai. 1963-2013 mezzo secolo di indagini archeologiche*, Carlo Delfino Editore, Sassari.
- Jaquin P.A., Augarde C.E., C.M. Gerrard (1987), "Chronological Description of the Spatial Development of Rammed Earth Techniques", in *Journal of Architectural Heritage*, 2,4, pp. 377-400.
- Houben H., Guillaud H. (1994), *Earth Construction: a Comprehensive Guide*, Intermediate Technology Publications, London.
- Maina G. (unpublished), *Cabreo delle baronie che compongono la diocesi del vescovo di Iglesias*, Biblioteca Universitaria di Cagliari (Catalogo dei manoscritti 1891. Inventario Baille).
- Melis M.G. (2010), "L'architecture domestique en Sardaigne (Italie) entre la fin du Néolithique et le Chalcolithique", in *Neolithic and Chalcolithic Archaeology in Eurasia: Building Techniques and Spatial Organisation*, ed. by D. Gheorghiu, Archaeopress, Oxford.
- Melis M.G., Albero Santacreu D. (2017), "Archaeometric Analysis of Wall Coatings from the Chalcolithic Site of Su Coddu (Sardinia, Italy)" in *Mediterranean Archaeology and Archaeometry*, 17, 3, pp. 191-200.
- Mileto C., Vegas F., Cristini. V. (eds.) (2012), *Rammed Earth Conservation*, Taylor & Francis, London.
- Minke G. (2000), *Earth Construction Handbook. The Building Material Earth in Modern Architecture*, WIT Press, Boston.
- Mistretta P. (1966), *Un singolare fenomeno di convivenza in Sardegna*. Atti e Rassegna Tecnica della Società Ingegneri e Architetti in Torino, Stamperia Artistica Nazionale, Torino, pp. 350-366. https://digit.biblio.polito.it/2966/1/10_otto-bre.pdf.

- Peghin G., Sanna A. (2009), *Carbonia Città del Novecento*, Skira editore, Milano.
- Perra C. (2014), *Nuovi elementi per la definizione del sistema insediativo sulcitano dalla fortezza del nuraghe Sirai*, in *Materiali e contesti nell'età del Ferro sarda*. Atti della Giornata di Studi Museo Civico di San Vero Milis, eds. by P. van Dommelen, A. Roppa, Roma, pp. 115-133.
- Perra C. (2018), *La fortezza sardo-fenicia del Nuraghe Sirai (Carbonia). Il Ferro II di Sardegna*, CNR Edizioni, Roma.
- Sánchez Sánchez-Moreno V.-M., Galindo San José, L., Juzgado Navarro, M., Belmonte Marín, J.-A. (2018), "La Rebanadilla, santuario litorale fenicio en el Sur de la Península Ibérica", in *De Huelva a Malaka. Los fenicios en Andalucía a la luz de los descubrimientos más recientes*, ed. by M. Botto, CNR Edizioni, Roma.
- Sanna A. (1993), *Architetture in terra, tipologia, tecnologia, progetto*, CUEC Editrice, Cagliari.
- Sanna A., Atzeni C. (2007), *Architettura in terra cruda dei Campidani, del Cixerri e del Sarrabus. I manuali del recupero dei centri storici della Sardegna*, DEI Tipografia del Genio Civile, Cagliari.
- Sanna A., Cuboni F. (2008), *L'edilizia diffusa e i paesi, il Sulcis e l'Iglesiente. I manuali del recupero dei centri storici della Sardegna*, DEI Tipografia del Genio Civile, Cagliari.
- Sebis S. (2007), "I materiali ceramici del villaggio nuragico di Su Cungiau 'e Funtà (Nuraxinieddu-OR) nel quadro dei rapporti fra popolazioni nuragiche e fenicie", in *Sardinia, Corsica et Baleares Antiquae*, 5, pp. 63-86.
- Ugas G., Usai A. (1987), "Nuovi scavi nel santuario nuragico di S. Anastasia di Sardara", in AA.VV., *La Sardegna nel Mediterraneo tra il secondo e il primo millennio a.C.*, Amministrazione Provinciale di Cagliari. Assessorato alla Cultura, Cagliari, pp. 167-218.
- Unali A. (2017), *Sulky – Sant'Antioco*, in *La Sardegna fenicia e punica. Storia e materiali*, ed. by M. Guirguis, Ilisso Edizioni, Nuoro, pp. 129-137.
- Usai A., (2013), "L'insediamento del Nuraghe Pidighi di Solarussa (OR). Scavi 1998-2008", in *Quaderni*, 24, pp. 3-39.
- Usai A., (2015), "Paesaggi nuragici", in *L'isola delle torri. Giovanni Lilliu e la Sardegna nuragica*, ed. by M. Minoja, G. Salis, L. Usai, Carlo Delfino, Sassari.



PAST AND PRESENT OF THE EARTHEN ARCHITECTURES IN CHINA AND ITALY

The Bilateral project "Assessment of innovative methods for the conservation of earthen surface" was financed by the National Research Council of Italy (CNR) and the Chinese Academy of Cultural Heritage (CACH) for the period 2016-2018. The research undertaken by the two teams aimed to promote a better knowledge of the earthen architecture in China and Italy, exchange and sharing of experiences about methods, tools, protocols and best practices for the conservation of earthen materials. This fragile architecture, due to the poor durability of earthen materials against atmospheric agents, is in a situation of great risk considering also the problem of climate change

This book examines the historical use of this material for architecture, the different types of earthen construction in Italy and in China, the conservation techniques used in the respective countries and the researches that are being carried out to improve these interventions. New opportunities that the earthen architecture can have in future in the two countries are illustrated.