



## Freight distribution with electric vehicles: A case study in Sicily. Delivery van development



Giuseppe Napoli<sup>a,\*</sup>, Antonio Polimeni<sup>b</sup>, Salvatore Micari<sup>a</sup>, Giorgio Dispenza<sup>a</sup>,  
Vincenzo Antonucci<sup>a</sup>, Laura Andaloro<sup>a</sup>

<sup>a</sup> Institute for Advanced Energy Technologies “Nicola Giordano”, National Research Council of Italy, Salita S. Lucia sopra Contesse 5, 98126 Messina, Italy

<sup>b</sup> Department of Enterprise Engineering, “Tor Vergata”, University of Rome, Viale del Politecnico 1, 00133 Rome, Italy

### ARTICLE INFO

#### Keywords:

Sustainable logistics  
Electric vehicles  
Delivery Van  
Freight distribution  
LCV market

### ABSTRACT

A change in the logistics sector in terms of environmental sustainability is necessary to support the achievement of the social challenges associated with freight transport. Unfortunately, the policy responses to solving congestion and emissions issues are mainly dedicated to the movement of people. The most valued opportunities to reduce the negative effects of freight delivery (the goal of EU policy is CO<sub>2</sub> free urban logistics by 2030) regards both the use of electric vehicles to perform the distribution and the introduction of distribution centres that encourage the use of light commercial vehicles. However, the combination of zero emission vehicles in logistic and transportation activities requires some additional challenges from the organizational and operational point of view. In order to avoid the delocalization of polluting emissions it is necessary that the production of electricity related to the new needs comes from renewable sources preferably distributed throughout the territory.

This paper explores the integration of electric vehicles in logistics operations executed through light commercial vehicles, taking into consideration, during the design phase of a new concept delivery van, the technical connections with the production systems and its possible applications also in areas other than urban. The results of the case study presented encourage the development of a type of vehicle with features not yet covered by the market and which are of particular relevance for sustainable logistics applied to small towns or small islands, which are widespread in Italy.

### 1. Introduction

In parallel with the strong increase in the e-commerce industry throughout Europe the demand for a more advanced distribution network is increasing. Last mile delivery companies are investing in technology to make their fleets more efficient and the main delivery companies are looking carefully at the market for electric light commercial vehicles in order to meet the increasingly stringent limits on polluting emissions. In the EU, road transport accounted for 71.7% of CO<sub>2</sub> emissions in the transport sector [1]. In the city context, urbanization processes generate a constant increase in both people and volumes of freight, producing inevitable negative impacts on the environment and on liveability of the cities themselves. Several cities already implement measures for supporting the use of alternative fuelled vehicles, with low or zero emissions that represent a good starting point [2–6]. This transition is driven by the environmental sustainability, economy, government policies, inherent automotive industry dynamics and consumer

preferences [7]. The European Commission has recently adopted several political initiatives aimed at helping the EU transport sector in order to make it more sustainable and innovative [8]. Within them, an important role is assumed by those destined for freight transport whose relevance in the development policies of the mobility sector is undeniable, above all because most freight travel is by road (in the EU there are about three quarters of the total). Freight transport has numerous external costs (concerning mainly congestion and accidents) that can be quantified using an appropriate approach but its influence on the environment is certainly among the most relevant [9]. The goal for the central areas is to achieve a full integration of the flows of freight in the operations and activities of the cities, allowing citizens to access the freight they need by supporting sustainable development. In the long-distance context, the desired results is the implementation of intermodal transport services in a synchronized, intelligent and uninterrupted network through the support of corridors and hubs. Moreover, a coherent system that links both areas creating a truly integrated and sustainable

\* Corresponding author.

E-mail addresses: [giuseppe.napoli@itae.cnr.it](mailto:giuseppe.napoli@itae.cnr.it) (G. Napoli), [antonio.polimeni@uniroma2.it](mailto:antonio.polimeni@uniroma2.it) (A. Polimeni), [salvatore.micari@itae.cnr.it](mailto:salvatore.micari@itae.cnr.it) (S. Micari), [giorgio.dispenza@itae.cnr.it](mailto:giorgio.dispenza@itae.cnr.it) (G. Dispenza), [antonucci@itae.cnr.it](mailto:antonucci@itae.cnr.it) (V. Antonucci), [andaloro@itae.cnr.it](mailto:andaloro@itae.cnr.it) (L. Andaloro).

<https://doi.org/10.1016/j.treng.2021.100048>

Received 22 September 2020; Received in revised form 12 January 2021; Accepted 13 January 2021

2666-691X/© 2021 The Author(s). Published by Elsevier Ltd. This is an open access article under the CC BY license (<http://creativecommons.org/licenses/by/4.0/>)

freight transport system is desirable. There is a deep correlation between freight traffic and economic development. In [10] the authors show that in the first phase of development there is a strong push-pull interaction between economy and freight transport.

In recent years, however, there are emerging factors of divergence between urban and suburban logistics that are leading to the development of a city logistics distribution channel with adapted or new vehicles and operations, and a suburban distribution channel, with standard operation procedures with the consequence of reserving new technologies mainly to urban applications.

Through the literature review, it has also been noted that, while emerging the need for an overall assessment of the logistics system, the freight distribution with electric vehicles is generally evaluated in terms of a single perspective, not commonly from the point of view of the general panorama. Often it is considered only a perspective despite the fact that multiple parties are closely involved in the process of distributing goods and are heavily influenced by the effects [11]. There are multiple alternatives for urban logistic stakeholders to employ electric commercial vehicles for achieving sustainable urban freight transport. Pelletier et al. in their survey document, underline, however, that the integration of electric vehicles in freight transport increasingly depends on a series of factors linked to costs, technology, infrastructures, sources of electricity and financial incentives [12].

Wang and Thoben observed that few models have estimated the economic, environmental, and social performance of these alternatives [13]. Accordingly, they propose a concept to fill this gap with multi-criteria decision making. The analysis of the results achieved suggests however that further actions relating to infrastructures and management are also required in order to reduce the impacts on the environment [14–16]. The scenario proposed in this work defines a systemic approach taking into account three aspects: vehicles, infrastructures and operational dimension (the last two will be described in another article by the same authors).

Regarding the technical specifications of the vehicles delegated to deliver the freight, some extremely important factors emerge to support the development of sustainable logistics. The load capacity understood both from the point of view of the transportable weight and of the available surface, seems to be a determining factor for planning deliveries optimizing the number of journeys. However, in most cases, commercial vehicles with low environmental impact still have an approach based on the adaptation of solutions designed to host conventional propulsion systems.

The current offer of electric vehicles is also reduced, as is the ability to perform fast recharges, an important element in calculating the number of vehicles required for a fleet [17]. The importance of the charging process is also underlined by Margaritis et al. [18]. In their work challenges and recommendations are reported by authors with respect to Electric Vehicles (EVs) used in urban freight transport. The first aspect concerns the use of new materials for the chassis. Without compromising safety and stability, these can reduce the weight of the vehicle. Furthermore, the production of modular concepts of EVs on a cab chassis design for an urban vehicle is a current requirement of the sector in order to reduce the production costs and to make more attractive the EVs to fleet operators. The EV charging process is an important issue as it affects its use. Furthermore, for authors, the ability to charge more or less quickly, as mentioned, also affects its use, in terms of both availability and flexibility.

The article aims to analyze the possible trends related to technological change taking place in the field of sustainable logistics. The work attempts to direct the possible choices in the process of spreading the electric Light Commercial Vehicles (LCV) by highlighting, through a case study, the technical motivations behind the choices in the development of a prototype developed for the peculiarities of the Italian territory. The research activity therefore finds its place and its coherence in an overall scenario (vehicle, infrastructure, operational case study). It is for this reason that in [41] a description of the infras-

tructures developed to recharge the vehicle (in order to guarantee a really zero-emission on the territory) and a vehicle routing problem with time windows, has been proposed and formulated by the same authors.

The activities presented in the paper as a case study represents a sub-task of the iNEXT Project (Innovation for green Energy and eXchange in Transportation) that, along with other sustainable actions, propose the use of a new concept Electric Delivery Van to distribute the freight in different geographical contexts considering the energy production from renewable sources to feed the vehicle. From a preliminary analysis of the Italian territory emerges that, from the point of view of market opportunities, transport needs in small villages could be as interesting as the models applied to urban areas.

Based on these considerations, a new concept Electric Delivery Van (EDV) is proposed considering the key elements in order to make sustainable logistics possible not only in the last mile applications. Section 2 describes the global trends related to LCV. In Section 3, the Case study is introduced through an analysis on the Italian market and the territory taken as a reference to identify vehicle use missions. In Section 3 the vehicle, design and development phases are represented both from mechanical and technological point of view. Section 4 shows the results of the road test. Finally, the main points of the paper are summarized in conclusions.

## 2. LCV scenario

In December 2019, registrations of commercial vehicles increased by 5.7% across the EU. Vans drove demand, which accounted for over 86% of all registrations. Overall in 2019, the European Union's demand grew by + 2.5%, marking the seventh consecutive year of growth [19]. With the prospects linked to electrification and autonomous driving, the LCV market, driven above all by the new needs of e-commerce and home-delivery, is experiencing a new phase. Innovations in last mile delivery are set to highlight new applications for the use of light commercial vehicles. The partnerships between manufacturers and logistics and technology companies will open up important new growth opportunities especially for vehicles under 3.5 tonnes. Electric LCVs will clearly benefit from the scale volume achieved by electric cars. There are, however, some impediments to their widespread diffusion, mainly related to the costs and availability of the charging infrastructure and to those of the battery pack. Despite these obstacles, the EDV market forecasts for the coming years are very encouraging. Reducing battery prices and advances in autonomous driving technology will encourage the development of the sector, which will increasingly focus on the creation of zero-emission alternatives.

Major OEMs are expected to combine electrification with efforts to lighten vehicle weight. By reducing the weight of the vehicles, a significant reduction in CO<sub>2</sub> emissions can be achieved [20]. The use of advanced materials, electric propulsion and smaller size engines should help OEMs achieve their 2025 emission reduction targets which provide for a 15% reduction compared to 2021 [21].

Innovations in last mile delivery and stringent rules for access to urban centers are factors that are helping to promote the adoption of electric LCV and related solutions. A global market opportunity of 1.09 million units is expected by 2025 for electric LCVs [22]. Although some OEMs create new paradigms by creating innovative vehicles, many manufacturers still use a traditional approach by transforming existing platforms and dedicating themselves to updating only the levels of customization required by fleet managers based on the emergence of new service-based models. In parallel, fleet managers require a high level of customization, both in terms of design and functionality (configuration of the battery pack in relation to the mission of use, length, height, front or rear wheel drive, etc.). 100 new EDVs are expected to be launched worldwide by 2025. For this reason, the main players are seriously considering electrification and developing internal skills or collabora-

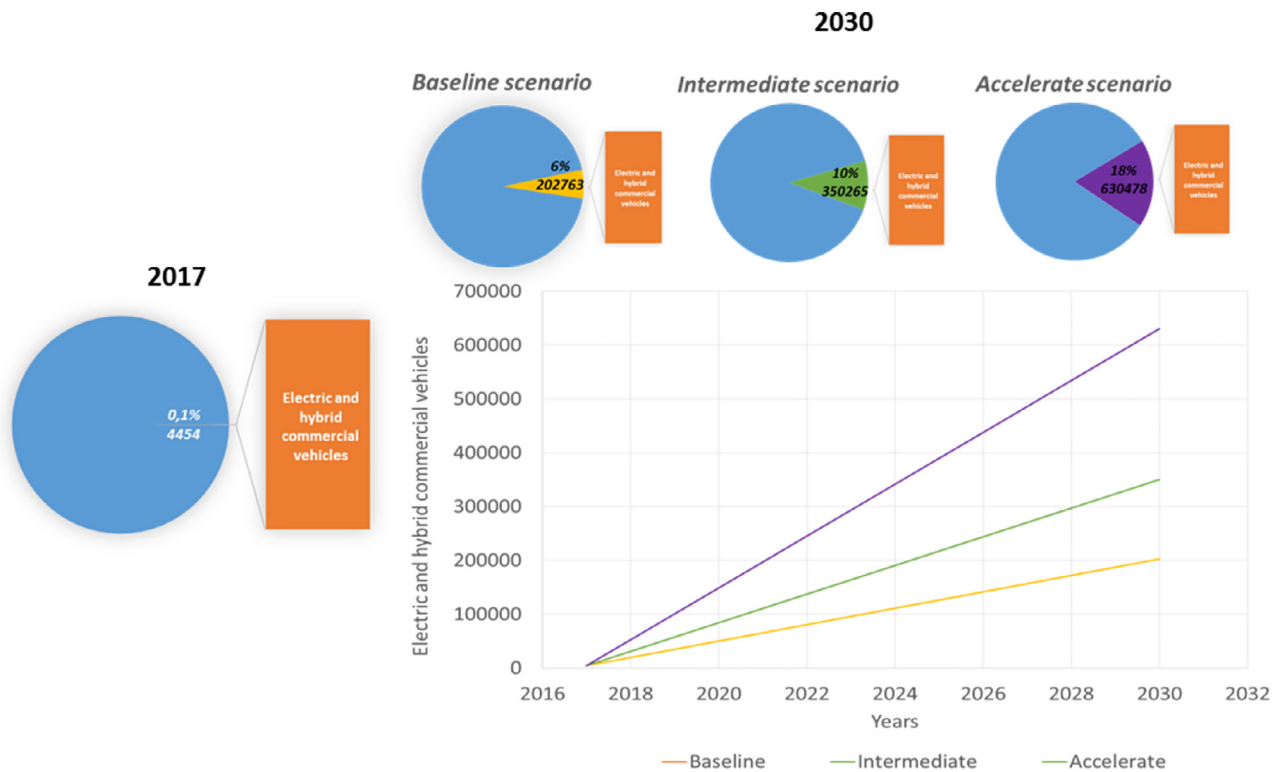

Fig. 1. Evolutive scenarios of the spread of electric and hybrid commercial vehicles. The graph shows a linear interpolation .

tions with battery manufacturers. Development costs still remain high and the technical requirements of the vehicles, as a precaution, are for now mainly based on urban applications for vehicles under 3.5 tonnes. The demand for light commercial transport will continue to grow even in suburban areas as new purchasing trends and the consequent need for more frequent deliveries will affect all areas, not just urbanized ones. Fleet managers can generally predict operating costs unlike private users. This aspect, together with a high average annual distance will facilitate the transition to the use of electric LCVs in larger economies of scale. In commercial fleets, moreover, it is possible to program the route and the relative intervals for vehicle charging which can typically be performed in one of the depots [23]. In [24] the authors propose EDVs as an adequate and efficient alternative to traditional intra-city freight transport showing that their use allows to reduce energy consumption in suburban areas with respect conventional distribution. The study reported in [25] aimed to analyze the state of the art of e-Mobility in Italy and to identify the most relevant industrial and modernization opportunities. The work analyzed the state of the art of e-Mobility in Italy and identified the most relevant industrial and modernization opportunities. Considering only the electric vehicle market and the sales that can be generated in each phase of the chain connected to it (motor vehicles, electric recharging infrastructures, ICT services, recycling and second life), it has been estimated that, in the various hypothetical development scenarios, it could activate a cumulative revenue of between 68 and 303 billion euros by 2030. As far as electric mobility is concerned, Italy today is in a backward situation compared to international competitors.

With the aim of building a framework within which to estimate the achievable turnover along the extended industrial value of e-Mobility chain in Italy by 2030, three alternative scenarios (baseline, intermediate and accelerated) were proposed in [26] for electricity penetration by 2030 in Italy. Table 1 and Fig. 1 show the growth potential relating to EDVs compared to 2017 (0,1% of stock). The analysis of the extended e-Mobility value chain and the development scenarios represent great industrial and economic potential for Italy.

Table 1

Electrical LCVs - Growth prospects for 2030 in Italy compared to 2017.

SCENARIO	GROWTH PROSPECTS TO 2030
Baseline	+4552% (6% of stock)
Intermediate	+7864% (10% of stock)
Accelerated	+14,155% (18% of stock)

### 3. Case study

About 70% of Italian municipalities (roughly 5.700) have less than 5.000 inhabitants and just over 90% (roughly 7.200) have less than 15.000. On these territorial realities, deeply different from the large metropolitan areas, can be started a social-economic development through the use of new technologies, developing *ad hoc* models and services . In 2019, a total of 312,000 LCV were produced in Italy. An important production for employment and exports. There were approximately 188,000 registrations in 2019 (+3,5%). In terms of new volumes, Italy is 5th in the EU market, behind France (478,000), the United Kingdom (366,000), Germany (approximately 305,000) and Spain (215,000). Market trends and exports have helped to keep domestic production of LCV high, a sector that generates a positive trade balance [27].

In the following, technical specifications of the LCVs within the N1 category (vehicles designed and constructed for the carriage of freight and having a maximum mass not exceeding 3,5 tonnes) and currently on the Italian market are analyzed. After a focus on the electrical ones, an evaluation of the testing area selected in the iNEXT Project is reported. The choice fell on a vast area comprising the municipality of Capo d’Orlando (Sicily, Italy) which combines the needs of a last mile distribution in an urban area with the needs linked to distribution in small villages through suburban roads. The overall objective is to identify those that are considered the critical elements of the current offer in view of developing a vehicle that can perform the dual function.

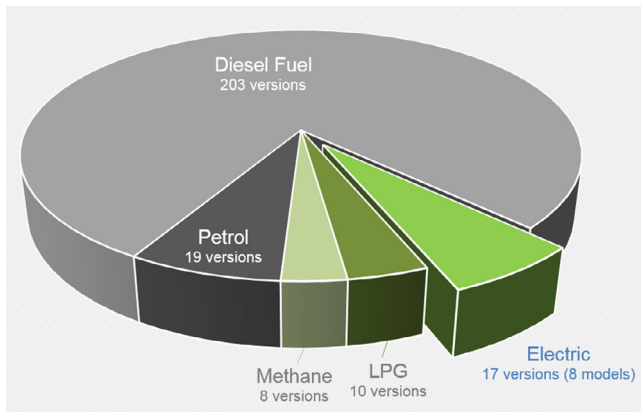

Fig. 2. LCV offer in Italy. Division by fuel.

### 3.1. LCV Italian market

The Italian market offers 71 LCV models with 256 different versions extremely diversified with regards to vehicle (van, box van, mini-van, pick-up) and loading area dimensions, chassis (unibody or body-on-frame) and fuel (Diesel Fuel, Gasoline, Liquefied Petroleum Gas, Methane or Electric). Fig. 2 shows the model division by fuel while Table 2 reports the main features relating to the EV taken as reference for the preliminary analysis in 2018. Except for Alkè vehicles (Lead acid or Gel) and Piaggio Porter (Lead Gel), the batteries are based on Lithium chemistry. However, it should be noted that the maximum range value reported by manufacturers refers to the NEDC driving cycle or to road tests with the vehicle in optimal use configuration [A1-A10].

Compared to the chassis it is noted that only half have opted for the so-called Body on frame. The lengths vary between 340 and 622.5 cm and even with respect to the loading surface and payload the panorama is quite varied with areas under 2 m<sup>2</sup> for smaller vehicles and rarely more than 5 m<sup>2</sup> and payloads ranging from 450 to 1078. The aspect related to the charging systems is quite critical as only three vehicles offer a fast charge (Nissan e-NV200, Peugeot Partner Full Electric, Renault Kangoo Z.E.) and only for three of the remaining (Alkè ATX340EX/ED and Nissan e-NV200) is the possibility of using an external charger available as an option. With a length of more than 500 cm, the Renault Master Z.E is not very suitable for moving easily in city centers and small villages. On the other hand, the high loading area and the high payload can contribute to delivering freight with a smaller number of trips and in this sense the Piaggio Porter Electric, the Renault New Kangoo Van ZE, the Peugeot Partner Electric, the Citroen E-Berlingo and the Alkè ATX340E offer a loading surface that, at best, is only a little over 2 m<sup>2</sup>. Finally, only for one vehicle there is the possibility of being able to carry two Europallets (120 cm × 80 cm × 14.4 cm) at the same time (Master Z.E. PANEL VAN).

### 3.2. Territorial context

In the territorial area that embraces the central Tyrrhenian coast of the province of Messina, Capo d'Orlando represents an important pole of attraction. The city has about 13,000 permanent inhabitants, which triples in the summer period and who have a high demand for mobility with respect to the neighboring inhabited centers (Brolo, Patti, S.Agata Militello), the entire Nebrodi area (more than 40 municipalities with a total population of over 150,000 inhabitants which represent the largest protected natural area in Sicily), and with respect to the Provinces of Messina, Catania and Palermo, which is respectively 90 km, 120 km and 145 km (Fig. 3). The idea is to envisage the presence of an Urban Distribution Center (UDC) for freight adjacent to the urban area of Capo d'Orlando, near the motorway junctions. This hub will be useful both for vehicles that will have to provide urban distribution within the last

mile (not more than 10 km), and to start distribution in the Nebrodi district in the small villages reachable through roads narrow that require high maneuverability of the vehicle. In this case the distance to travel is included, in the most frequent cases, between 29 and 62 km with a slope that can be greater than 10% [4].

## 4. A new concept electric delivery van

A new concept vehicle has been designed and developed specifically for the project taking into account the considerations the technical specifications relating to the current electric LCV offer, reported in the previous Section. In particular chassis, load capacity, dimensions and charging process have been analyzed in order to evaluate possible elements for improvement with respect to the market proposal. Some main constraints have therefore been fixed considering the dual field of use of the vehicle: last mile for urban applications and small village for suburban applications (Table 3). Since the vehicle will have to guarantee a high degree of modularity allowing different possibilities both for the transport of freight and for people a *Body on frame* chassis has been considered the most suitable choice. The maximum *Length* was determined taking into consideration the indications deriving from the analysis of the geometric characteristics of the minor and rural extra-urban roads in Italy [28]. In particular, the narrowest streets provide, in the worst case, a carriageway width of 2.5 m with a bend radius of 5 m. A greater overall length would make it impossible to transit in most of the streets of the small villages. The minimum value of the *Payload* has been fixed taking into consideration both the characteristics of the vehicles on the market and the need for a hypothetical distribution in the study area. To perform a preliminary simulation of the freight distribution in a typical day, the retailers in the study area are identified and distinguished by type of freight purchased. The retailers have been divided into groups and a set of delivery point have been located. Following the method reported in [29] a Vehicle Routing Problem (VRP) has been performed. From the analysis carried out for urban application, taking into account the volumetric weight [30], the route with the heaviest load provides for a transport of less than 200 kg. Considering an average positioning compared to the current offer of EDVs and taking into account the possible needs deriving from suburban applications, the constraint as a precaution was set at 600 kg. With regard to the *Load Area*, a value has been set that would favor loading and unloading activities as much as possible, minimizing time and allowing easy positioning of *two Europallets*. This last condition, not satisfied by many vehicles on the market, has been further added as a constraint in order to guarantee the highest degree of versatility. Fig. 4 shows Payload and Load Area coefficients of the commercial proposals. The best performing version was selected for each model.

To ensure the possibility of making suburban roads with high slopes and uneven terrain, the constraint of independent *Four-wheel drive* has been fixed. About the Energy Storage System (ESS), Lithium ion polymer batteries have been chosen [31,32]. The main characteristics of this *Chemistry* are the high energy density (up to one hundred-fifty Wh/kg), the high number of life cycles (even though in specific conditions: 1500 up to 80% of DOD) and the high typical discharge ratio: (up to 2,5 C continuous current and 5 C maximum value of discharge current). The reduction of cost and time related to the design, prototyping and testing of a Li-ion battery pack, which is used in lightweight commercial full electric vehicles, are reported in Cicconi, P. et al. [33]. The need to minimize vehicle parking times for *Electric Charging*, with a view to an overall reduction in the number of vehicles in a potential fleet, has led to the belief that a fast charging system with power no less to 22 kW is a fundamental requirement [34]. With regard to the *Range*, the constraint was determined on the basis of the considerations reported in Section 3.2. Taking into account the presence of four-wheel drive and the nominal consumption of the main vehicles on the market, a consumption of less than 160 Wh/Km has been considered sufficient to guarantee the achievement of project targets in the geographical area

**Table 2**  
Electric LCV sold in the Italian market (category N1).

Manufacturer	ALKE'		CITROEN	NISSAN	PEUGEOT	PIAGGIO	RENAULT	
Model	ATX340EX	ATX340ED	Berlingo Van	e-NV200	Partner Full	Porter	Kangoo Z.E.	Master Z.E.
Classification	Loading Bed	Loading Bed	Full Electric Mini Van	Van	Electric Mini Van	ElectricPower Van or Loading Bed	Van	PANEL VAN Van
Car seats	2	4	2 <sup>(9)</sup> 3 <sup>(10)</sup> 3 <sup>(11)</sup>	2	2	2	2	2
Chassis	Body on frame	Body on frame	Unit body	Unit body	Unit body	Body on frame	Unit Body	Body on frame
Length (cm)	353 <sup>(1)</sup>	429 <sup>(1)</sup>	438 <sup>(9)</sup> 438 <sup>(10)</sup> 462.8 <sup>(11)</sup>	456	438 <sup>(14)</sup> 462.8 <sup>(15)</sup>	355.5 <sup>(18)</sup> 342 <sup>(19)</sup> 377.5 <sup>(20)</sup> 356.5 <sup>(21)</sup> 340 <sup>(22)(23)</sup>	428.2 <sup>(25)</sup> 466.6 <sup>(26)(27)(28)</sup>	507.5 <sup>(33)(34)</sup> 557.5 <sup>(35)</sup> 622.5 <sup>(36)</sup>
Width (cm)	157 <sup>(2)</sup>	157 <sup>(2)</sup>	181	201.1 <sup>(12)</sup>	181	139.5 <sup>(18)</sup> 146 <sup>(20)</sup> 170.5 <sup>(18)(19)(20)</sup> 180 <sup>(21)</sup> 187 <sup>(22)(23)</sup>	213.8 <sup>(29)</sup>	247 <sup>(37)</sup>
Height (cm)	194 <sup>(3)</sup>	194 <sup>(3)</sup>	182.2	184.5	183.4 <sup>(14)</sup> 183.2 <sup>(15)</sup>	170.5 <sup>(18)(19)(20)</sup> 180 <sup>(21)</sup> 187 <sup>(22)(23)</sup>	184.4 <sup>(25)(30)</sup> 183.6 <sup>(26)(30)</sup> 182.6 <sup>(27)(28)(30)</sup>	230.7 <sup>(33)</sup> 250 <sup>(34)</sup> 249.9 <sup>(35)</sup> 248.8 <sup>(36)</sup>
Load Area L x W (cm) - m <sup>2</sup>	180 × 124- 2,23 <sup>(4)</sup>	180 × 124- 2,23 <sup>(4)</sup>	180 × 162 - 2,91 <sup>(9)</sup> 300 × 162 - 4,86 <sup>(10)</sup> 325 × 162 - 5,26 <sup>(11)</sup>	204 × 150 - 3,06	180 × 162 - 2,91 <sup>(14)(**)</sup> 205 × 150 - 3,07 <sup>(15)(***)</sup>	- <sup>(18)</sup> 133 × 198 - 2,63 <sup>(19)</sup> 140 × 232.5 - 3,25 <sup>(20)</sup> 140 × 193 - 2,7 <sup>(21)</sup> 121 × 191 - 2,31 <sup>(22)</sup> 121 × 92 - 1,11 <sup>(23)</sup>	147.6 × 121.9 - 1,8 <sup>(25)</sup> 186 × 121.9 - 2,26 <sup>(26)</sup> 100.8 × 121.9 - 1,23 <sup>(27)</sup> 136.1 × 121.9 - 1,66 <sup>(28)</sup>	258.3 × 176.5 - 4,56 <sup>(33)</sup> 258.3 × 176.5 - 4,56 <sup>(34)</sup> 308.3 × 176.5 - 5,44 <sup>(35)</sup> 373.3 × 176.5 - 6,59 <sup>(36)</sup>
Curb vehicle weight (kg)	1305 <sup>(5)</sup>	1425 <sup>(5)</sup>	1605 <sup>(9)</sup> 1664 <sup>(10)</sup> 1703 <sup>(11)</sup>	1555–1687 <sup>(13)</sup>	1664 <sup>(14)(16)</sup> 1703 <sup>(15)(16)</sup>	- <sup>(18)</sup> 1260 <sup>(19)(24)</sup> 1280 <sup>(20)(24)</sup> 1350 <sup>(21)(24)</sup> 1330 <sup>(22)(24)</sup> 1370 <sup>(23)(24)</sup>	1505 <sup>(25)</sup> 1585 <sup>(26)</sup> 1630 <sup>(27)</sup> 1631 <sup>(28)</sup>	2422 <sup>(33)</sup> 2450 <sup>(34)</sup> 2494 <sup>(35)</sup> 2575 <sup>(36)</sup>
Payload (kg)	1075 <sup>(6)</sup>	955 <sup>(6)</sup>	620 <sup>(9)</sup> 561 <sup>(10)</sup> 477 <sup>(11)</sup>	695	561 <sup>(14)</sup> 477 <sup>(15)</sup>	as allowed by the vehicle configuration <sup>(18)</sup> 540 <sup>(19)</sup> 520 <sup>(20)</sup> 450 <sup>(21)</sup> 470 <sup>(22)</sup> 430 <sup>(23)</sup>	625 <sup>(25)</sup> 605 <sup>(26)</sup> 640 <sup>(27)</sup> 639 <sup>(28)</sup>	1078 <sup>(33)</sup> 1050 <sup>(34)</sup> 1006 <sup>(35)</sup> 925 <sup>(36)</sup>
Motor Power (kW)	14	14	49	80	49	10,5	44	57
Battery Energy (kWh) [Chem- istry]	14.4 [Lead Acid] <sup>(*)</sup>	14.4 [Lead Acid] <sup>(*)</sup>	22,5 [Lithium ion]	24 [Lithium Ion]	22,5 [Lithium ion]	17 [Lead Gel]	33 [Lithium ion]	33 [Lithium ion]
Traction	13.2 [Gel] <sup>(*)</sup> rear wheel	13.2 [Gel] <sup>(*)</sup> rear wheel	front-wheel	front-wheel	front-wheel	-	front-wheel	front or rear wheel
Range (km)	90 <sup>(7)</sup>	85 <sup>(7)</sup>	170	163	170	110	217 <sup>(32)</sup>	120
Slow Charging Time	8 h @ 1.8kW <sup>(8)</sup> [Lead Acid]	8 h @ 1.8kW <sup>(8)</sup> [Lead Acid]	10 h @ 2.3 kW	10 h @ 2.4 kW with home plug	15 h @ 1.5 kW <sup>(17)</sup>	8 h @ 2kW	17 h @ 2.3 kW	6 h @ 7.4kW
	11 h @ 1.2kW <sup>(8)</sup> [Gel]	11 h @ 1.2kW <sup>(8)</sup> [Gel]	6 h @ 3.7kW	7h@3.7 kW type 1	8 h @ 2.81 kW <sup>(17)</sup>		12 h @3.3 kW	
				5.5h@4.6kW	7 h 30 min. @ 3 kW <sup>(17)</sup>		11h@3.7 kW	
Fast Charging Time	-	-		30 min. @ 50 kW CHAdEMO (up to 80%)	30 min. @50 kW CHAdEMO (up to 80%)	-	6h@22 kW 6h@43 kW	-
References	[A1]	[A2]; [A3]	[A4]	[A5]; [A6]	[A7]	[A8]	Plug and vehicle side: IEC 62,196 - Type 2 Mennekes Mode 3, or Mode 2 with EVSE cable limited to 10amps [A9]; [A10]; [A11]	

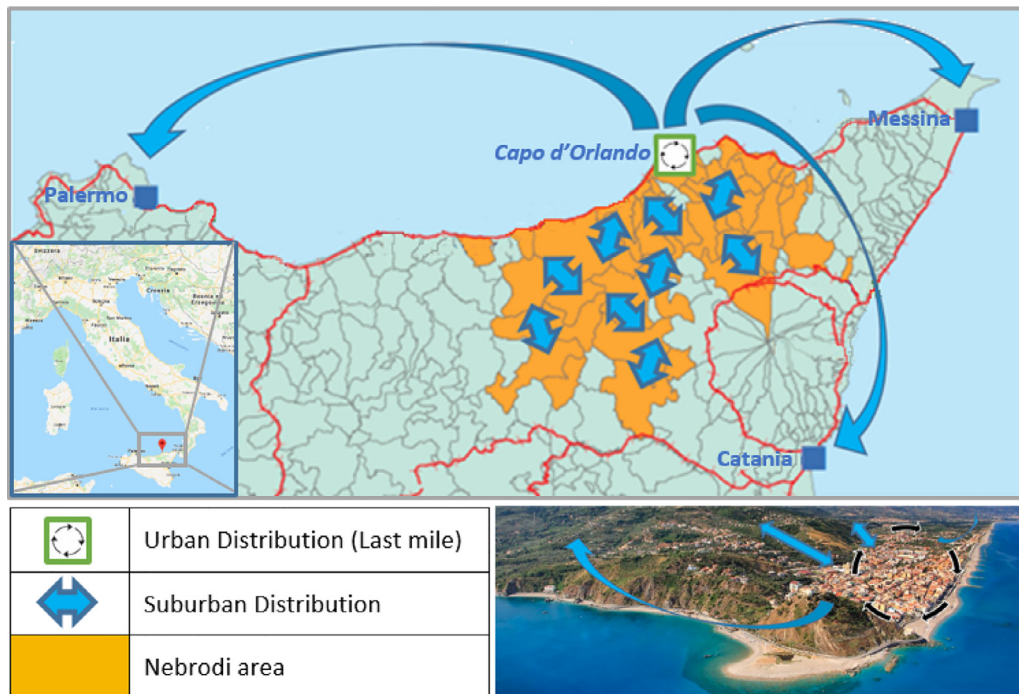

Fig. 3. Testing site. Conceptual scheme of urban and suburban distribution.

Table 3  
EDV. Main project constraints.

	Constraints	Reasons
Chassis	Body on frame	Modularity (different choices for the upper body)
Length	< 500 [cm]	Maneuverability
Payload	> 600 [kg]	Versatility
Load Area	> 5 [m <sup>2</sup> ]	Versatility
Load Area	Possibility of carrying two Europallets (120 × 80 cm)	Versatility
Traction	4-wheel drive	Versatility (for challenging suburban roads)
Battery Chemistry	Lithium	Efficiency, Performance, Fast charge qualification
Battery Capacity	28,8 ÷ 31,68 [kWh]	Performance
Electric Charging	≥ 22 kW (with recharge time 20÷80% Soc < 1 h)	Reduction of vehicle downtime (for optimization of the number of vehicles in the fleets)
Range (under WLTP test cycle)	≥ 150 km	Versatility

under study. For reference, based on manufacturer data, the range of vehicles on the market shown in Table 2 have a nominal consumption between 105 and 220 Wh/km. Bearing in mind that the battery availability is conventionally equal to 80% of the nominal, to guarantee the minimum range required with the nominal consumption, the battery pack capacity must be no less than 28.8 kWh. On the other hand, too high a capacity value would affect costs, weight and charging times. For this reason, an upper limit of + 10% of the minimum capacity has been also set, which determined for the Battery Capacity the range shown in Table 3.

The total power-to-weight ratio is a measure of the actual performance of any engine or power source. This parameter is important in using EDV because it determines acceleration and speed (e.g.: rough roads with high slope even at full load during suburban applications) and performance in frequent start and stop (e.g.: during urban cycles). The ratio between payload and total weight is instead a good compromise as regards the load capacity compared to the available surface.

In order to further analyze the performance of the EDVs, the following two additional parameters were therefore introduced:

$$P_1 = \text{Power to total weight ratio;}$$

$$P_2 = \text{Payload to total weight ratio defined as:}$$

$$P_1 = \frac{\text{Motor Power (W)}}{\text{Curb vehicle weight (kg)}}$$

$$P_2 = \frac{\text{Payload (kg)}}{\text{Gross vehicle weight (kg)}}$$

For the applications envisaged, the first parameter has been considered of priority interest.

With the aim of improving the characteristics compared to most of the vehicles on the market, the following further constraints were therefore established (Fig. 5):

$$P_1 > 50 \text{ W/kg;}$$

$$P_2 > 0,4$$

#### 4.1. Chassis and mechanical solutions

Based on the constraints described above a Body on frame chassis has been selected (Fig. 6 and Fig. 7).

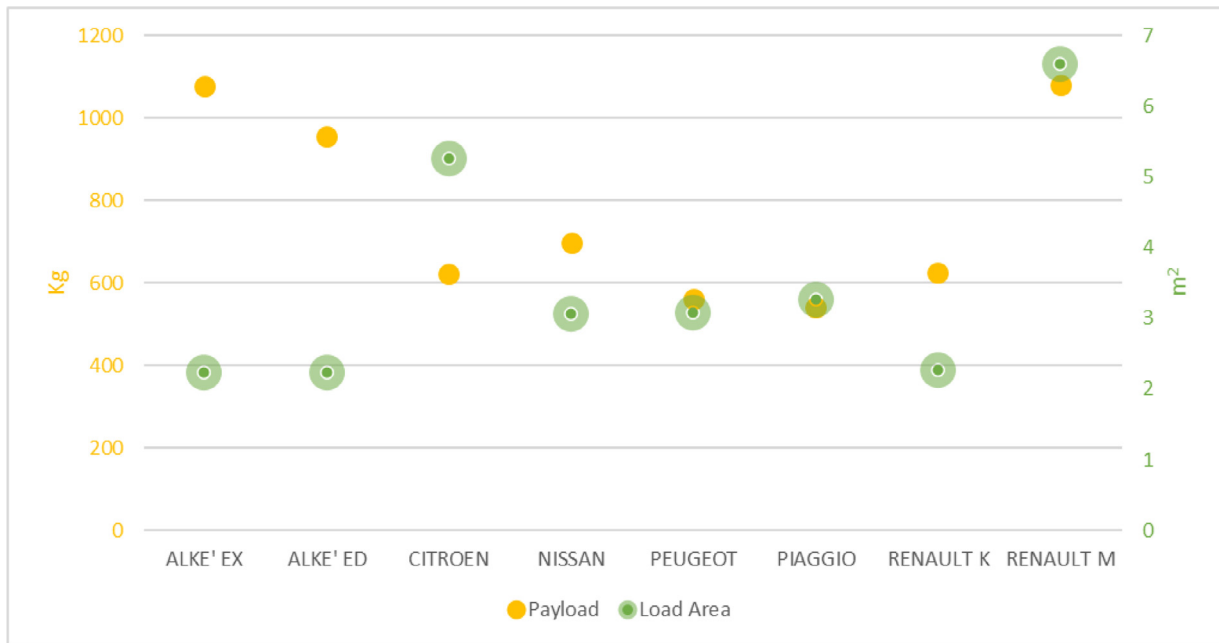

Fig. 4. Payload and load area. Positioning of the main Electric LCVs sold in the italian market (category N1).

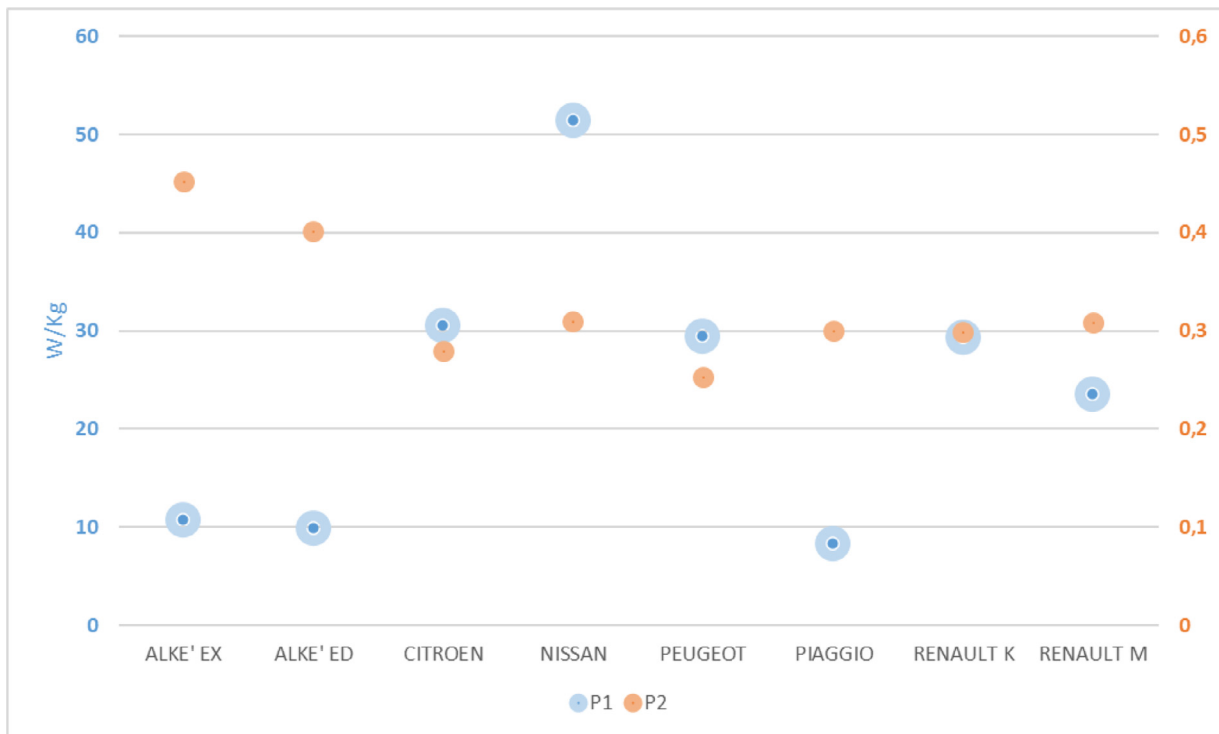

Fig. 5. P1 and P2. Positioning of the main Electric LCVs sold in the italian market (category N1).

In adopting a very traditional solution, the element of innovation consists of the construction of the aluminium main spar made by extrusion with an I-beam profile specifically designed for this application.

The use of aluminium extrusions and specific connected elements guarantees high torsional rigidity under heavy loads strain and high levels of impact protection, in particular for the battery pack, the driver and the passengers. After having subjected the frame chassis to some numerical verifications on the flexural and torsional stiffnesses, on the main vibrational modes and on the inertial load the frame was completed with the frame superstructure to support the front and rear shock absorbers

as well as the linkage setting for traction axles and the brakes (disk on both axes). Such structures are made of high-strength steel. MacPherson suspensions are used for the front, which is now practically standard on almost all newly designed LCV. The rear suspension is bi-link type and represents a top-of-the-range solution to ensure high grip even in rough conditions on uneven ground.

In order to simultaneously respect the constraints imposed on the length of the vehicle and on the loading surface, an element of particular importance has been given to the footprint of the vehicle, trying to minimize the surface occupied with respect to the loading area. Be-

Fig. 6. Body on frame structure.

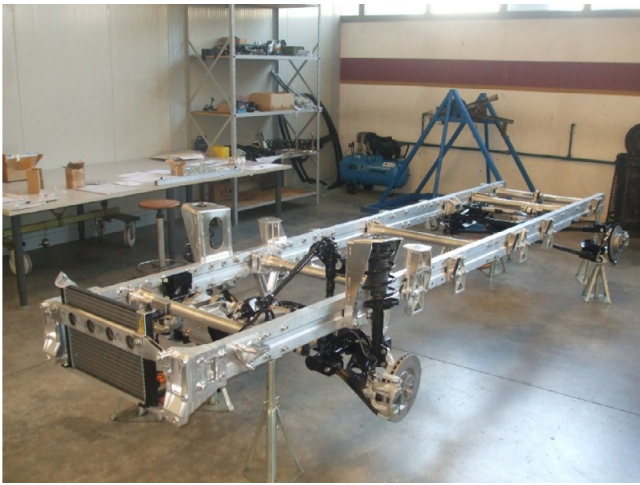
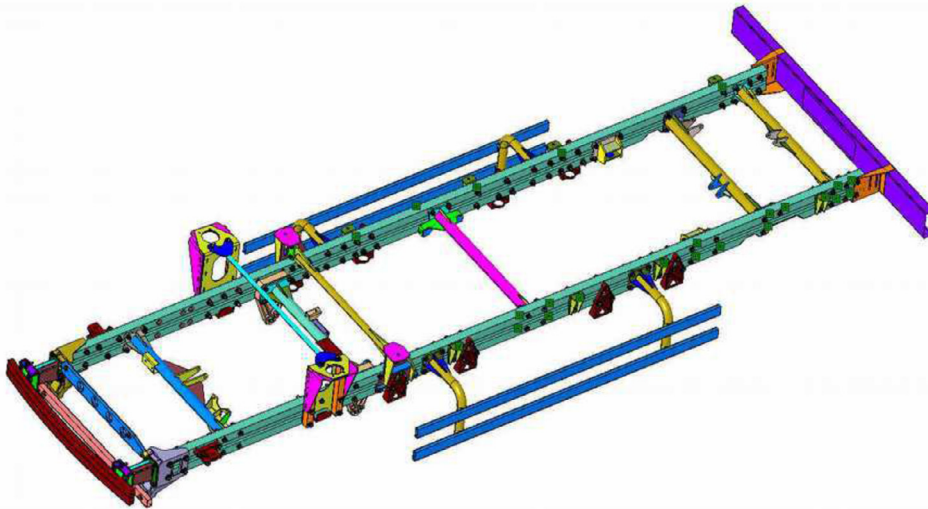

Fig. 7. Mechanized frame assembly.

cause the setting of the driver's cab with respect to the loading floor influences this relationship, a cab in an advanced position with driver placed above the front end axle has been designed maximizing the useful ratio between overall dimensions and loading surface.

As shown in Fig. 8 with the same wheelbase C (280 cm) and total length A (490 cm) this solution allowed to recover the length x (95,2 cm) with respect to the length of the loading area B (204,8 cm) compared to a conventional approach.

The servo-assisted steering box required the identification of a non-standard solution due to the advanced position of the driver's cab and driver.

The mechanization of the chassis has been then completed with the positioning of the elements of the propulsion system (electric axles, gear-motor, control and actuating electronics, battery packs) conveniently positioned between the traction axles and the longitudinal members in a barycentric and secured manner (Fig. 9 and Fig. 10). Figs. 11 and 12 show the structure of the cabin and the chassis with mechanical components.

One of the main characteristics of the chassis is the arrangement of the battery pack in a lower and protected position. The frame is completed with the substructures of high-strength steel to support the front and rear suspension as well as the traction axles and the brakes (disk on both axles).

The vehicle has a new concept for design and a large windscreen, with a high ratio between total glass surface and total area of the cabin, to allow high driving position and higher visibility than those of similar vehicles (Fig. 13). In the project the *Van version* was developed but, as said, the frame allows the installation of different upper bodies. Fig. 14 also shows a hypothetical *Box version*.

#### 4.2. Fast charge and energy storage solutions

Estimating as 160 Wh/km the (maximum) nominal foreseeable consumption of the vehicle, in order to reach its day delivery target the ESS has to be preliminary sized with a rated energy of about 30 kWh (24 kWh available).

After verifying the energy sizing through appropriate simulation models 20 Kokam cells of 40 Ah in series have been installed in modules of 74 Vdc. 5 modules have been connected in series to obtain a subpack of 370 Vdc (Fig. 15). The complete ESS is composed of 2 sub-pack in parallel.

Fig. 16 shows the behavior of the lithium ion polymer batteries in the discharge phase with different values of the C-Rate has through test performed at CNR ITAE during ESS development.

The system designed to recharge the batteries is based on the Brusa NLG664 commercial battery charger able to communicate via the CAN network with battery packs for the management of charging and the charging stations. Galvanic isolation ensures electrical safety, while flexible supply from single phase or three phase AC outlets of different power levels guarantee smooth and reliable operation. The power can reach 22 kW. In charge phase, the energy flow is started according to the set values requested by CAN, as soon as AC and DC voltage are applied. The charging current slope is limited by software. This prevents unexpected load changes on the AC supply. A charge from 20% to 80% can be performed in about 55 min. An AC power recharge interface has been implemented by a Type 2 connector as showed in Fig. 17 [35,36].

#### 4.3. Motor and control unit

With the aim of guaranteeing versatility with respect to the missions of use of the vehicle and ensuring its use also to tackle routes with uneven terrain and challenging slopes, two identical electric motors have been used, one for the front axle and the other for the rear axle. (Fig. 18). The electric engines, with nominal voltage of 350 Vdc, are Interior Permanent Magnets (IPM) type, guaranteeing high performances in term of power and efficiency. IPM engines use a higher number of magnets than the surface mounted PM motors but they have an extended speed



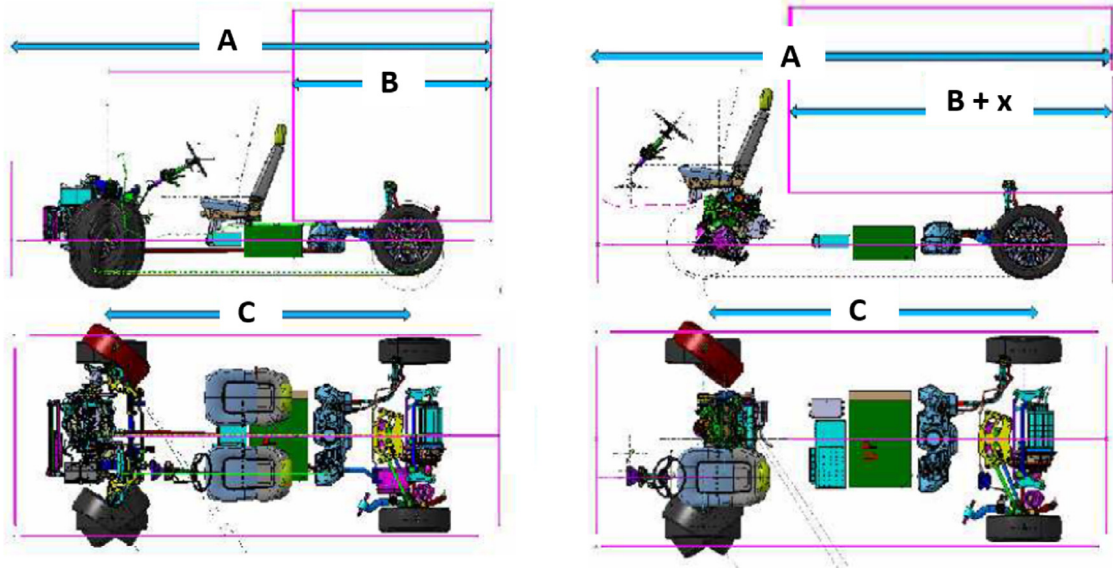

Fig. 8. Comparison of the cab position and load compartment length (with the same pitch  $C$ , and total length  $A$ ).

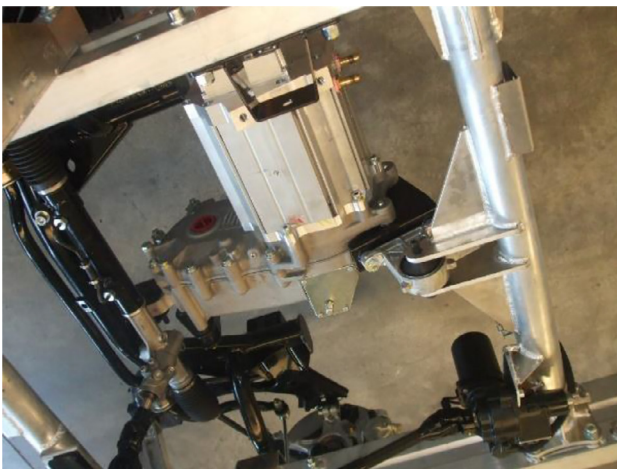

Fig. 9. Front and rear gearmotor assembly.

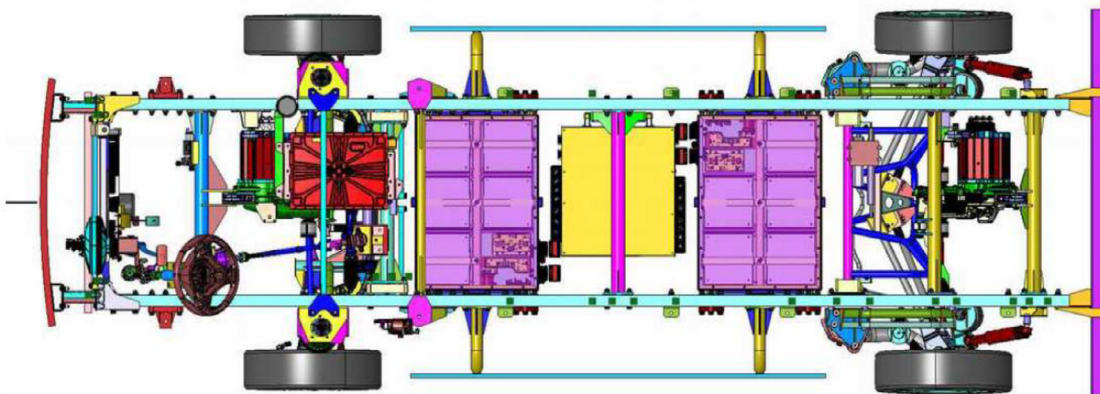

Fig. 10. Plan view of the mechanized frame.

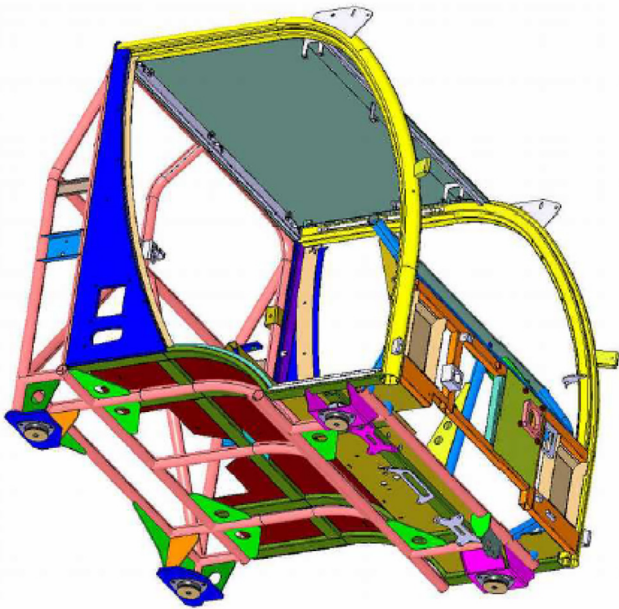

Fig. 11. Cabin framework with frame supports.

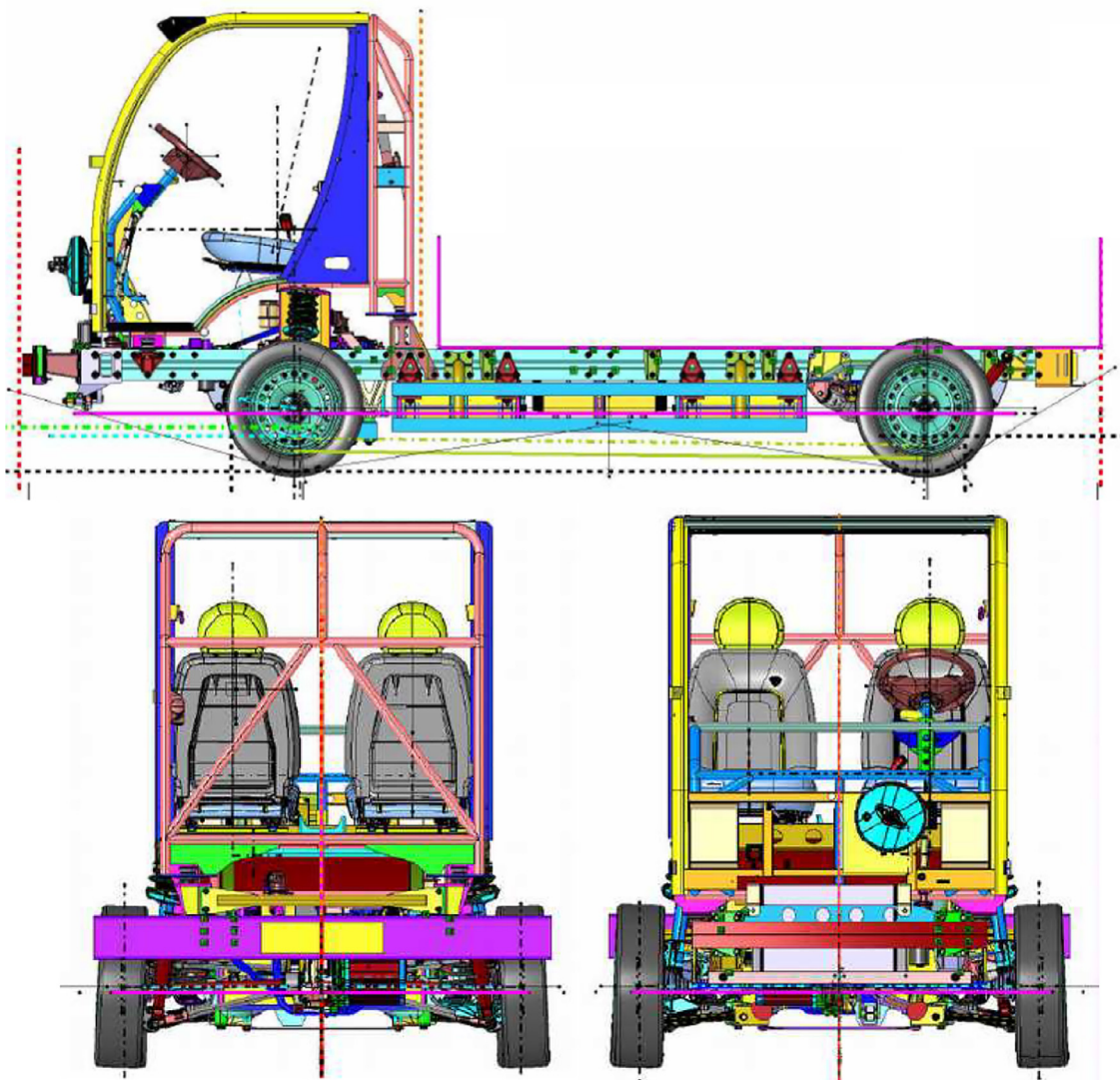

Fig. 12. Side front and back view of the mechanized chassis assembly with cab structure.

range with constant power operation over surface PM motors [37]. This option allowed have a wide field of engine speeds in which the output power can be kept constant, with a reduced inverter sizing, moreover in short circuit and overcharge conditions, interior magnets don't risk to be demagnetized; In particular, the proposal solution shows a four layers rotor, four flow barriers per pole. Each layer is partially filled with high energy density magnets (NdFeB). The stator has also a high number of slots (48 slots on a 2 pole pairs). The high number of layers of the rotor and an appropriate number of stator slots reduces iron losses. These characteristics make it particularly suitable for automotive applications because it cover the entire field of motor speed without the use of a mechanized gearbox.

The actuation and control unit is composed of a power section (Rapid Prototyping Power Part) based on Mitsubishi IPM Module and a control part (Rapid Prototyping Control Part) based on a Digital Signal Processor (floating point), on which has been implemented a highly structured code at different levels (Fig. 19).

The *Bottom layer* represents the hard real-time operating system (HRTOS); the *Middle layer* is the electric motor control code (Universal Direct FluxVector Control - UDFVC); the *Top layer* is instead a "user" part dedicated to traction management (Traction Manager). The control unit is equipped with two CAN ports for the vehicle network (SAE J1939 standard) and for the diagnostic network (UDS-OBD protocol). The lat-



Fig. 13. New concept for vehicle design.



Fig. 14. Van and Box versions.



Fig. 15. Battery subpack.

ter allows diagnostics by monitoring physical quantities (currents, temperatures, engine rpm) and system status (protection messages, alarm faults). The traction system software has a series of tools for the following functions: Acquisition of vehicle data and electrical variables of motors and control unit in real-time mode or data logging mode; On-

line modification of the system control parameters; Analysis of the time taken by the control unit.

The bench test phase was carried out using an electric traction test bench and involved the traction system included electric motor (IPM S3-M3), the differential reduction unit (TR-GT), the actuation and control

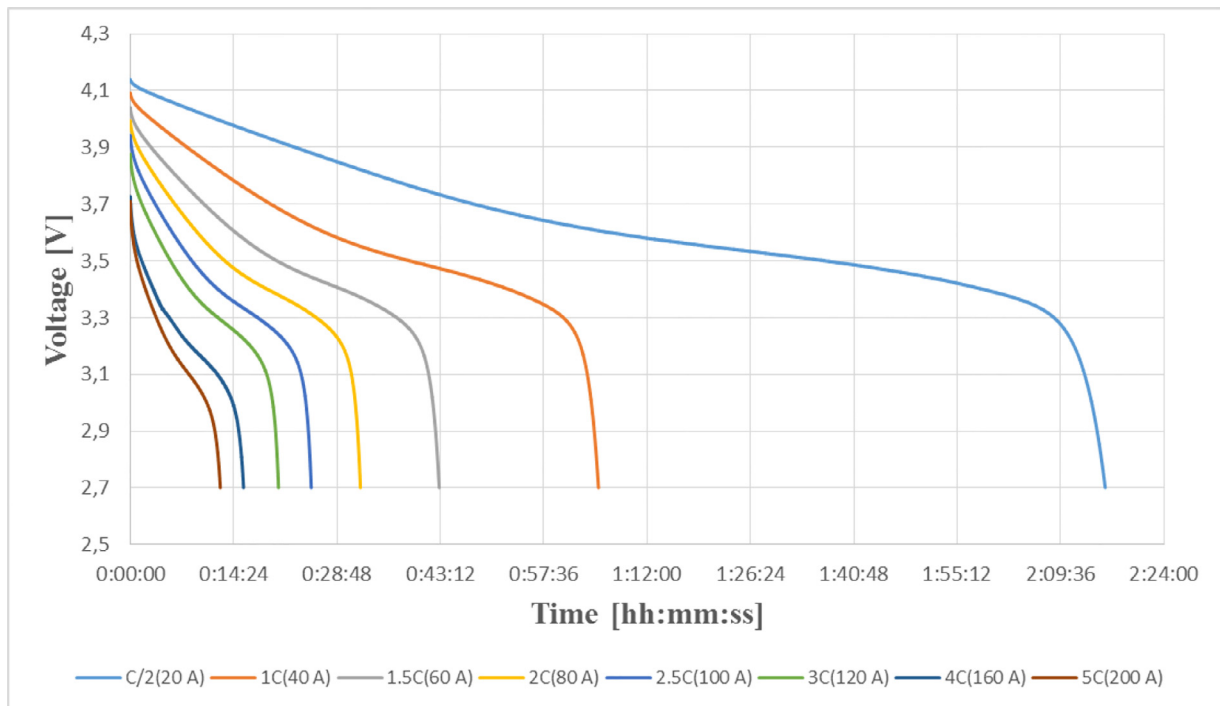

Fig. 16. Lithium ion polymer cells of 40 Ah under test.



Fig. 17. AC power recharge interface has been implemented by a Type 2 connector.

unit (AKU Box Dual flat 300A) and the ESS (Fig. 20). Test system consists of two sections:

- The *Motor room* in which electric motors and inverters have been tested and characterized. This section houses the electrical counter-machine that allows simulating loads and imposing speed profiles on the test axle. The torque exchanged between the electric axle and counter-machine was monitored by means of a torque meter. The acquisition system has allowed the synchronous acquisition of all the electrical quantities involved (phase currents, currents and DC bus voltages, etc...);

- The *Battery room* that allows to test and characterize the batteries by simulating temperatures in the range  $-40\text{ }^{\circ}\text{C}+60\text{ }^{\circ}\text{C}$ .

One of the tests included the measurement of the maximum and nominal output power of the traction motor (IPM S3-M3). The obtained torque and power values are compared in Fig. 21 [38] with those obtained on the test benches and with the expected theoretical data af-

ter preprocessing and outliers detection [39,40]. This comparison highlights the correct correlation between expected and actual performances over the entire operating range of the engine.

The block diagram of the vehicle power train is shown in Fig. 22.

## 5. Results and road test

Preliminary to the road tests, the functional testing of the traction system was carried out, also verifying that the performance, in terms of range, was consistent with those required by the specification. With regard to consumption data, the Table 4 shows the distance that can be traveled by the vehicle subjected to a WLTP cycle.

The results show a range of 195,7 km, much higher than that fixed by the design constraint (150 km). In order to verify and validate on field the technical design specifications of the vehicle some on-road tests have been also executed in the testing site described in Section 3 (Capo



Fig. 18. Electric motor.

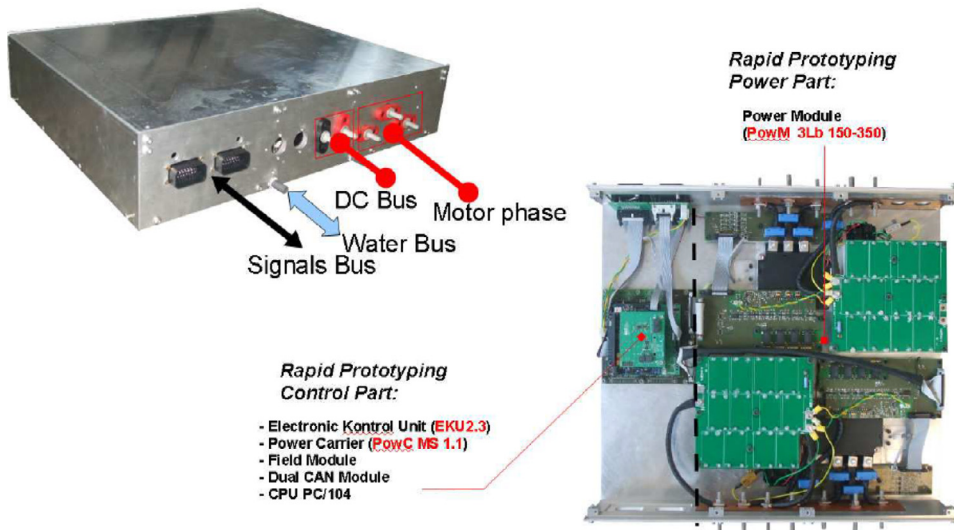

Fig. 19. Actuation and control unit (AKU Box Dual Flat 300 A).

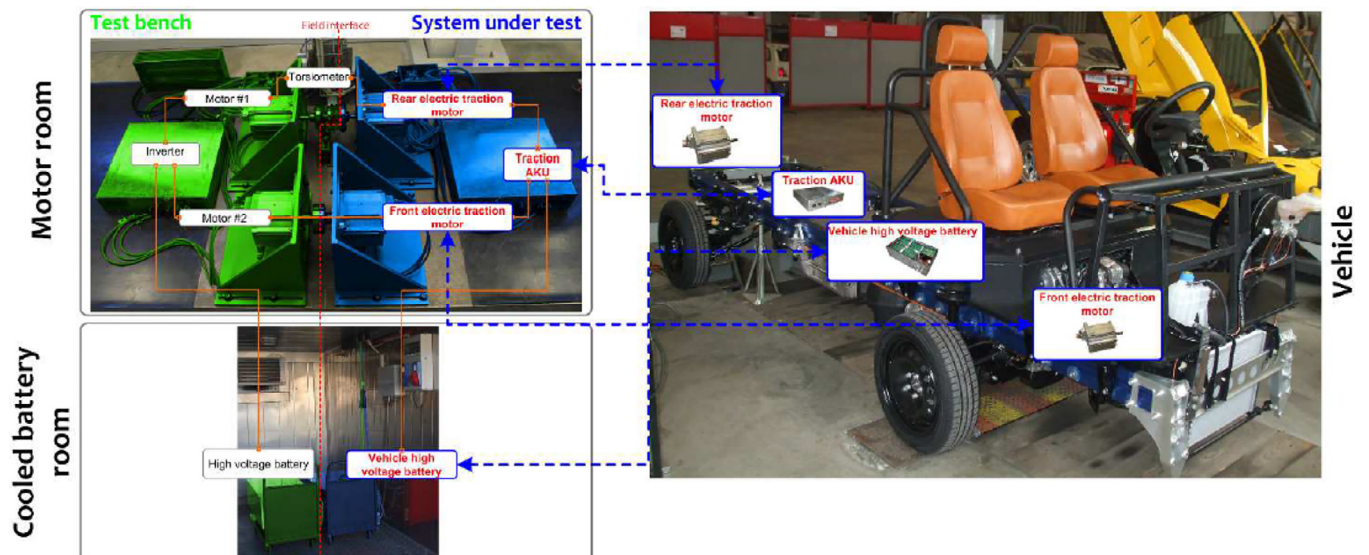

Fig. 20. Experimental test scheme.

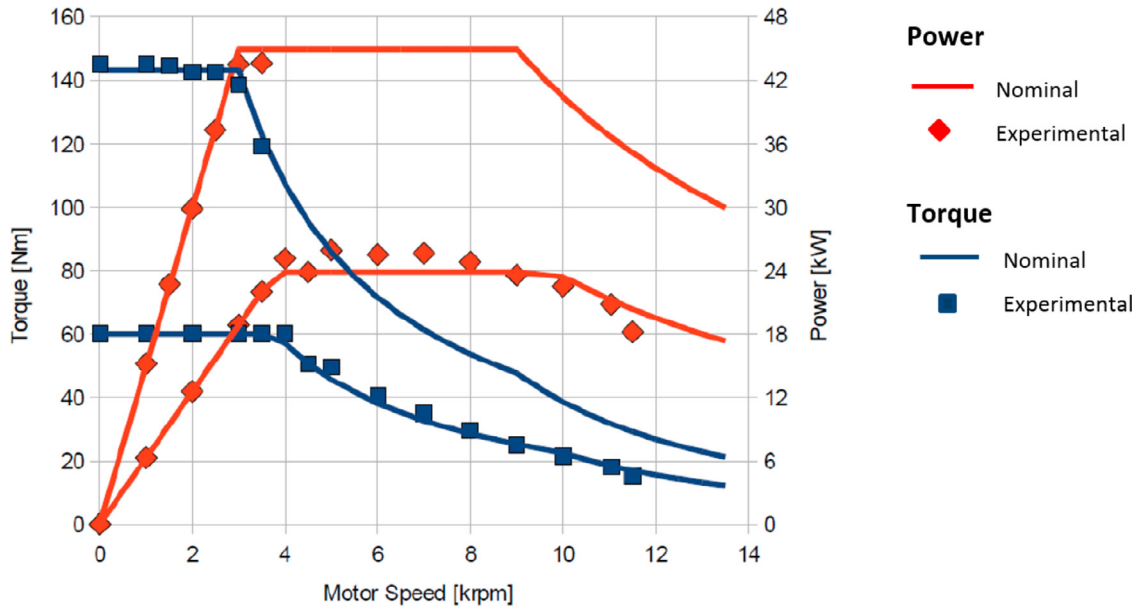

Fig. 21. [38]. IPM motor characteristic: Torque and Power curves: nominal vs. experimental .

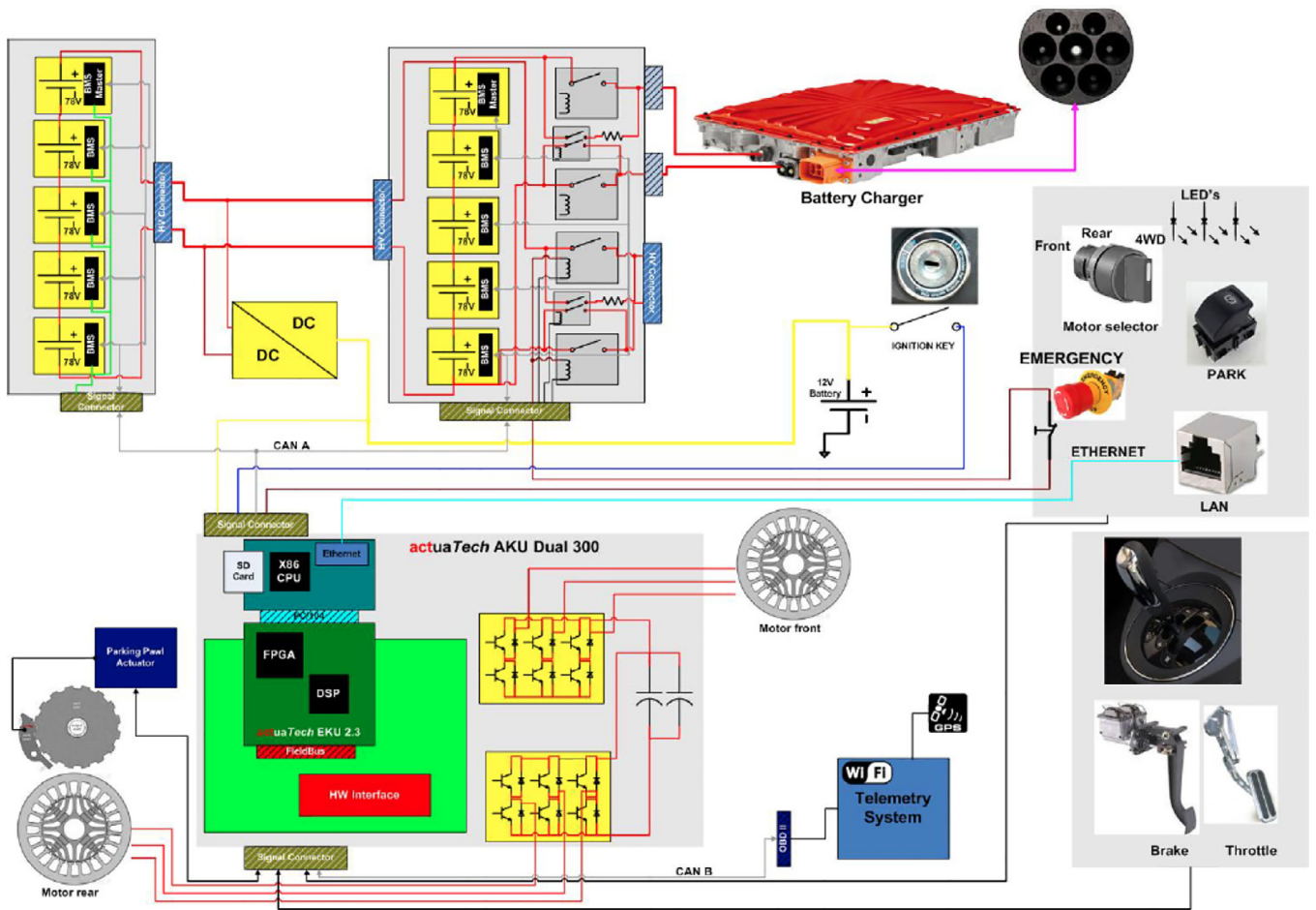

Fig. 22. Power train block scheme.



Fig. 23. Electric Delivery Van.

**Table 4**  
EDV. Calculation of the range on a WLTP cycle.

Energy consumption (without regenerative braking)	1236 Wh [151,3 Wh/km]
Energy consumption (regenerative braking: 30Nm)	988,8 Wh [121 Wh/km]
Path length	8,17 km
Available Energy (80% of Nominal Energy)	23,68 kWh
Range (without regenerative braking)	156,5 km
<b>Range (with regenerative braking)</b>	<b>195,7 km</b>

d'Orlando, Sicily, Italy). The selected paths are characterized by different slopes and different loads that have allowed for evaluation of the vehicle's performances simulating both a last mile urban distribution situations and a possible use of the vehicle in more demanding conditions through roads with a gradient of up to 18% (Table 5). The routes have as their point of departure and arrival the UDC in which it is present the charging infrastructure powered by RES that will be described in other work. A map representation is shown in the Fig. A1–A7 reported in the Appendix.

Finally, Table 6 summarizes the main technical specifications of the developed vehicle including the two additional parameters P1 and P2 introduced in Section 4. The analysis of the characteristics shows how all project constraints have been complied. In particular for urban applications relating to deliveries within the last mile (no more than 10 km), the vehicle is capable of being able to carry out different routes without having to be recharged. As far as extra-urban applications are concerned, the data collected, together with the presence of all-wheel drive and the maneuverability of the vehicle together with the load capacity, confirm the possibility of using the EDV also to reach, through roads

**Table 5**  
EDV. Test paths on the testing site.

Path	Length [km]	Maximum slope [%]	Load [kg]	Average consumption [Wh/km]	Traction	Reference application
1	14,7	2%	0	115,44	2WD - Front	Urban
2	13	2%	400	143,18	2WD - Rear	Urban
3	11	2%	800	187,43	2WD - Rear	Urban
4	11,6	12%	400	171,72	4WD	Urban / Suburban
5	16,3	12%	800	231,59	4WD	Urban / Suburban
6	34,9	16%	800	268,40	4WD	Suburban
7	4,62	18%	800	307,91	4WD	Suburban

**Table 6**  
EDV. Main technical specifications.

Classification	Loading Bed
Car seats	2
Chassis	Body on frame
Length (cm)	490
Width (cm)	200
Height (cm)	210
Load Area	300 × 180
L x W (cm) - m <sup>2</sup>	5,4
Curb vehicle weight (kg)	1070
Payload (kg)	800
Motor Power (kW)	2 × 28
Battery Energy (kWh)	29.6
Battery Chemistry	Lithium (Li-Poly)
Traction	4-wheel drive
Range (km)	195
Fast Charging Time	55 min. @ 22 kW
P1 (W/Kg)	<b>52,34</b>
P2	<b>0,43</b>

with a gradient even greater than 10%, the main municipalities of the Nebrodi area (testing site), all between 29 and 62 km from the UDC [4]. Observing the geographical area where the experimentation was carried out, a further element of interest deriving from the analysis of the data on field is the possibility of reaching the three metropolitan areas mentioned in Section 3.2 (Provinces of Messina, Catania and Palermo) without the need to recharge the vehicle on the path. This was not the primary objective of this work, which analyzed the potential of the vehicle in the context of freight delivery in the context of the last mile and in suburban applications but it contributes to reinforce the concept of versatility that guided the design of the EDV. In Fig. 23 is showed the developed EDV.

## 6. Conclusions

The technological solutions that concern the so-called sustainable logistics seem to be applied almost exclusively to urban distribution and the overall technical specifications of the electric LCVs offered by the market are not always adaptable to suburban areas.

The article, after analyzing the possible trends related to the technological change taking place in the field of sustainable logistics, showed the development phases of a new concept EDV. The vehicle, characterized by features specifically designed both for the needs of a last mile distribution in an urban area and for suburban distribution in small villages, have been described in the paper with the aim of directing the possible choices within the process of spreading zero emission vehicles.

The technical choices made for the peculiarity of the Italian territory were motivated through a case study.

The geographical context used as a reference in the case study is representative of a widespread scenario in Italy where the presence of small villages is very high. With the aim of guaranteeing high vehicle manoeuvrability and versatility, some project constraints have been introduced at a preliminary stage. Particular attention was paid to the loading surface, able to accommodate two Europallets, to the ratio between transportable weight and total weight and to the possibility of fast charging.

The choice of the cab in an advanced position and the driver placed above the front end axle allowed maximize the useful ratio between overall dimensions and load area. The use of aluminum also made it possible to reduce the overall weight of the frame, which allows to install different upper body. An ESS, with lithium polymer batteries guarantees a nominal range compared to its segment. Road tests have demonstrated the vehicle's ability to be used even for suburban applications involving roads with high slopes. Two IPM electric motors, one for the front axle and the other for the rear axle enable all-wheel drive to maintain proper grip on uneven ground. The first tests on the vehicle confirmed the respect of all the project constraints demonstrating that, through a new class of electric vehicles for freight transport, it is possible to implement sustainable logistics policies even in non-urban areas.

## Declaration of Competing Interest

None.

## Acknowledgments

Supported by National Operative Program, grants no. PON 04a2\_h.

## Appendix A

- [A1] <https://alke-elektrofahrzeuge.de/wp-content/uploads/2019/05/alke-atex-explosionsgeschutzte-fahrzeuge-de.pdf>
- [A2] <http://www.zetacar-autosogno.it/nuovo/documents/Berlingo%20Van%20-%20Electric%20Caratteristiche%20tecniche.pdf>
- [A3] <http://www.e-station-store.it/allegati/Come%20ricaricare%20il%20Citro%C3%ABn%20Berlingo%20Van%20Full%20Electric.pdf>
- [A4] <https://www-europe.nissan-cdn.net/content/dam/Nissan/ch/it/brochures/lcv/e-nv200-brochure-listinoprezzi.pdf>
- [A5] <https://media.peugeot.it/file/03/6/-07-listino-partner-info-2018-mar.392036.pdf>
- [A6] <https://media.peugeot.it/file/07/1/partner.306071.pdf>

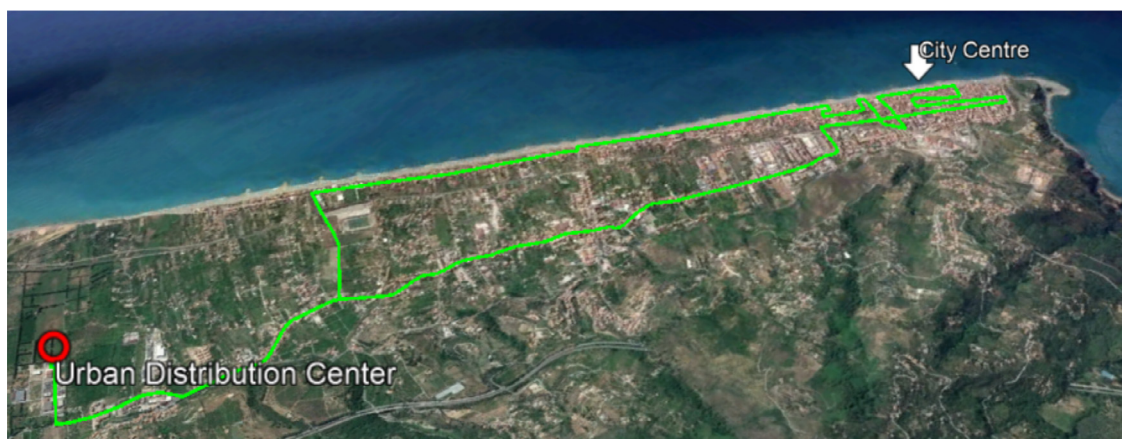

**Fig. A1.** EDV. Test path 1.



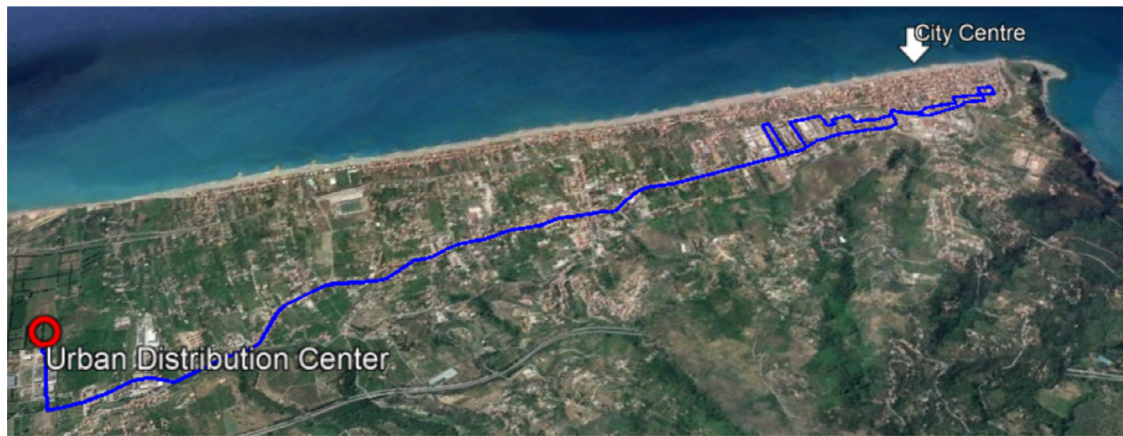

Fig. A2. EDV. Test path 2.

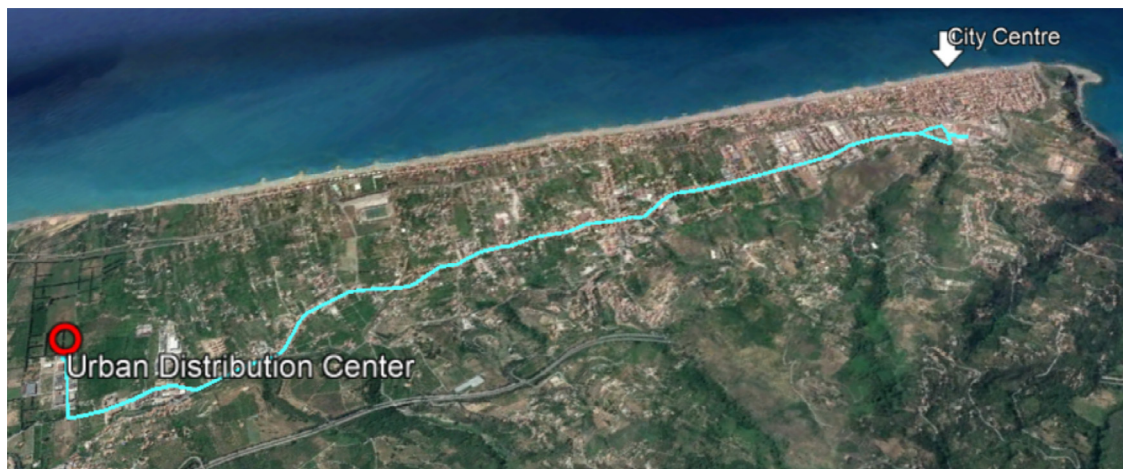

Fig. A3. EDV. Test path 3.



Fig. A4. EDV. Test path 4.

[A7] <http://www.piaggiocommercialvehicles.com/mediaObject/commercial-vehicles/master/models/porter-elettrico/LQ-IT-PorterElectric-09-2015/original/LQ-IT-PorterElectric-09-2015.pdf>

[A8] [https://www.rawlinsongroup.co.uk/newmodels/kangoo-brochure\(1\).pdf](https://www.rawlinsongroup.co.uk/newmodels/kangoo-brochure(1).pdf)

[A9] <https://www.press.renault.co.uk/assets/documents/original/17937-RE37517MasterPressKitV1.pdf>

[A10] <https://professional.renault.it/veicoli-elettrici-ibridi/masterze/dimensioni-scheda-tecnica.html>

[A11] <https://group.renault.com/en/news-on-air/news/renault-master-z-e-a-large-electric-van-an-ideal-workhorse-to-reach-city-centers-with-zero-emissions/>

- (1) max vehicle model length (version with cargo bed)
- (2) max vehicle cab width (with wing mirrors open)
- (3) vehicle height with beacon light (with standard tyres)

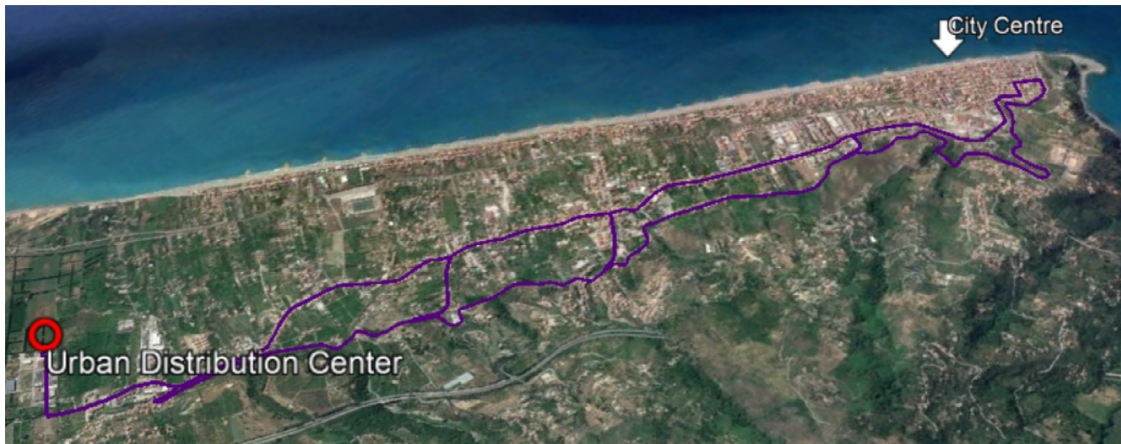

Fig. A5. EDV. Test path 5.



Fig. A6. EDV. Test path 6.

- (4) standard dropside box dimension
- (5) unloaded vehicle weight (chassis version with battery)
- (6) maximum chassis load capacity with dropside body with manual tipping (aluminum drop sides H30 cm) of 130 kg
- (7) Maximum autonomy: approximate and obtained on a flat surface,
- (8) Calculated as Battery Energy / Charging Time
- (\*) multiple rows in the same cell refers to different configuration of the same vehicle
- (9) Full Electric L1 - 2 seats
- (10) Full Electric L1 - 3 seats
- (11) Full Electric L2 - 3 seats
- (12) width mirrors included
- (13) max vehicle curb weight with driver
- (14) Full Electric L1
- (15) Full Electric L2

- (16) max vehicle curb weight with driver
- (17) Calculated as Battery Energy / Charging Time
- (\*\*) Considered only loading area for L1 and L2 models
- (18) Cab
- (19) Short flatbed
- (20) Long flatbed
- (21) Tipper body
- (22) Van
- (23) Glazed Van
- (24) Calculated as Gross vehicle weight (1800 kg) by subtracting the payload
- (25) NEW KANGOO VAN Z.E. 33
- (26) NEW Kangoo Maxi Van Z.E. 33
- (27) NEW Kangoo Maxi Crew Van Z.E. 33
- (28) NEW Kangoo Maxi Crew Van CAB Z.E. 33

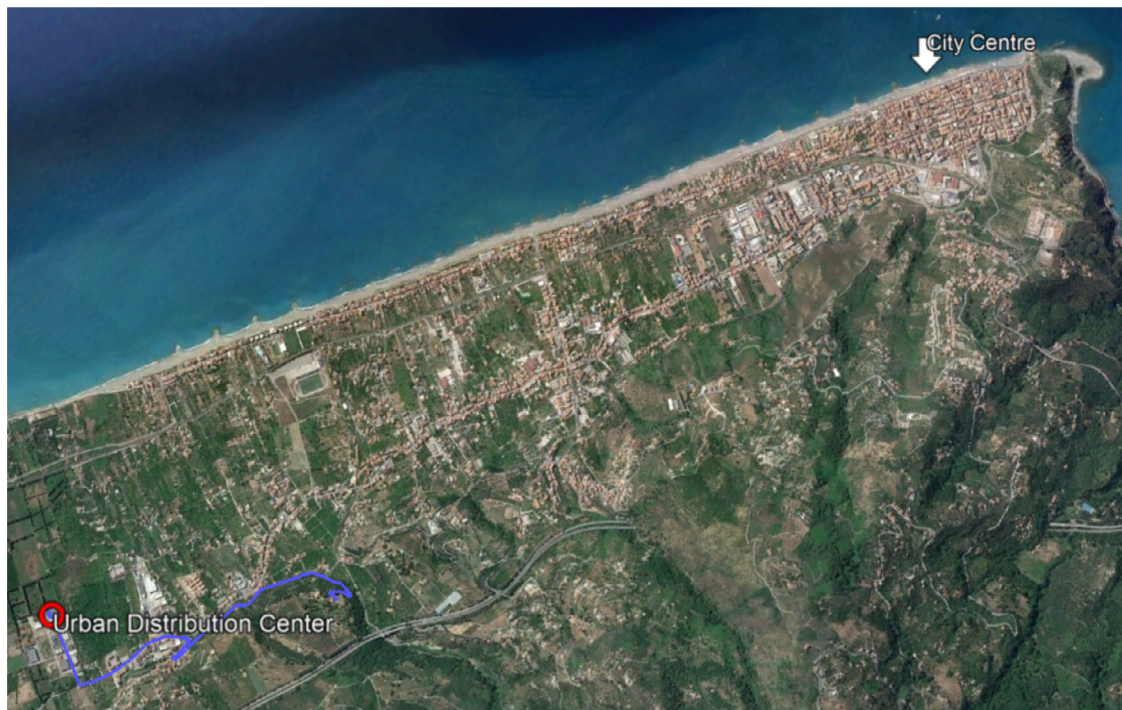

Fig. A7. EDV. Test path 7.

- (29) Overall width (without mirrors)
- (30) Unladen height
- (31) Rear width - bottom
- (32) Calculated as Battery Capacity (kWh) / Electricity Consumption (Wh/km)
- (33) L1H1 FWD SL31 i Z.E. Business
- (34) L1H2 FWD SM31 i Z.E. Business
- (35) L2H2 FWD MM31 i Z.E. Business
- (36) L3H2 FWD LM31 i Z.E. Business
- (37) vehicle cab width (with wing mirrors open)
- (38) Calculated as Gross vehicle weight (3500 kg) by subtracting the payload

Figs. A1–A7

## References

- [1] European Commission (2019) Statistical pocketbook 2019. Source: <https://ec.europa.eu/transport/facts-fundings/statistics/pocketbook-2019>
- [2] K. Rashidi, M. Stadelmann, A. Patt, Valuing co-benefits to make low-carbon investments in cities bankable: the case of waste and transportation projects, *Sustain. Cities Soc.* 34 (2017) 69–78.
- [3] L.T. Silva, J.F.G. Mendes, City noise-air: an environmental quality index for cities, *Sustain. Cities Soc.* 4 (2021) 1–11.
- [4] G. Napoli, S. Micari, G. Dispenza, S. Di Novo, V. Antonucci, L. Andaloro, Development of a fuel cell hybrid electric powertrain: a real case study on a Minibus application, *Int. J. Hydrogen Energy* 42 (46) (2021) 28034–28047.
- [5] E. Ferrero, S. Alessandrini, A. Balanzino, Impact of the electric vehicles on the air pollution from a highway, *Appl. Energy* 169 (2016) 450–459.
- [6] Civitas, Policy Note, (2015). Smart choices for cities. Making urban freight logistics more sustainable.
- [7] M. Todorovic, M. Simic, Smart innovation, systems and technologies, in: Proceedings of the 11th International KES Conference on Intelligent Interactive Multimedia: Systems and Services, KES-IIMSS 2018, 98, 2019, pp. 130–139.
- [8] European Commission, Transport in the European union current trends and issues, *Mobil. Transp.* (2018) 2018. <https://ec.europa.eu/transport/sites/transport/files/2019-transport-in-the-eu-current-trends-and-issues.pdf>.
- [9] JCR (2018). External costs of freight transport in European Union Member States. <http://data.europa.eu/88u/dataset/jrc-tem-e1>
- [10] H. Wang, J. Han, M. Su, S. Wan, Z. Zhang, The relationship between freight transport and economic development: a case study of China, *Res. Transp. Econ.* (2020) 100885 Available online in PressCorrected Proof.
- [11] H. Buldeo Rai, T. van Lier, D. Meers, C. Macharis, Improving urban freight transport sustainability: policy assessment framework and case study, *Res. Transp. Econ.* 64 (2017) 26–35.
- [12] Pelletier, S., O. Jabali and G. Laporte (2014 b), Goods distribution with electric vehicles: review and research perspectives, *CIRRELT* 2014-44.
- [13] M. Wang, K.D. Thoben, The influential factors for application of the electric commercial vehicle in the urban freight transport, *Dyn. Logist.* (2017) 375–378.
- [14] F. Russo, A. Comi, A classification of city logistics measures and connected impacts, *Procedia - Soc. Behav. Sci.* 2 (3) (2010) 6355–6365.
- [15] A. Yasin, G. Napoli, M. Ferraro, A. Testa, V. Antonucci, Fuzzy logic based management of a stand-alone hybrid generator, in: Proceedings of the Third International Conference on Clean Electrical Power: Renewable Energy Resources Impact, ICCEP, 2011, pp. 690–696. art.
- [16] G. Dispenza, F. Sergi, G. Napoli, N. Randazzo, S. Di Novo, S. Micari, V. Antonucci, L. Andaloro, Development of a solar powered hydrogen fueling station in smart cities applications, *Int. J. Hydrogen Energy* 42 (46) (2017) 27884–27893.
- [17] Figenbaum, Can battery electric light commercial vehicles work for craftsmen and service enterprises? *Energy Policy* 120 (2018) 58–72.
- [18] D. Margaritis, A. Anagnostopoulou, A. Tromaras, M. Boile, Electric commercial vehicles: practical perspectives and future research directions *Res. Transp. Bus. Manag.* 18 (2016) 4–10.
- [19] ACEA, European Automobile Manufacturers Association, New Commercial Vehicle registrations, European Union, December 2019. <https://www.acea.be/press-releases/article/commercial-vehicle-registrations-2.5-full-year-2019-5.7-in-december>
- [20] Rajalakshmi, Frost&Sullivan, Global light commercial vehicle market to be shaped by advances in electric and autonomous technology, *Autom. Transp. Frost Perspect.* (2019) <https://ww2.frost.com/frost-perspectives/global-light-commercial-vehicle-market-to-be-shaped-by-advances-in-electric-and-autonomous-technology>.
- [21] European Commission. Regulation (EU) 2019/631
- [22] C. Kailasam, Frost&Sullivan, Electrics are the future for light commercial vehicles, *Autom. Transp. Frost Perspect.* (2019) <https://ww2.frost.com/frost-perspectives/electrics-are-future-light-commercial-vehicles/>.
- [23] A. Tsakalidis, J. Krause, A. Julea, E. Peduzzi, E. Pisoni, C. Thiel, Electric light commercial vehicles: are they the sleeping giant of electromobility, *Transp. Res. Part D-Transp. Environ.* 86 (2020). <https://www.sciencedirect.com/science/article/pii/S1361920920306088?via%3Dihub>.
- [24] A.M. Moore, Innovative scenarios for modeling intra-city freight delivery, *Transp. Res. Interdiscip. Perspect.* 3 (2019). <https://www.sciencedirect.com/science/article/pii/S2590198219300247?via%3Dihub>.
- [25] The European House Ambrosetti- Enel, E-Mobility Revolution, Gli impatti sulle filiere industriali e sul sistema-Paese: quale Agenda per l'Italia (2017). [https://www.ambrosetti.eu/wp-content/uploads/ENEL\\_e-Mobility-Revolution\\_Ricerca-2017\\_ITA.pdf](https://www.ambrosetti.eu/wp-content/uploads/ENEL_e-Mobility-Revolution_Ricerca-2017_ITA.pdf).
- [26] The European House Ambrosetti- Enel, Electrify 2030, Electrification, industrial value chains and opportunities for a sustainable future in Europe and Italy (2018). [https://www.ambrosetti.eu/wp-content/uploads/Electrify-2030\\_versione-online.pdf](https://www.ambrosetti.eu/wp-content/uploads/Electrify-2030_versione-online.pdf).
- [27] ANFIA, Associazione Nazionale Filiera Industria Automobilistica. Focus Italia Veicoli commerciali e industriali. Gennaio/Dicembre 2019. Rapporto semestrale sul settore dei veicoli commerciali, autocarri, R&S e autobus. 2020.

- [https://www.anfia.it/data/portale-anfia/Ufficio\\_stampa/News\\_e\\_articoli/ITALIA-Focus\\_Veicoli\\_commerciali\\_e\\_industriali\\_Gen-Giu\\_2020.pdf](https://www.anfia.it/data/portale-anfia/Ufficio_stampa/News_e_articoli/ITALIA-Focus_Veicoli_commerciali_e_industriali_Gen-Giu_2020.pdf).
- [28] Associazione mondiale della Strada. AIPCR Comitato Nazionale Italiano. "Strade locali extraurbane e accessibilità alla viabilità maggiore". Comitato Tecnico A.4. Sviluppo e gestione della viabilità extraurbana minore e rurale in Italia: situazione attuale, criticità e prospettive
- [29] A. Nuzzolo, A. Comi, Urban freight demand forecasting: a mixed quantity/delivery/vehicle-based model, *Transp. Res. Part E: Logist. Transp. Rev.* 65 (2014) 84–98.
- [30] Volumetric Weight: DHL Express [http://www.dhl.com/en/tools/volumetric\\_weight\\_express.html](http://www.dhl.com/en/tools/volumetric_weight_express.html)
- [31] M. Einhorn, V. Conte, C. Kral, J. Fleig, Comparison, selection, and parameterization of electrical battery models for automotive applications, *IEEE Trans. Power Electron.* 28 (2013) 1429–1437.
- [32] L. Andaloro, A. Arista, G. Agnello, G. Napoli, F. Sergi, V. Antonucci, Study and design of a hybrid electric vehicle (Lithium Batteries-PEM FC), *Int. J. Hydrogen Energy* 42 (Issue 5) (2017) 3166–3184.
- [33] M.Feng M.Li, D. Luo, Z. Chen, Fast charging Li-Ion batteries for a new era of electric vehicles, *Cell Reports Phys. Sci.* 10 (1) (2020).
- [34] P. Cicconi, D. Landi, M. Germani, Thermal analysis and simulation of a Li-ion battery pack for a lightweight commercial, *EV. Appl. Energy* 192 (2017) 159–177.
- [35] IEC 62196-1. Plugs, socket-outlets, vehicle couplers and vehicle inlets – Conductive charging of electric vehicles – International Standards. [https://www.iec.ch/dyn/www/f?p=103:38:16310975637681:::FSP\\_ORG\\_ID,FSP\\_APEX\\_PAGE,FSP\\_PROJECT\\_ID:1426,23,100327](https://www.iec.ch/dyn/www/f?p=103:38:16310975637681:::FSP_ORG_ID,FSP_APEX_PAGE,FSP_PROJECT_ID:1426,23,100327).
- [36] Micari et al. (2017) S. Micari, A. Polimeni, G. Napoli, L. Andaloro, V. Antonucci, Electric vehicle charging infrastructure planning in a road network, *Renew. Sustain. Energy Rev.* 80 (2017) 98–108.
- [37] K. Lalit, J. Shailendra, Electric propulsion system for electric vehicular technology: a review, *Renew. Sustain. Energy Rev.* 29 (2014) 924–940.
- [38] L. Andaloro, G. Napoli, F. Sergi, S. Micari, G. Agnello, V. Antonucci, Development of a new concept electric vehicle for last mile transportations, *World Electr. Veh. J.* 7 (2015) 342–348.
- [39] A. Di Bella, L. Fortuna, S. Graziani, G. Napoli, M.G. Xibilia, A comparative analysis of the influence of methods for outliers detection on the performance of data driven models, in: *Proceedings of the IEEE Instrumentation and Measurement Technology Conference, 2007*, pp. 1091–5281. (ISSN).
- [40] Di Bella, Fortuna A., Graziani L., Napoli S., Xibilia G., Development of a soft sensor for a thermal cracking unit using a small experimental data set, in: *Proceedings of the IEEE International Symposium on Intelligent Signal Processing, WISP, 2007* (ISBN) 978-142440830-6.
- [41] G Napoli, et al., **Freight distribution with electric vehicles: a case study in Sicily. RES, infrastructures and vehicle routing**, *Transportation Engineering* (2021) In press.